

What filter damage may do to your business

- Filter failure – lower yields and lower product quality cause extra costs
- Damaged filter – higher emissions to the atmosphere and extra costs due to heavy fines
- Filter breakup – possible risk to the work environment and personnel



Snifter Dust Monitor

Developed and designed especially for filter leak detection



Snifter – perfect choice for filter break up detection

- Low-Cost
- Broken Bag Detection
- Self Adjusting
- No Drift

Snifter is used to detect filter bag breakage quickly and cost-effectively. It is a compact device consisting of an enclosure housing state of the art electronics and a probe.

Snifter utilises Sintrol's automatic setup function. With this function, it can adjust itself to dust flow conditions in your application. It is equipped with two alarm relays. The first alarm is activated when the dust concentration exceeds a reference level by five times and the second by 20 times. A three-colour LED provides optical information about the condition of the filter:

Led in the front panel indicates the particle concentration:

- Green = OK
- Yellow = 5 x normal
- Red = 20 x normal

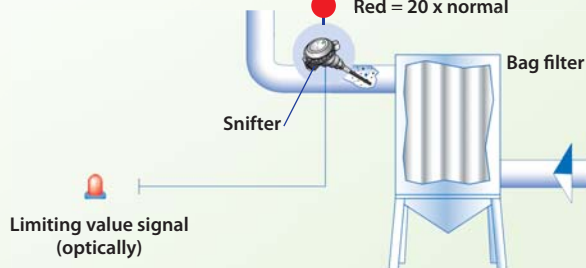

Snifter has the necessary sensitivity to meet the low levels of dust concentrations typical of modern fabric filters. It is reliable enough both in terms of operating continuously without maintenance, and in being able to run despite vibration and build-up on the probe. It is able to respond quickly enough to meet the requirements of bag filters.

The alarms can also be used for process control (as an ON-OFF system) in FLOW – NO FLOW situations in bulk solids

handling and pneumatic transport applications. Very fast response time, a typical characteristic of this instrument, enables early detection and prevention of expensive product loss to the environment. Also available in ATEX version.

Technical Specifications

Measurement objects	Solid particles in a gas flow
Particle size	0.3 µm or larger
Measurement range	from 0.1 mg/m ³
Temperature	Max. 140 °C
Pressure	200 kPa
Gas velocity	Min. 4 m/sec
Humidity	95% RH (non-condensing)
Measurement principle	Triboelectric AC signal
Damping time constant	1 – 300 s
Output signals	2 solid state relays (170 mA / 200 mA if only one output)
Ambient temperature	-20...+60 °C
Sensor rod	Stainless steel (230 mm)
Enclosure / casing	Aluminium
Protection category	IP 65
Power supply	12 – 24V DC
Power consumption	3W
Cable connection	2 meter cable - 4 pair - screened
Installation	1/2" thread
Weight	Approx. 0.7 kg

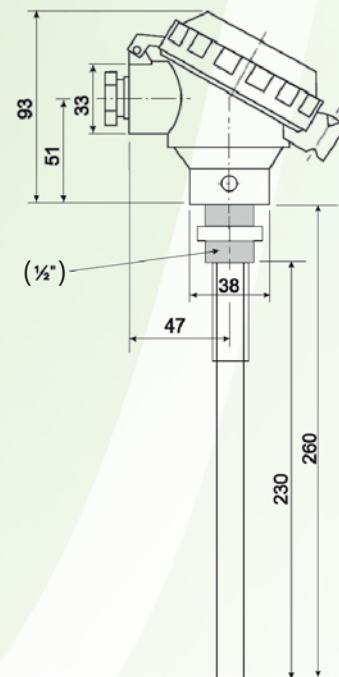

Measures mm (inch)

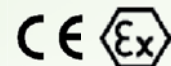

Sintrol Inc.

Sintrol is a global solutions provider for industrial measurement equipment and monitors. Our product line and expertise allow us to offer innovative and tailored solutions for our clients. With a clientele that spans all areas of heavy manufacturing in over 30 countries, we seek long term relationships with an emphasis on creating custom offerings. We are constantly developing new products to bring greater efficiency and cost savings to our clients.

Ruosilantie 15
00390 Helsinki FINLAND

P. + 358 9 5617 360
Fax + 358 9 5617 3680

www.sintrol.com
info@sintrol.com