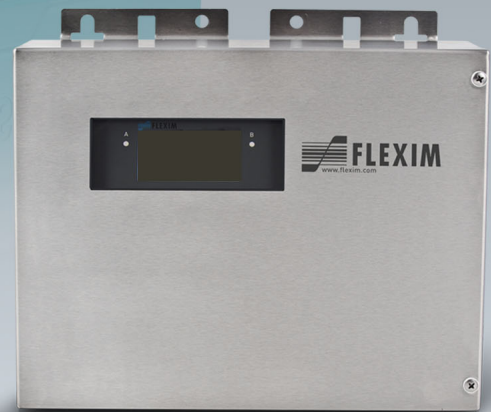
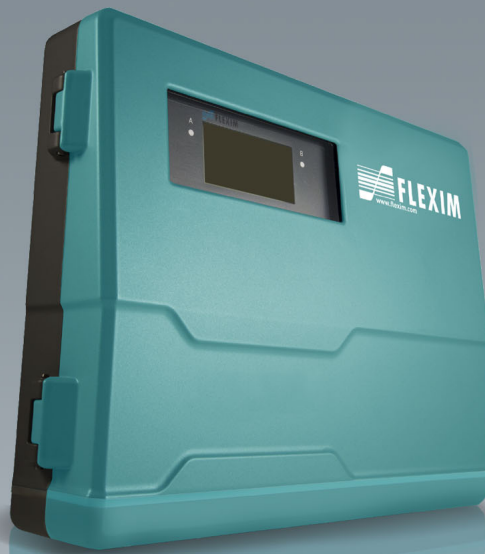


# Operating instruction

**FLUXUS F72\***



**UMFLUXUS\_F72xV2-1EN**

FLUXUS is a registered trademark of FLEXIM GmbH.

FLEXIM GmbH  
Boxberger Straße 4  
12681 Berlin  
Germany

Tel.: +49 (30) 936 67 660  
Fax: +49 (30) 936 67 680  
E-mail: [info@flexim.com](mailto:info@flexim.com)  
[www.flexim.com](http://www.flexim.com)

Operating instruction for  
FLUXUS F72\*  
UMFLUXUS\_F72xV2-1EN, 2022-05-15  
Article number: 25829  
Copyright (©) FLEXIM GmbH 2022  
Subject to change without prior notice.

## Table of contents

<b>1</b>	<b>Introduction</b>	7
<b>2</b>	<b>Safety instructions</b>	8
2.1	General safety instructions	8
2.2	Intended use	8
2.3	Not intended use	9
2.4	Safety instructions for the user	9
2.5	Safety instructions for the operator	9
2.6	Safety instructions for electrical work	9
2.7	Safety instructions for transport	10
2.8	Recommended procedure in hazardous situations	10
<b>3</b>	<b>General principles</b>	11
3.1	Measurement principle	11
3.2	Measurement arrangements	15
3.3	Acoustic penetration	17
3.4	Undisturbed flow profile	18
<b>4</b>	<b>Product description</b>	21
4.1	Measuring system	21
4.2	Handling concept	21
4.3	Display	23
4.4	Keyboard	24
<b>5</b>	<b>Transport and storage</b>	25
5.1	Transport	25
5.2	Storage	25
<b>6</b>	<b>Mounting</b>	26
6.1	Transmitter	27
6.2	Transducers	32
6.3	Temperature probe	66
<b>7</b>	<b>Connection</b>	70
7.1	Transducers	71
7.2	Power supply	83
7.3	Outputs	85
7.4	Inputs	89
7.5	Temperature probe	91
7.6	Service interfaces	95
<b>8</b>	<b>Start-up</b>	98
8.1	Start-up settings	99
8.2	Switching on	99
8.3	Status indications	100
8.4	Program branches	101
8.5	Language	101
8.6	Initialization	101
8.7	Date and time	102
8.8	Information regarding the transmitter	102

<b>9</b>	<b>Measurement</b>	103
9.1	Parameter input	103
9.2	Measurement settings	109
9.3	Start of the measurement	119
9.4	Display of measured values	122
9.5	Display of parameters	124
9.6	Repeated display of measured values	126
9.7	Execution of special functions	126
9.8	Stop of the measurement	128
<b>10</b>	<b>Troubleshooting</b>	129
10.1	Problems with the measurement	130
10.2	Measuring point selection	131
10.3	Maximum acoustic contact	131
10.4	Application-specific problems	131
10.5	Significant deviations of the measured values	132
10.6	Problems with the totalizers	132
10.7	Problems during the thermal energy rate measurement	132
<b>11</b>	<b>Maintenance and cleaning</b>	133
11.1	Maintenance	134
11.2	Cleaning	134
11.3	Calibration	134
11.4	Firmware update	134
<b>12</b>	<b>Dismounting and disposal</b>	135
12.1	Dismounting	136
12.2	Disposal	136
<b>13</b>	<b>User modes</b>	137
13.1	StandardUser mode	138
13.2	ExpertUser mode	142
13.3	SuperUser mode and SuperUser ext. mode	147
<b>14</b>	<b>Outputs (TF7-*721**_*****_*****a-*****_**; a = U, V, D)</b>	151
14.1	Configuration of a binary output	151
14.2	Activation of a binary output as pulse output	153
14.3	Activation of a frequency output as pulse output	154
<b>15</b>	<b>Outputs (TF7-*72***_*****_*****a-*****_**; a = M, P, Q)</b>	156
15.1	Configuration of a digital output as binary output	156
15.2	Configuration of a digital output as pulse output	159
15.3	Configuration of a digital output as frequency output	162
<b>16</b>	<b>Inputs</b>	163
16.1	Configuration of an input	163
16.2	Assignment of an input	167
<b>17</b>	<b>Data logger</b>	168
17.1	Configuration of the data logger	168
17.2	Deletion of the data logger	172
17.3	Information regarding the data logger	172
17.4	Print of measured values	172
17.5	Transmission settings	173



<b>18</b>	<b>Data transmission</b>	174
18.1	Service interfaces	174
18.2	Process interface	175
<b>19</b>	<b>Advanced functions</b>	176
19.1	Totalizers	176
19.2	FastFood mode	179
19.3	Calculation channels	180
19.4	Diagnosis with the help of the snap function	185
19.5	Modification of the limit for the inner pipe diameter	186
19.6	Remote functions	187
19.7	Event triggers	189
19.8	Event protocol	194
<b>20</b>	<b>Settings</b>	195
20.1	Dialogs and menus	195
20.2	Measuring modes	197
20.3	Measurement settings	198
20.4	Units of measurement	199
20.5	Material and fluid scroll list	199
20.6	Working with parameter records	200
20.7	Contrast settings	201
20.8	HotCodes	201
20.9	Key lock	202
<b>21</b>	<b>Thermal energy rate measurement (option)</b>	203
21.1	Calculation of the thermal energy rate	203
21.2	Definition of the physical quantity and the unit of measurement	204
21.3	Application and transducer positioning	204
21.4	Assignment of the temperature inputs	205
21.5	Two independent thermal energy rate measurements	205

## Annex

<b>A</b>	<b>Menu structure</b>	207
<b>B</b>	<b>Units of measurement</b>	226
<b>C</b>	<b>Reference</b>	230
<b>D</b>	<b>Conformity declarations</b>	235






## 1 Introduction

This operating instruction has been written for users operating the ultrasonic flowmeter FLUXUS. It contains important information about the measuring equipment, how to handle it correctly, and how to avoid damages. Read the safety instructions carefully. Make sure you have read and understood this operating instruction before using the measuring equipment.

Any work on the measuring equipment has to be carried out by authorized and qualified personnel in order to detect and avoid possible risks and dangers.

### Presentation of warnings

This operating instruction contains warnings marked as follows:

<b>Danger!</b>	
	<b>Type and source of danger</b> danger with high level of risk, which, if not avoided, can lead to death or serious injuries → measures of prevention
<b>Warning!</b>	
	<b>Type and source of danger</b> danger with medium level of risk, which, if not avoided, can lead to serious or moderate injuries → measures of prevention
<b>Caution!</b>	
	<b>Type and source of danger</b> danger with low level of risk, which, if not avoided, can lead to moderate or minor injuries → measures of prevention
<b>Important!</b>	
This text contains important information which should be observed in order to avoid material damage.	
<b>Notice!</b>	
This text contains important information about the handling of the measuring equipment.	

### Storage of the operating instruction

The operating instruction must permanently be available at the place where the measuring equipment is used. It must be available to the user at all times.

### User comments

All reasonable effort has been made to ensure the correctness of the content of this operating instruction. If you, however, find some erroneous information or miss information, please inform us.

We will be grateful for any suggestions and comments regarding the concept and your experience when working with the measuring equipment. If you have any suggestions about improving the documentation and particularly this operating instruction, please let us know so that we can consider your comments for future reprints.

### Copyright

The contents of this operating instruction are subject to changes without prior notice. All rights reserved. No part of this operating instruction may be reproduced in any form without FLEXIM's written permission.

## 2 Safety instructions








### 2.1 General safety instructions

Prior to any work, read the operating instruction carefully and in full.

Failure to comply with the instructions, in particular with the safety instructions, poses a risk to health and can lead to material damages. For further information, contact FLEXIM.

During installation and operation of the measuring equipment, observe the ambient and installation conditions specified in the documentation.

Explanation of symbols on the transmitter and accessories:

symbol	explanation
	direct current
	connection for equipotential bonding/grounding
	protective ground terminal
	Electric devices must be disposed of separately. If necessary, additional hazardous substances are indicated for disposal.
	Warning! Electric shock possible.
	Observe the operating instruction.
	Warning! Observe the safety instructions in the manufacturer's documentation.

The measuring equipment has to be checked for proper condition and operational safety before each use. If troubles or damages have occurred during installation or operation of the measuring equipment, please inform FLEXIM.

It is not allowed to make unauthorized modifications or alterations to the measuring equipment.

If the measuring point is within an explosive atmosphere, the danger zone and present explosive atmosphere have to be determined. The transmitter, transducers and accessories have to be appropriate and approved for the conditions within the corresponding zone.

Personnel has to be suitably trained and experienced for the work.

Observe the "Safety instructions for the use in explosive atmospheres" (see document SIFLUXUS). Observe the instructions for hazardous substances and the respective safety data sheets. Observe the regulations for the disposal of electrical equipment.

### 2.2 Intended use

The measuring equipment is intended for the measurement of fluid properties in closed pipes. By means of connected transducers, the transit times of the ultrasonic signals in the fluid and the pipe as well as other related properties, such as temperature and pressure, are measured and evaluated.

The transmitter uses these values to calculate the sought quantities, e.g., volumetric flow rate, mass flow rate and thermal energy. Through comparison with the values stored in the transmitter further physical quantities can be determined. The physical quantities are provided via configurable outputs and the display.

- All instructions of this operating instruction have to be observed to ensure intended use.
- Any use beyond or other than the intended use is not covered by warranty and can present a danger. Any damage arising from not intended use shall be solely the liability of the operator or user.
- The measurement is carried out without direct contact to the fluid in the pipe. The flow profile is not influenced.
- The transducers are fixed to the pipe using the supplied transducer mounting fixture.

- If an extension cable is required to connect the transducers to the transmitter, a junction box can be used (optional). Observe the safety instructions in the operating instruction. For the technical data of the junction box, see technical specification.
- Observe the operating conditions, e.g., environment, voltage ranges. For the technical data of the transmitter, transducers and accessories, see technical specification.

### 2.3 Not intended use

Not intended use in terms of a misuse means:

- any work on the measuring equipment without observing all instructions in this operating instruction
- use of transmitter, transducer and accessory combinations not intended by FLEXIM
- installation of the transmitter, transducers and accessories in explosive atmospheres they are not approved for
- any work on the measuring equipment (e.g., installation, dismantling, connection, start-up, operation, service and maintenance) carried out by unauthorized and untrained personnel
- storage, installation and operation of the measuring equipment outside the specified ambient conditions (see technical specification)

### 2.4 Safety instructions for the user

Any work on the transmitter has to be carried out by authorized and qualified personnel only. Observe the safety instructions in the operating instruction. For the technical data of transmitter, transducers and accessories, see technical specification.

- Observe the safety and accident prevention regulations applicable on the site of operation.
- Only use the supplied mounting fixtures and transducers as well as the intended accessories.
- Always wear the required personal protective equipment.

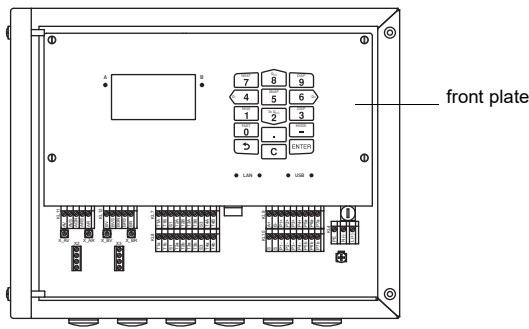
### 2.5 Safety instructions for the operator

- The operator shall qualify the personnel to perform their assigned tasks. The operator shall provide the required personal protective equipment and oblige the personnel to wear it. It is recommended to risk assess the workplace.
- Besides the safety instructions in this operating instruction, the health, safety and environment regulations applicable for the range of application of the transmitter, transducers and accessories have to be observed.
- With the exceptions stated in chapter 11, the measuring equipment is maintenance-free. Any components and spare parts may only be replaced by FLEXIM. The operator shall carry out periodic checks for changes or damages that can present a danger. For further information, contact FLEXIM.
- Observe the specifications for the installation and connection of the transmitter, transducers and accessories.

### 2.6 Safety instructions for electrical work

- Prior to any work on the transmitter (e.g., installation, dismantling, connection, service and maintenance), the transmitter has to be disconnected from the power supply. It is not sufficient to remove the internal fuse of the instrument.
- Electrical work may only be carried out if there is enough space.
- Open the transmitter in safe ambient conditions only (e.g., air humidity < 90 %, no conductive pollution, no explosive atmosphere). Otherwise, additional protective measures have to be taken.
- The degree of protection of the transmitter is only ensured if all cables are tightly fitted using cable glands and the housing is firmly screwed.
- The condition and tight fit of the electrical connections have to be checked at regular intervals.
- When connecting the transmitter to the power supply, an appropriate equipment switch according to IEC 60947-1 and IEC 60947-3 has to be installed as disconnecting device. The equipment switch has to disconnect all live wires. The ground conductor connection must not be interrupted. The equipment switch has to be easily accessible and clearly marked as a disconnecting device for the transmitter. It should be located near the transmitter. If the transmitter is used in an explosive atmosphere, the equipment switch has to be installed outside the explosive atmosphere. If this is not possible, it has to be installed in the least hazardous area.
- The connection may only be made to networks up to overvoltage category II. When connecting the inputs and outputs as well as the power supply, observe the installation instructions, in particular the terminal assignment.
- The front plate must not be removed. The transmitter does not contain any components to be maintained by the user. For repair and service work, please contact FLEXIM.
- Observe the safety and accident prevention regulations for electrical systems and equipment.

Fig. 2.1: Transmitter



## 2.7 Safety instructions for transport

### Caution!



#### Warning of injuries due to falling objects

- Unsecured and falling objects can lead to severe injuries.
- Secure all components against falling during transport.
  - Wear the required personal protective equipment.
  - Observe the applicable rules.

- If you detect a transport damage when unpacking the delivery, please contact the supplier or FLEXIM immediately.
- The transmitter is a sensitive electronic measuring instrument. Avoid shocks or impacts.
- Handle the transducer cable with care. Avoid excessive bending or buckling. Observe the ambient conditions.
- Select a solid surface to put the transmitter, transducers and accessories on.
- The transmitter, transducers and accessories have to be properly packed for transport:
  - Use, if possible, the original packaging by FLEXIM or an equivalent cardboard box.
  - Position the transmitter, transducers and accessories in the middle of the cardboard box.
  - Fill any voids with appropriate packaging material (e.g., paper, foam, bubble wrap).
  - Protect the cardboard box against humidity.

## 2.8 Recommended procedure in hazardous situations

### Fire fighting measures

- If possible, disconnect the transmitter from the power supply.
- Prior to extinguishing, protect any electrical parts that are not affected by the fire (e.g., using a cover).
- Select a suitable extinguishing agent. Avoid, if possible, conductive extinguishing agents.
- Observe the applicable minimum distances. The minimum distances differ depending on the used extinguishing agent.

## 3 General principles

In the ultrasonic flow measurement, the flow velocity of the fluid in a pipe is determined. Further physical quantities are derived from the flow velocity and from additional physical quantities, if necessary.

### 3.1 Measurement principle

The flow velocity of the fluid is measured in the TransitTime mode using the ultrasonic-transit time difference correlation principle. When measuring with a high proportion of gas or solid particles, the transmitter can toggle into the NoiseTrek mode.

#### 3.1.1 Terms

##### Flow profile

Distribution of flow velocities over the cross-sectional pipe area. For an optimal measurement, the flow profile has to be fully developed and axisymmetrical. The shape of the flow profile depends on whether the flow is laminar or turbulent and is influenced by the conditions at the inlet of the measuring point.

##### Reynolds number $Re$

Coefficient describing the turbulence behavior of a fluid in the pipe. The Reynolds number  $Re$  is calculated from the flow velocity, the kinematic viscosity of the fluid and the inner pipe diameter.

If the Reynolds number exceeds a critical value (usually approx. 2300, if the fluid flows in a pipe), a transition from a laminar flow to a turbulent flow takes place.

##### Laminar flow

A flow without any turbulence. There is no mixing between the parallel flowing layers of the fluid.

##### Turbulent flow

A flow with turbulences (swirling of the fluid). In technical applications, the flow in the pipe is mostly turbulent.

##### Transition range

The flow is partly laminar and partly turbulent.

##### Sound speed $c$

Speed of the propagating sound. The sound speed depends on the mechanical properties of the fluid or the pipe material. In pipe materials and other solid materials, a distinction is made between the longitudinal and transversal sound speed.

##### Flow velocity $v$

Average value of all flow velocities of the fluid over the cross-sectional pipe area.

##### Acoustic calibration factor $k_a$

$$k_a = \frac{c_\alpha}{\sin \alpha}$$

The acoustic calibration factor  $k_a$  is a transducer parameter which results from the sound speed  $c$  within the transducer and the angle of incidence. According to Snell's law of refraction, the angle of propagation in the adjoining fluid or pipe material is:

$$k_a = \frac{c_\alpha}{\sin \alpha} = \frac{c_\beta}{\sin \beta} = \frac{c_\gamma}{\sin \gamma}$$

##### Fluid mechanics calibration factor $k_{Re}$

With the fluid mechanics calibration factor  $k_{Re}$ , the measured value of the flow velocity in the area of the sound beam is converted into the value of the flow velocity across the whole cross-sectional pipe area. In case of a fully developed flow profile, the fluid mechanics calibration factor only depends on the Reynolds number and the roughness of the inner pipe wall. The fluid mechanics calibration factor is recalculated by the transmitter for each new measurement.

##### Volumetric flow rate $\dot{V}$

$$\dot{V} = v \cdot A$$

The volume of the fluid that passes through the pipe per unit time. The volumetric flow rate is calculated from the product of the flow velocity  $v$  and the cross-sectional pipe area  $A$ .

**Mass flow rate  $\dot{m}$**

$$\dot{m} = \dot{V} \cdot \rho$$

The mass of the fluid that passes through the pipe per unit time. The mass flow rate is calculated from the product of the volumetric flow rate  $\dot{V}$  and the density  $\rho$ .

**Thermal energy rate  $\Phi$**

The thermal energy that is transported per unit time.

**3.1.2 Measurement of the flow velocity in the TransitTime mode**

The signals are emitted and received by two transducers alternatively in and against the flow direction. If the fluid is flowing, the signals propagating in the fluid are displaced with the flow.

Caused by this displacement, the sound path of the signal is reduced in flow direction and increased in the opposite direction.

This causes a change in the transit times. The transit time of the signal in flow direction is shorter than the transit time against the flow direction. The transit time difference is proportional to the average flow velocity.

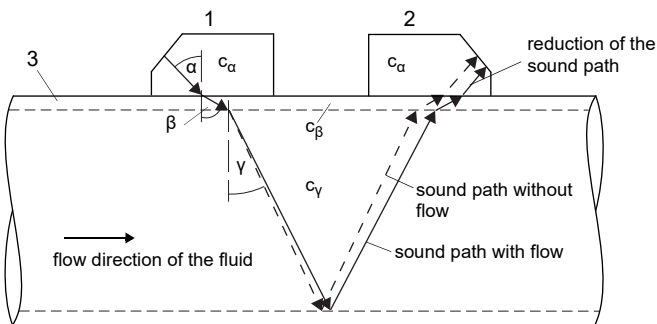
The average flow velocity of the fluid is calculated as follows:

$$v = k_{Re} \cdot k_a \cdot \frac{\Delta t}{2 \cdot t_y}$$

where

- $v$  – average flow velocity of the fluid
- $k_{Re}$  – fluid mechanic calibration factor
- $k_a$  – acoustic calibration factor
- $\Delta t$  – transit time difference
- $t_y$  – transit time in the fluid

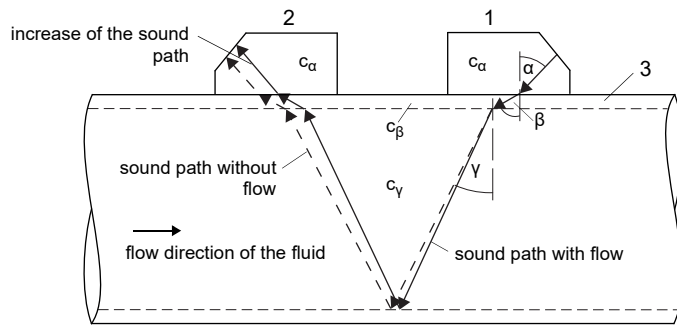
Fig. 3.1: Sound path of the signal in the flow direction



- $c$  – sound speed
- 1 – transducer (emitter)
- 2 – transducer (receiver)
- 3 – pipe wall

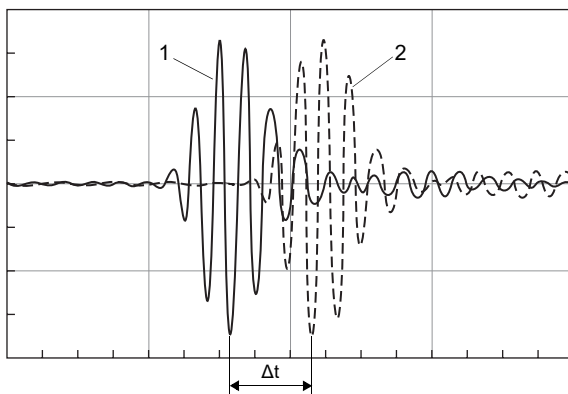


Fig. 3.2: Sound path of the signal against the flow direction



- c – sound speed
- 1 – transducer (emitter)
- 2 – transducer (receiver)
- 3 – pipe wall

Fig. 3.3: Transit time difference  $\Delta t$



- 1 – signal in the flow direction
- 2 – signal against the flow direction

### 3.1.3 Measurement of the flow velocity in the NoiseTrek mode

If the proportion of gas bubbles and/or solid particles in the fluid is high, the damping of the ultrasonic signal can be so high that the complete propagation of the fluid and therefore a measurement in TransitTime mode is not possible. In this case the NoiseTrek mode has to be used.

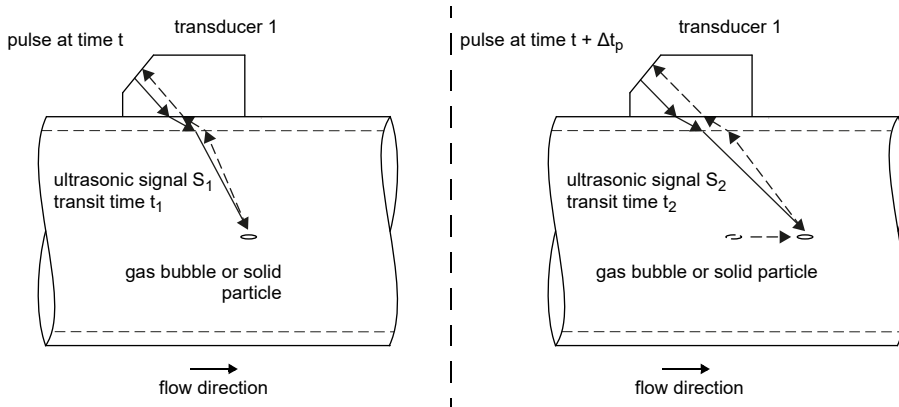
The NoiseTrek mode uses the presence of gas bubbles and/or solid particles in the fluid.

Ultrasonic signals are sent by a transducer into the fluid at short intervals, reflected by gas bubbles and/or solid particles and received again by the same transducer.

The measurement arrangement used in the TransitTime mode does not need to be changed.

The transit time difference  $\Delta t$  of 2 consecutive ultrasonic signals is determined. It is proportional to the distance the gas bubble/solid particle is covering between 2 consecutive pulses and thus to the average flow velocity of the fluid.

Fig. 3.4: Measurement of the flow velocity in the NoiseTrek mode



The average flow velocity of the fluid is calculated as follows:

$$v = k_{Re} \cdot k_a \cdot \frac{\Delta t}{2 \cdot \Delta t_p}$$

where

- v – average flow velocity of the fluid
- $k_{Re}$  – fluid mechanic calibration factor
- $k_a$  – acoustic calibration factor
- $\Delta t_p$  – time difference between 2 consecutive pulses
- $\Delta t$  – transit time difference of ultrasonic signals  $S_1$  and  $S_2$  ( $\Delta t = t_2 - t_1$ )

Depending on the attenuation of the ultrasonic signal, the measurement error in the NoiseTrek mode can be greater than in the TransitTime mode.

### 3.1.4 Measurement of the flow velocity in the HybridTrek mode

The HybridTrek mode combines the TransitTime and the NoiseTrek mode. During a measurement in the HybridTrek mode, the transmitter automatically toggles between the TransitTime and the NoiseTrek mode depending on the proportion of gas bubbles and solid particles in the fluid.

The measurement arrangement is identical to the one in the TransitTime mode.

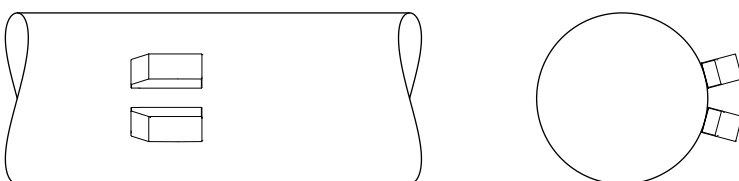
### 3.1.5 Measurement of the flow velocity in the NoiseTrek parallel beam mode

Pipes with a small diameter or fluids which strongly attenuate the ultrasonic signal can cause a reduction of the transit time in the fluid with the result that the signal quality is no longer sufficient. In this case the NoiseTrek parallel beam mode has to be used.

The NoiseTrek parallel beam mode works the same way the NoiseTrek mode does, the only difference is that the sending and receiving process do not occur in the same transducer. This leads to a better signal quality. The transducers are mounted in parallel at a small distance from each other on the pipe.

A measurement in TransitTime mode is not possible when using this measurement arrangement.

Fig. 3.5: Measurement arrangement in the NoiseTrek parallel beam mode



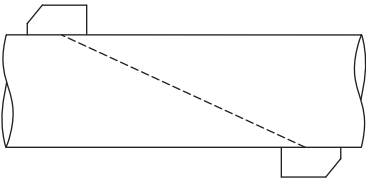
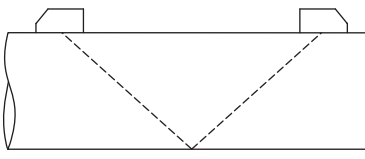
### 3.1.6 Synchronized channel averaging (FLUXUS \*722)

Synchronized channel averaging reduces turbulence-related fluctuations of the measured value without the need of long-term averaging. When measuring in reflection arrangement, X arrangement or displaced X arrangement with synchronized channel averaging, the almost simultaneous measurement of all measuring beams results in optimized compensation of turbulent flow fluctuations.

Synchronized channel averaging can only be used if the transducer pairs are of the same type and installed at the same measuring point.

## 3.2 Measurement arrangements

### 3.2.1 Terms

diagonal arrangement	reflection arrangement
The transducers are mounted on opposite sides of the pipe.	The transducers are mounted on the same side of the pipe.
	

#### Sound path

The distance covered by the ultrasonic signal after crossing the pipe once. The number of the sound paths is:

- odd if the measurement is carried out in diagonal arrangement
- even if the measurement is carried out in reflection arrangement

#### Beam

The path covered by the ultrasonic signal between the transducers, i.e., the transducer emitting the ultrasonic signal and the transducer receiving it. One beam consists of 1 or several sound paths.

Fig. 3.6: Diagonal arrangement with 2 beams and 3 sound paths

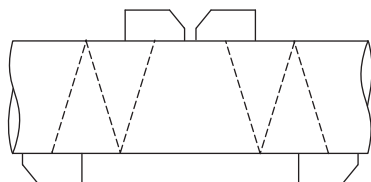
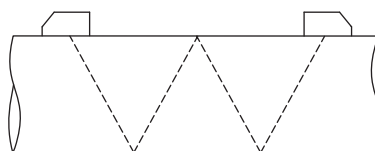
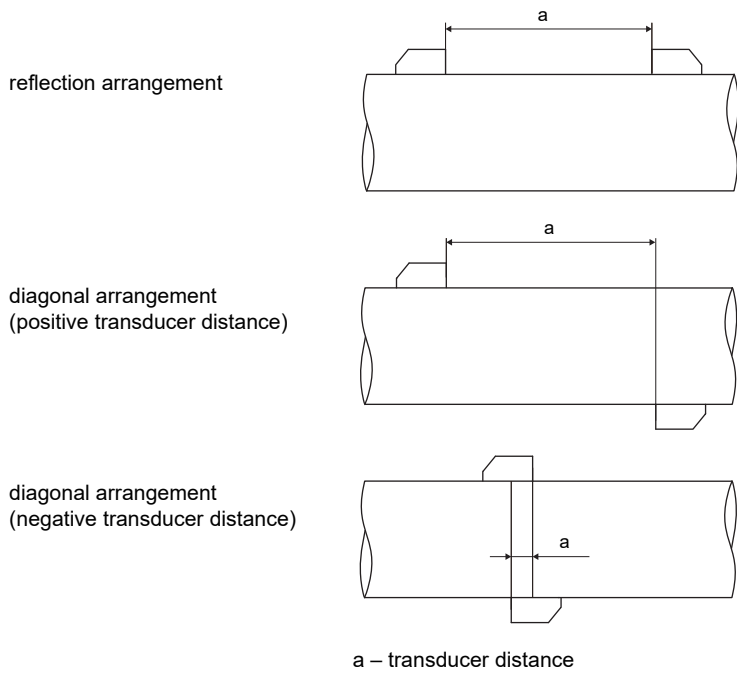


Fig. 3.7: Reflection arrangement with 1 beam and 4 sound paths



### Transducer distance

The transducer distance is measured between the inner edges of the transducers.



### Sound beam plane

Plane containing 1 or several sound paths or beams

Fig. 3.8: 2 beams in 1 plane

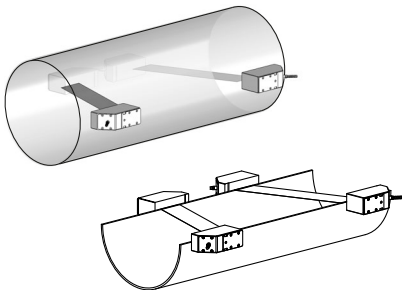
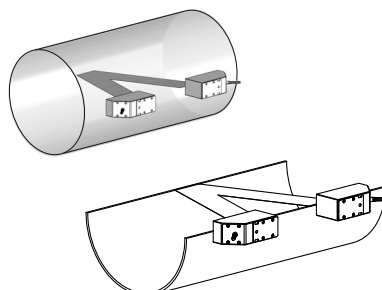
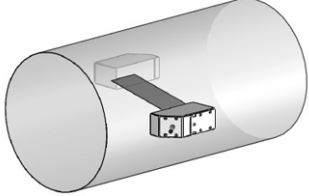
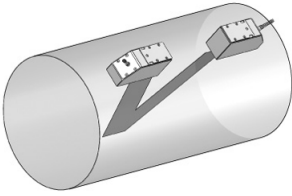
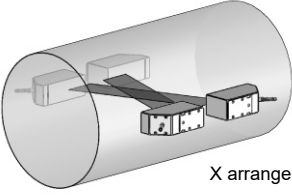
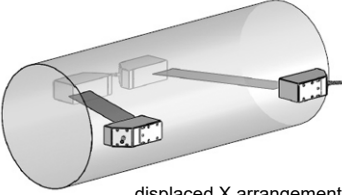
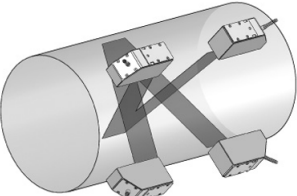


Fig. 3.9: 2 sound paths in 1 plane



### 3.2.2 Examples

diagonal arrangement with 1 beam	reflection arrangement with 1 beam
<p>1 transducer pair 1 sound path 1 beam 1 plane</p> 	<p>1 transducer pair 2 sound paths 1 beam 1 plane</p> 
diagonal arrangement with 2 beams	reflection arrangement with 2 beams and 2 planes
<p>2 transducer pairs 2 sound paths 2 beams 1 plane</p>  <p style="text-align: center;">X arrangement</p>  <p style="text-align: center;">displaced X arrangement</p>	<p>2 transducer pairs 4 sound paths 2 beams 2 planes</p> 

### 3.3 Acoustic penetration

The pipe has to be acoustically penetrable at the measuring point. The acoustic penetration is given when pipe and fluid do not attenuate the sound signal so strongly that it is completely absorbed before reaching the second transducer.

The attenuation caused by the pipe and the fluid depends on:

- kinematic viscosity of the fluid
- proportion of gas bubbles and solid particles in the fluid
- deposits on the inner pipe wall
- pipe material

The following requirements have to be met at the measuring point:

- pipe always completely filled
- no deposits of solid particles in the pipe
- no formation of gas bubbles

#### Notice!

Even bubble-free fluids can form gas bubbles when the fluid expands, e.g., before pumps and after great cross-section extensions.

Observe the following notes on the selection of the measuring point:

**Horizontal pipe**

Select a measuring point where the transducers can be mounted laterally on the pipe, allowing the sound waves to propagate horizontally in the pipe. Thus, solid particles on the bottom of the pipe or gas bubbles in the upper part are prevented from influencing the propagation of the signal.

Fig. 3.10: Recommended transducer mounting position (laterally)

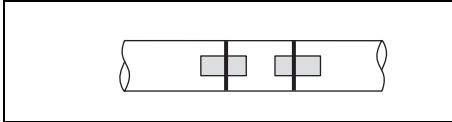
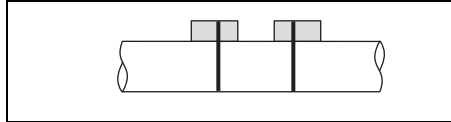


Fig. 3.11: Disadvantageous transducer mounting position (on top)



**Vertical pipe**

Select the measuring point at a pipe section where the fluid flows upward. The pipe has to be completely filled.

Fig. 3.12: Recommended transducer mounting position

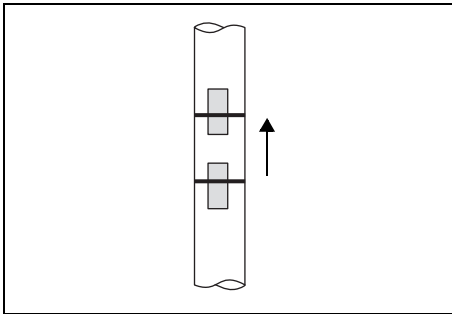
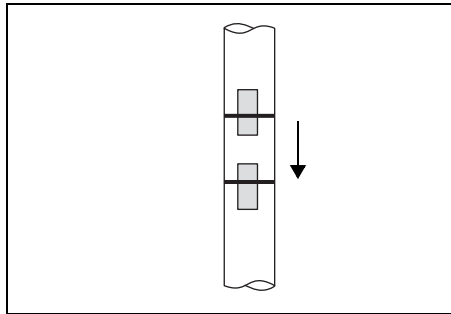


Fig. 3.13: Disadvantageous transducer mounting position



**Free inlet or outlet pipe section**

Select the measuring point at a pipe section where the pipe cannot run empty.

Fig. 3.14: Recommended transducer mounting position

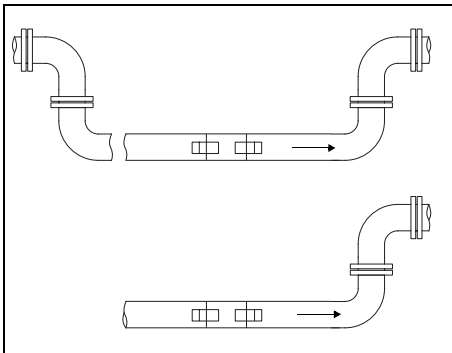
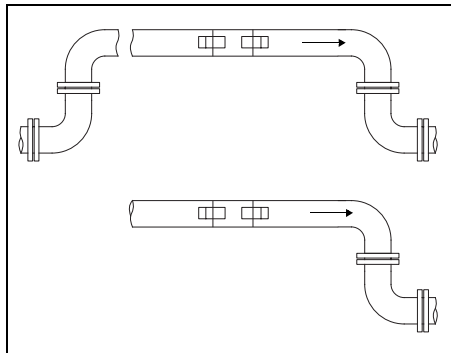


Fig. 3.15: Disadvantageous transducer mounting position



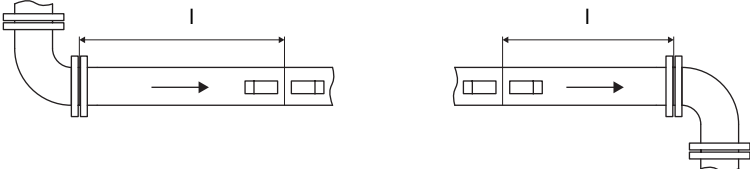
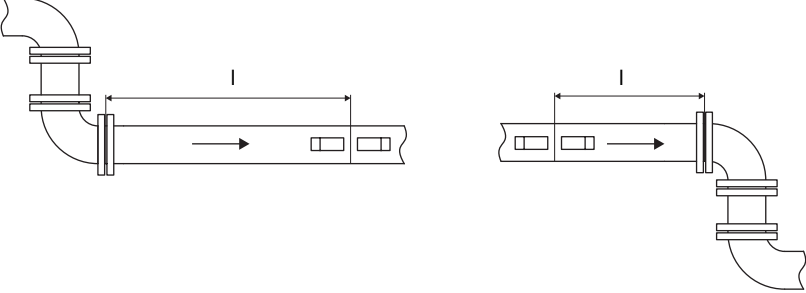
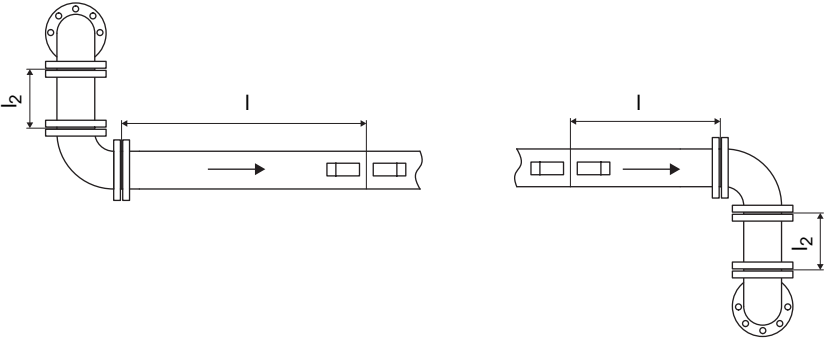
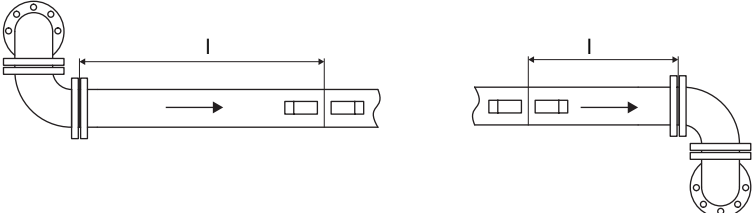
**3.4 Undisturbed flow profile**

Some flow elements (e.g., elbows, valves, pumps, reducers) distort the flow profile in their vicinity. The axisymmetrical flow profile in the pipe needed for correct measurement is no longer given. A careful selection of the measuring point helps to reduce the impact of disturbances.

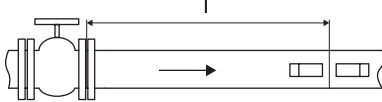
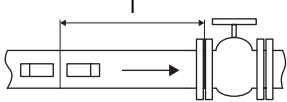
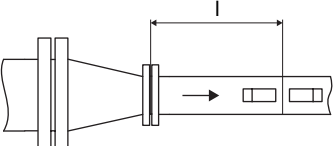
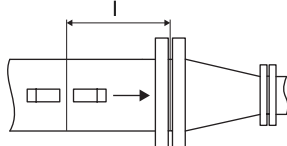
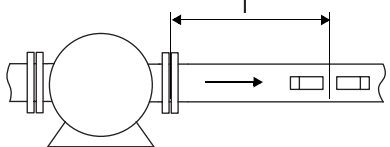
It is most important that the measuring point is chosen at a sufficient distance from any disturbances. Only then it can be assumed that the flow profile in the pipe is fully developed. The use of the disturbance correction (see section 13.2.4) allows a measurement even at smaller distances of min. 2 D.

The recommended straight inlet and outlet pipe lengths for different types of flow disturbances are shown in the following table.

Tab. 3.1: Recommended distance from disturbances  
 D – nominal pipe diameter at the measuring point  
 l – recommended distance between disturbance and transducer position

<p>disturbance: 90° elbow</p> <p>inlet: <math>l \geq 10 D</math> (<math>l \geq 2 D</math> with disturbance correction)</p> <p>outlet: <math>l \geq 3 D</math></p> 
<p>disturbance: double elbow</p> <p>inlet: <math>l \geq 10 D</math> (<math>l \geq 2 D</math> with disturbance correction)</p> <p>outlet: <math>l \geq 3 D</math></p> 
<p>disturbance: double elbow out of plane (with elbow distance <math>l_2 \geq 3 D</math>)</p> <p>inlet: <math>l \geq 10 D</math> (<math>l \geq 2 D</math> with disturbance correction)</p> <p>outlet: <math>l \geq 3 D</math></p> 
<p>disturbance: double elbow out of plane (directly coupled)</p> <p>inlet: <math>l \geq 40 D</math> (<math>l \geq 2 D</math> with disturbance correction)</p> <p>outlet: <math>l \geq 3 D</math></p> 

Tab. 3.1: Recommended distance from disturbances  
D – nominal pipe diameter at the measuring point  
l – recommended distance between disturbance and transducer position

disturbance: valve	
inlet: $l \geq 40 D$	outlet: $l \geq 5 D$
	
disturbance: reducer	
inlet: $l \geq 10 D$	outlet: $l \geq 3 D$
	
disturbance: pump	
inlet: $l \geq 20 D$	
	

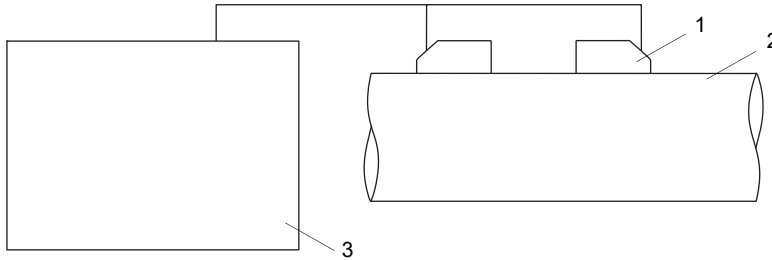


## 4 Product description

### 4.1 Measuring system

The measurement system consists of the transmitter, the ultrasonic transducers and the pipe on which the measurement is carried out.

Fig. 4.1: Example of a measurement arrangement



- 1 – transducer
- 2 – pipe
- 3 – transmitter

The transducers are mounted on the outside of the pipe. They send and receive ultrasonic signals through the fluid.

The transmitter controls the measuring cycle, eliminates noise signals and analyzes useful signals. The measured values can be displayed, used for calculations and transmitted.

### 4.2 Handling concept

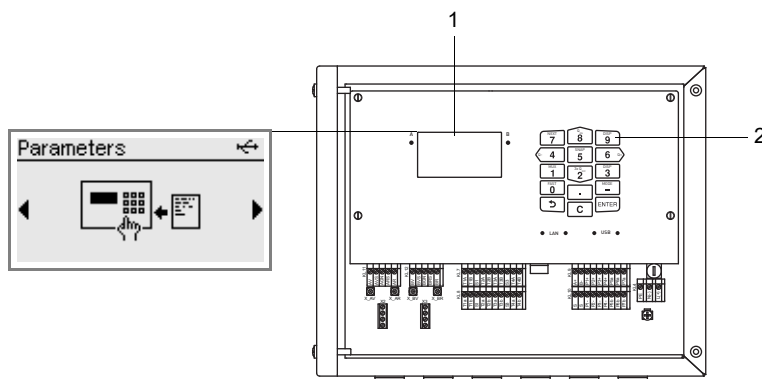
The transmitter is operated via the keyboard.

By pressing **4** or **6** the following program branches are displayed consecutively:

- Parameters
- Measurement
- Options
- Special functions

The program branch is displayed between 2 arrows (◀▶).

Fig. 4.2: Command panel of the transmitter



- 1 – LCD display (backlit)
- 2 – keyboard

Tab. 4.1: Description of the program branches

program branch	description
Parameters	Before starting a measurement, the transducer, pipe and fluid parameters have to be entered in the program branch <i>Parameters</i> .
Measurement	After activating the measuring channels and the input of the transducer distance, the measurement is started in the program branch <i>Measurement</i> .
Options	Channel-related settings are carried out in the program branch <i>Options</i> as e.g., selection of the physical quantity, selection of the unit of measurement, input of the damping factor, assignation of the inputs.
Special functions	Global settings, relating the transmitter and all measuring channels, are carried out in the program branch <i>Special functions</i> , as e.g. system settings (language, key lock), measuring settings, communication, data logger, snaps, configuration of inputs.

When starting up the transmitter for the first time, settings relating to the language, time, date and system of units have to be made. Then the program branch *Parameters* will be displayed.

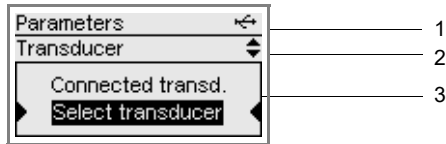
At later start-ups the measured values will be displayed in case the measurement had not been stopped before the transmitter was disconnected from the power supply. If the measurement had been stopped, the program branch *Parameters* will be displayed.

After starting the measurement, the parameter settings or the configuration of the transmitter outputs can be displayed at any time without interrupting the measurement. A change of the parameter settings is not possible during the measurement. The measurement has to be stopped in order to change the parameter settings or configuration of the transmitter outputs.

### 4.3 Display

#### Structure

Fig. 4.3: Menu item of the program branch Parameters



- 1 – program branch
- 2 – menu item currently edited
- 3 – area for scroll lists, selection fields or input fields

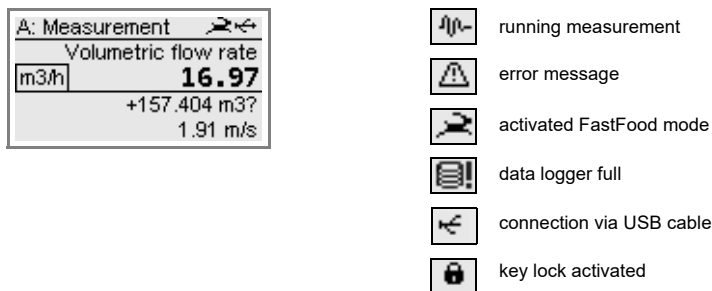
Tab. 4.2: Navigation

horizontal scroll list	vertical scroll list	selection fields	input fields
<ul style="list-style-type: none"> <li>• scroll horizontally with  4 or  6</li> </ul>	<ul style="list-style-type: none"> <li>• scroll vertically with  8 or  2</li> </ul>	<ul style="list-style-type: none"> <li>• scroll horizontally with  4 or  6</li> <li>• activate/deactivate with  2 or  8</li> </ul>	<ul style="list-style-type: none"> <li>• input via the 10 numerical keys of the keyboard</li> <li>• delete with C</li> </ul>


#### Status indications

Several symbols are used for the status indications.

Fig. 4.4: Status indications (line 1)





## 4.4 Keyboard






The keyboard has 15 keys, including 3 function keys: ENTER,  and C.

Some keys have multiple functions. They can be used to enter data, to navigate through scroll lists as well as to execute special functions (e.g., reset of totalizers).





Tab. 4.3: General functions

ENTER	confirmation of selection or input
 + C + ENTER	Reset: press these 3 keys simultaneously to correct a malfunction. The reset has the same effect as a restart of the transmitter. Stored data are not affected.
 + C	INIT: When initializing the transmitter, all settings are reset to the factory settings.









Tab. 4.4: Navigation

	During the parameter input: short press: return to the previous menu item long press (several seconds): return to the beginning of the program branch During the measurement: display of scroll list: Stop measurement, Show parameters, Show measurement
 	scroll to the left/right through a scroll list
 	scroll upwards/downwards through a scroll list
ENTER	confirmation of a menu item

Tab. 4.5: Input of numbers

 ... 	input of the number pictured on the key
	sign for the input of negative values
	decimal marker
C	deletion of values After the value has been deleted, the previous value will be displayed.
ENTER	confirmation of the input

Tab. 4.6: Input of text

 	positioning of the cursor
	"A" is displayed and capitalization is activated
	"Z" is displayed and capitalization is activated
	toggle between upper and lower case
 	selection of the previous/next character
	deletion of a character and insertion of a blank
ENTER	confirmation of the input

## 5 Transport and storage

### Caution!

**When packaging, the transmitter can fall down.**

There is a danger of crushing body parts or damaging the measuring equipment.

- Secure the transmitter against falling during packaging.
- Wear the required personal protective equipment.
- Observe the applicable rules.

### Caution!

**When lifting, the center of gravity of the transmitter can be displaced within the cardboard box. The transmitter can fall down.**

There is a danger of crushing body parts or damaging the measuring equipment.

- Secure the transmitter against falling during transport.
- Wear the required personal protective equipment.
- Observe the applicable rules.

### 5.1 Transport

The measuring equipment must be packaged properly for transport. For weight indications, see technical specification.

- Use, if possible, the original packaging by FLEXIM or an equivalent cardboard box.
- Position the transmitter, transducers and accessories in the middle of the cardboard box.
- Fill any voids with appropriate packaging material (e.g., paper, foam, bubble wrap).
- Protect the cardboard box against humidity.

### 5.2 Storage

Store the measuring equipment in a dry place.

## 6 Mounting

### Danger!



#### **Risk of explosion when using the measuring equipment in explosive atmospheres (ATEX, IECEx)**

This may result in personal or material damage or dangerous situations.

→ Observe the "Safety instructions for the use in explosive atmospheres" (see document SIFLUXUS).

### Danger!



#### **Risk of explosion when using the measuring equipment in explosive atmospheres (TR TS)**

This may result in personal or material damage or dangerous situations.

→ Observe the "Safety instructions for the use in explosive atmospheres" (see document SIFLUXUSRU).

### Warning!



#### **Installation, connection and start-up by unauthorized and unqualified personnel**

This may result in personal or material damage or dangerous situations.

→ Any work on the transmitter has to be carried out by authorized and qualified personnel.

### Danger!



#### **Working in mines or cramped confines**

Risk of intoxication and/or asphyxiation because of emerging gases, risk of injuries because of cramped conditions.

→ Wear the required personal protective equipment.

→ Observe the applicable rules.

### Warning!



#### **Touching live parts**

Electric shock or arc faults can lead to severe injuries. The measuring equipment can be damaged.

→ Prior to any work on the transmitter (e.g., installation, dismantling, connection, start-up), the transmitter has to be disconnected from the power supply. It is not sufficient to remove the internal fuse of the instrument.

### Caution!



#### **Safety and accident prevention regulations for electrical systems and equipment**

Failure to observe these regulations may lead to severe injuries.

→ Observe the safety and accident prevention regulations for electrical systems and equipment.

### Caution!



#### **Touching hot or cold surfaces**

This may result in injuries (e.g., thermal damages).

→ Observe the ambient conditions at the measuring point during installation.

→ Wear the required personal protective equipment.

→ Observe the applicable rules.

**Important!**

Remove all protective foils before using the measuring equipment in explosive atmospheres (see document SIFLUXUS).

**6.1 Transmitter****6.1.1 Opening and closing the housing****6.1.1.1 Opening****Caution!****Possible danger by opening the equipment at improper ambient conditions**

Open the transmitter in safe ambient conditions only (e.g., air humidity < 90 %, no conductive pollution, no explosive atmosphere). Otherwise, additional protective measures have to be taken.

**Important!**

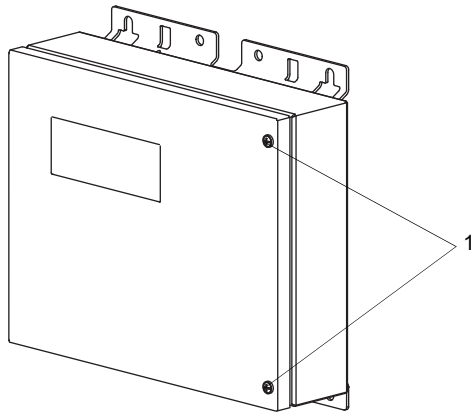
Do not use objects which may damage the housing gasket to open the housing cover.

- Loosen the screws of the transmitter housing.
- Open the housing cover of the transmitter.

**6.1.1.2 Closing****Transmitter with stainless steel housing**

- Close the housing cover.
- Tighten the screws of the transmitter housing with a max. torque of 1 Nm.

Fig. 6.1: Transmitter

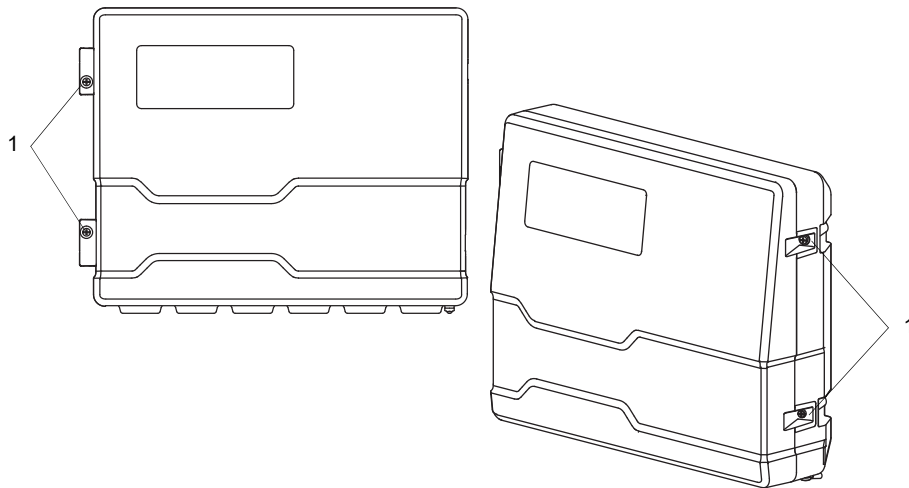


1 – screws

### Transmitter with aluminum housing

- Close the housing cover pressing it slightly upwards on the side of the screws.
- Hand-tight all screws of the transmitter housing.

Fig. 6.2: Transmitter



1 – screws

### 6.1.2 Installation of the transmitter

#### Notice!

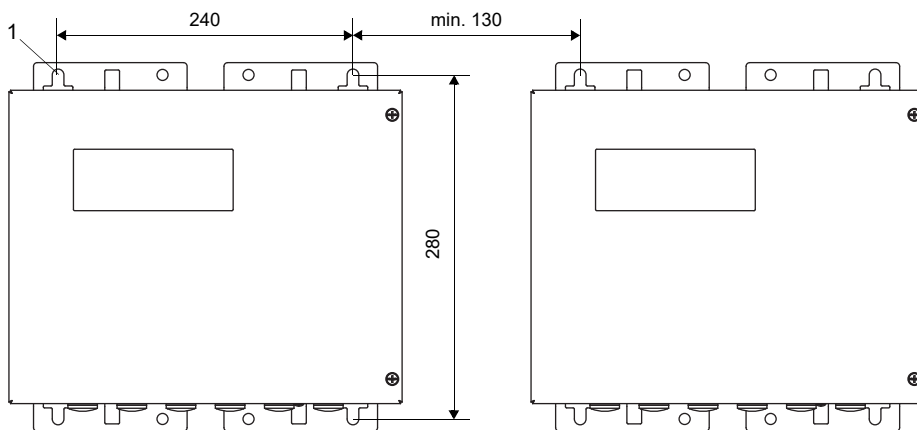
Install the equipment in a shady place, the cable glands facing downward. Observe the temperature and weight indications according to the technical specification when choosing the fixation elements and the place of installation.

#### 6.1.2.1 Wall mounting

##### Transmitter with stainless steel housing

- Fix the transmitter to the wall using 4 screws.

Fig. 6.3: Transmitter (dimensions in mm)



1 – fixing hole for wall mounting  $\varnothing$  9.5



**Transmitter with aluminum housing**

- Fix the wall mount (2) with 3 countersunk-head screws (3) firmly to the wall.
- Attach the transmitter (1) to the lower hooks (7) of the wall mount.
- Fix the transmitter to the wall mount by locking the stop bolt (4) into the destined hole and by firmly tightening the screw (5).

Fig. 6.4: Transmitter (dimensions in mm)

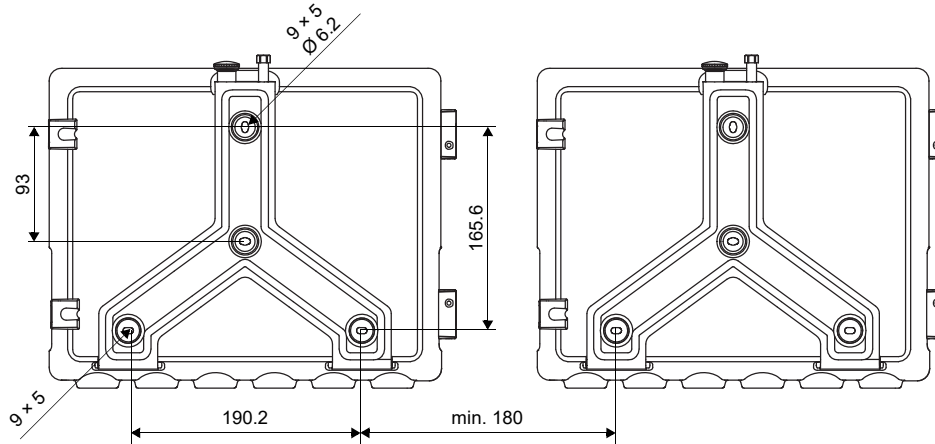
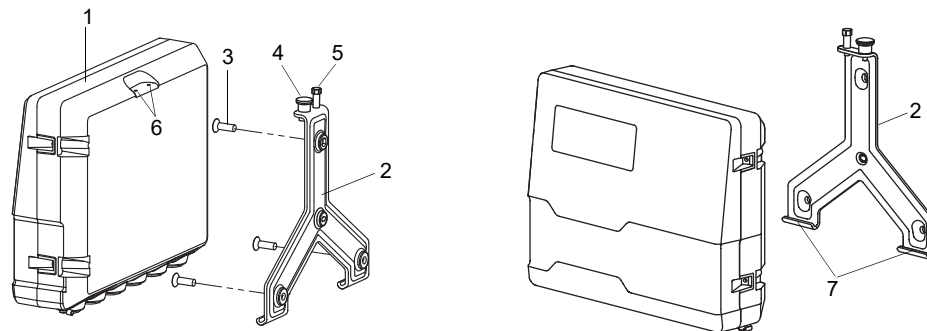


Fig. 6.5: Installation view



- 1 – transmitter
- 2 – wall mount
- 3 – countersunk-head screw
- 4 – stop bolt
- 5 – screw
- 6 – hole
- 7 – hook

### 6.1.2.2 Pipe mounting

#### Notice!

The pipe has to be sufficiently stable to withstand the pressure exerted by the transmitter and the shackles.

#### Transmitter with stainless steel housing

##### *Installation on a 2" pipe*

- Position the transmitter and the shackle (1) on the pipe.
- Fix the transmitter to the pipe by tightening the nuts (2) of the shackles.

##### *Mounting on a pipe > 2"*

The pipe mounting kit is fixed to the pipe by using tension straps.

#### Caution!



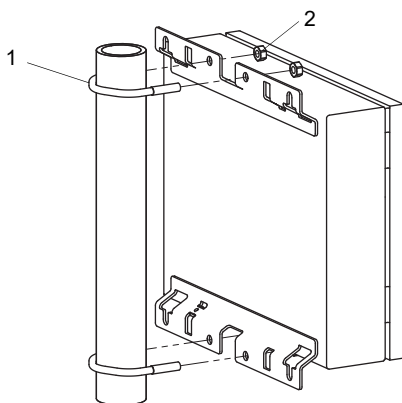
**The edge of the tension strap is very sharp.**

Risk of injury!

- Debur sharp edges.
- Wear the required personal protective equipment.
- Observe the applicable rules.

- Fix the transmitter to the pipe by using tension straps instead of shackles.

Fig. 6.6: Installation view



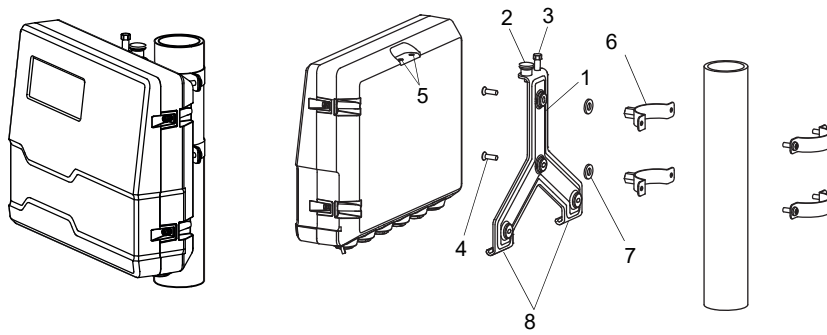
- 1 – shackle
- 2 – nut

**Transmitter with aluminum housing****Notice!**

For the mounting on pipes the pipe mounting kit, consisting of 2 band clamps, 2 countersunk-head screws and 2 washers, is needed. The distance of the band clamps has to be identical to the distance of the holes on the wall mount.

- Fix the band clamps (6) with 2 countersunk-head screws (4) firmly to the wall mount (1). Take care to place the washers (7) between the wall mount and the band clamp.
- Fix the wall mount with the band clamps to the pipe.
- Attach the transmitter to the lower hooks (8) of the wall mount.
- Fix the transmitter to the wall mount by locking the stop bolt (2) into the destined hole and by firmly tightening the screw (3).

Fig. 6.7: Installation view



- 1 – wall mount
- 2 – stop bolt
- 3 – screw
- 4 – countersunk-head screw
- 5 – hole
- 6 – band clamp
- 7 – washer
- 8 – hook

## 6.2 Transducers

### Caution!



#### Warning of severe injuries from hot or cold components

Touching hot or cold components can lead to severe injuries (e.g., thermal damage).

- Any mounting, installation or connection work has to be concluded.
- Any work on the measuring point during the measurement is prohibited.
- Observe the ambient conditions at the measuring point during installation.
- Wear the required personal protective equipment.
- Observe the applicable rules.

### 6.2.1 Preparation

#### 6.2.1.1 Measuring point selection

The correct selection of the measuring point is crucial for achieving reliable measurement results and a high measurement accuracy.

A measurement on a pipe is possible if:

- the ultrasound propagates with a sufficiently high amplitude
- the flow profile is fully developed

The correct selection of the measuring point and the correct transducer positioning guarantee that the sound signal will be received under optimum conditions and evaluated correctly.

Because of the variety of applications and the different factors that influence the measurement, there is no standard solution for the transducer positioning.

The measurement is influenced by the following factors:

- diameter, material, lining, wall thickness and shape of the pipe
- fluid
- gas bubbles in the fluid
- Avoid measuring points in the vicinity of distorted or defective areas of the pipe or in the vicinity of welds.
- Avoid measuring points with deposit formation in the pipe.
- Make sure the pipe surface at the selected measuring point is even.
- Select the location of the transmitter within the transducer cable range.
- The temperature at the measuring point has to be within the specific ambient temperature range of the transmitter and the transducers (see technical specification).

If the measuring point is within an explosive atmosphere, possibly present danger zones and gases have to be determined. The transducers and the transmitter have to be appropriate for these conditions.

#### 6.2.1.2 Pipe preparation

### Caution!



#### Contact with grinding dust

This may result in injuries (e.g., breathing difficulties, skin reactions, eye irritations).

- Wear the required personal protective equipment.
- Observe the applicable rules.

### Important!

The pipe has to be sufficiently stable to withstand the pressure exerted by the transducers and the fasteners.

### Notice!

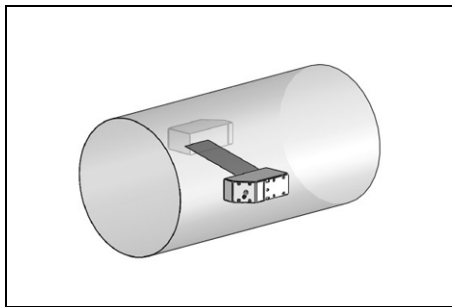
Observe the selection criteria of pipe and measuring point.

Rust, paint or deposits on the pipe absorb the sound signal. A good acoustic contact between the pipe and the transducers is obtained as follows:

- Clean the pipe at the selected measuring point.
  - If present, the paint layer has to be smoothed by grinding. The paint does not need to be removed completely.
  - Remove any rust or loose paint.

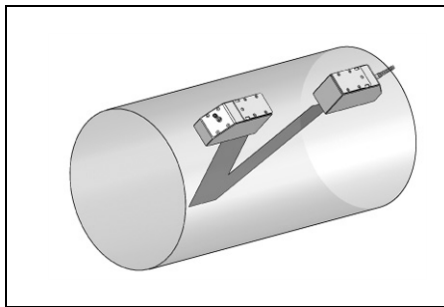
### 6.2.1.3 Selection of the measurement arrangement

#### Diagonal arrangement with 1 beam



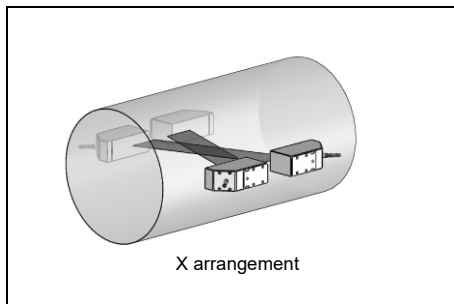
- wider flow velocity and sound speed range compared to the reflection arrangement
- use in the presence of deposits on the inner pipe wall or with strongly attenuating gases or liquids (only 1 sound path)

#### Reflection arrangement with 1 beam

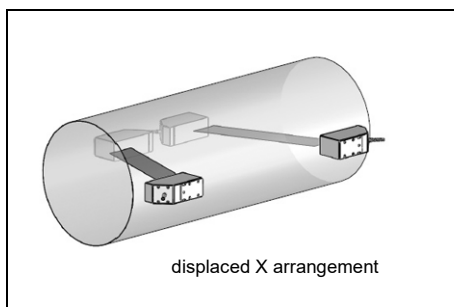
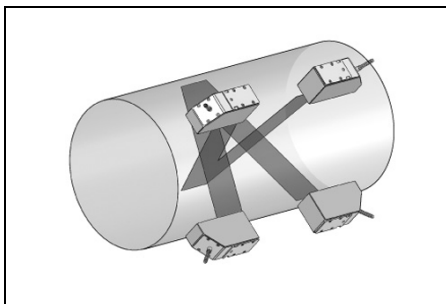


- smaller flow velocity and sound speed range compared to the diagonal arrangement
- cross-flow effects are compensated because the beam crosses the pipe in 2 directions
- higher accuracy of measurement because the accuracy increases with the number of sound paths

**Diagonal arrangement with 2 beams**



**Reflection arrangement with 2 beams and 2 planes**

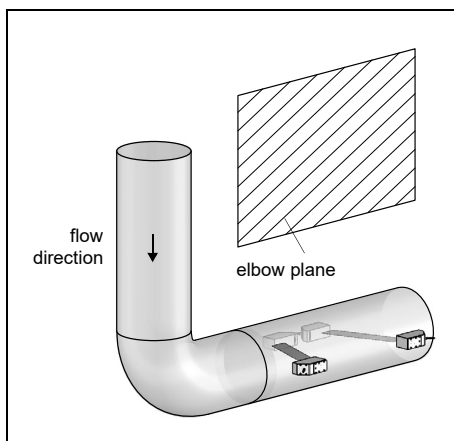


- same characteristics as reflection arrangement with 1 beam
- additional characteristic: influences of the flow profile are compensated because the measurement takes place in 2 planes

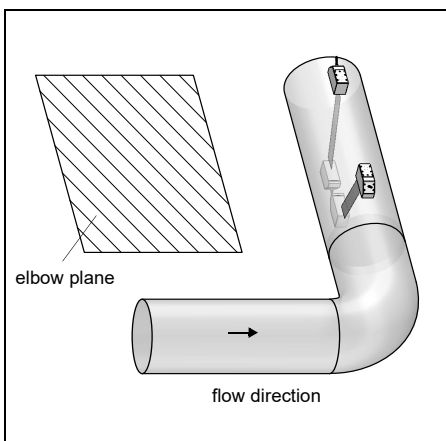
- same characteristics as diagonal arrangement with 1 beam
- additional characteristic: cross-flow effects are compensated because the measurement is conducted with 2 beams

If the measuring point is situated near an elbow, the following measurement arrangements are recommended for the selection of the sound beam plane.

**Vertical pipe**



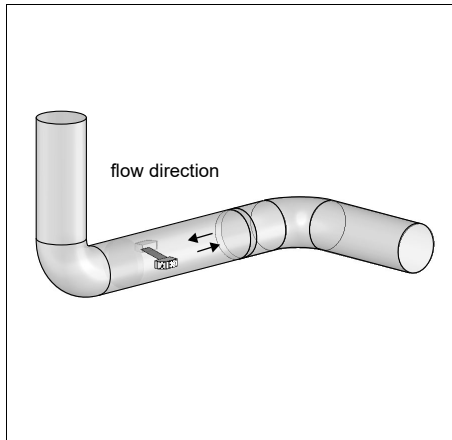
**Horizontal pipe**



- The sound beam plane is selected at an angle of  $90^\circ$  to the elbow plane. The elbow is upstream of the measuring point.

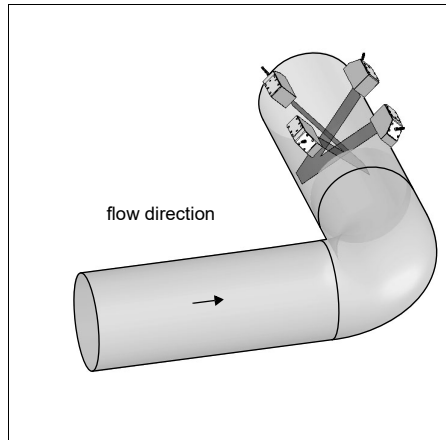
- The sound beam plane is selected at an angle of  $90^\circ \pm 45^\circ$  to the elbow plane. The elbow is upstream of the measuring point.

**Bidirectional measurement**



- The sound beam plane is selected according to the nearest elbow (horizontal or vertical, depending on the pipe orientation, see above).

**Measurement in reflection arrangement with 2 beams and 2 planes**



- The 2 sound beam planes are selected at an angle of 45° to the elbow plane. The elbow is upstream of the measuring point.
- On horizontal pipes, the transducers are mounted on the upper half of the pipe.

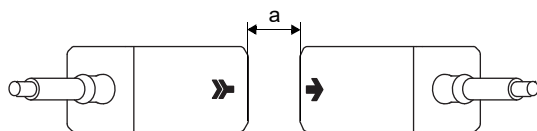
**6.2.2 Installation of the transducers**

**6.2.2.1 Orientation of the transducers and determination of the transducer distance**

Observe the orientation of the transducers. If the transducers have been mounted properly, the engravings on them form an arrow. The transducer cables show in opposite directions.

The transducer distance is measured between the inner edges of the transducers.

Fig. 6.8: Orientation and distance of the transducers



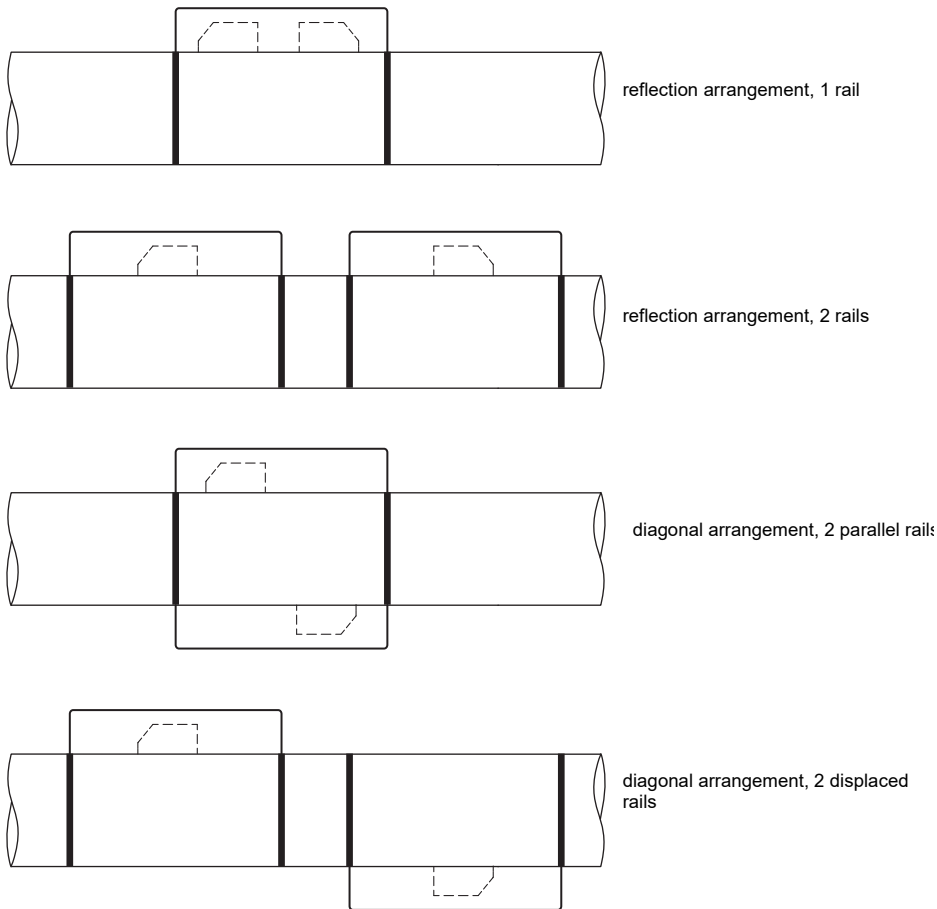
a – transducer distance

- Select the installation instructions of the supplied transducer mounting fixture.

### 6.2.2.2 Transducer arrangement

The transducers can be arranged in the mounting rails in different ways:

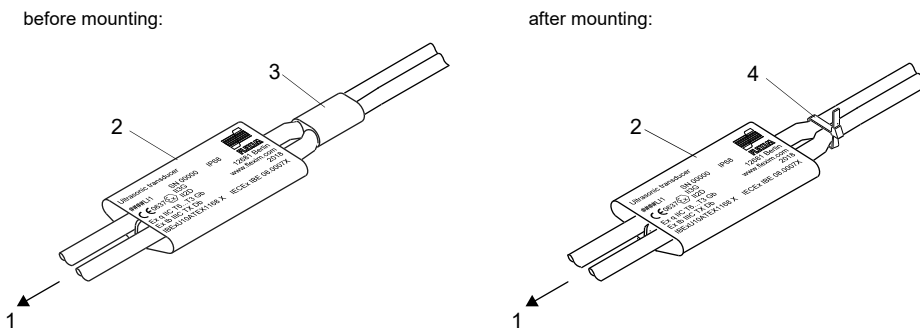
Fig. 6.9: Transducer arrangement in mounting rails



### 6.2.2.3 Mounting the transducers of type \*\*\*\*LI\*\*

If the nameplate of the transducers \*\*\*\*LI\*\* is removed from the transducer cable during installation, it has afterwards to be remounted and fixed to the transducer cable using the provided cable tie. The heat shrink tubing must not be reused.

Fig. 6.10: Nameplate on the transducer cable



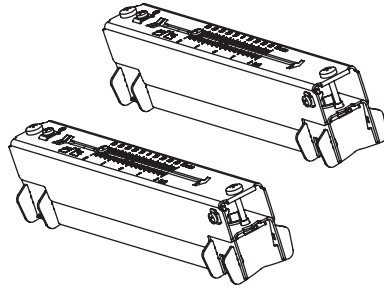
- 1 – transducers
- 2 – nameplate
- 3 – heat shrink tubing
- 4 – cable tie



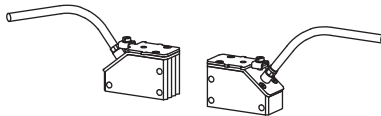
### 6.2.2.4 Mounting with Variofix L (PermaRail)

#### Scope of delivery (example)

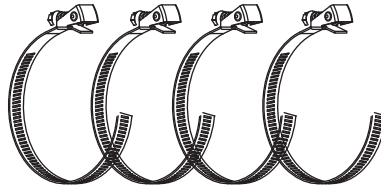
Variofix L



transducer pair

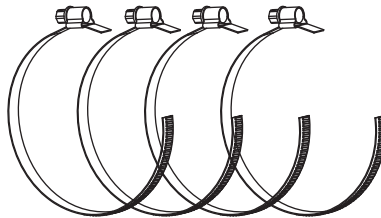


quick release clasp with tension strap



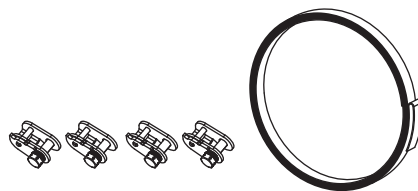
or

band clamp clasp with tension strap



or

ratchet clasp and tension strap coil



## Mounting

When measuring in diagonal arrangement, the transducer mounting fixtures are mounted on opposite sides of the pipe. When measuring in reflection arrangement, the transducer mounting fixtures are mounted on the same side of the pipe. When measuring in diagonal arrangement with 2 beams in displaced X arrangement, 4 transducer mounting fixtures have to be mounted. When measuring in reflection arrangement with a small transducer distance, only 1 transducer mounting fixture has to be mounted.

Tab. 6.1: Approximate values for the mounting of both transducers in a Variofix L

transducer frequency (3rd character of the technical type)	rail length [mm]	transducer distance [mm]
F	368	< 94
G, H, K (****LI*)	368	< 94
G, H, K (except ****LI*)	348	< 89
M, P (Lamb wave transducers)	234	< 84
M, P (shear wave transducers)		< 100
Q	176	< 69

In the following, the mounting of 2 transducer mounting fixtures in reflection arrangement is described (1 transducer mounting fixture for each transducer).

Fig. 6.11: Transducer mounting fixture Variofix L (diagonal arrangement)

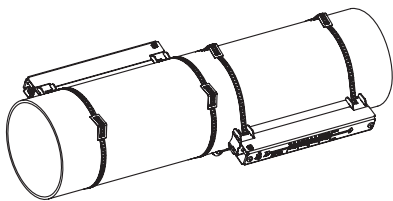
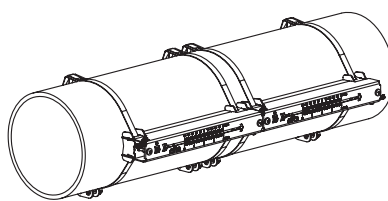


Fig. 6.12: Transducer mounting fixture Variofix L (reflection arrangement)



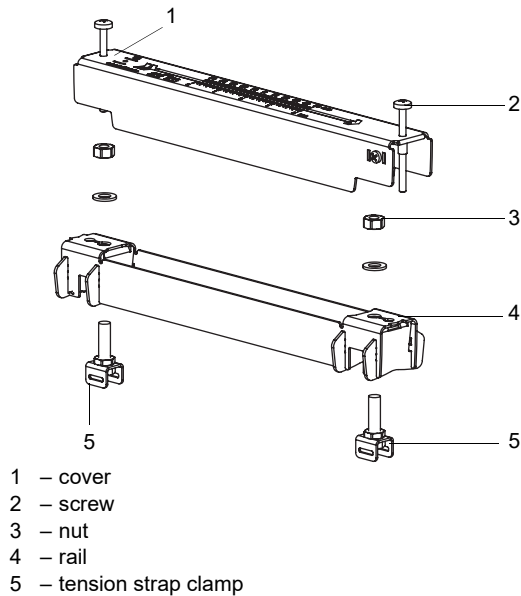
## Overview of mounting steps

- **step 1**  
disassembly of the transducer mounting fixture Variofix L
- **step 2**  
fixation of the clasps to the tension straps
- **step 3**  
fixation of the tension strap to the pipe
- **step 4**  
fixation of the rail to the pipe
- **step 5**  
installation of the transducers in the mounting fixture Variofix L

**Step 1: Disassembly of the transducer mounting fixture Variofix L**

- Disassemble the transducer mounting fixture Variofix L.

Fig. 6.13: Disassembly of the transducer mounting fixture Variofix L

**Step 2: Fixation of the clasps to the tension straps**

- Select the installation instruction of the supplied clasp:

**Band clamp clasp**

The clasp is fixed to the tension strap (see Fig. 6.14).

**Quick release clasp**

The clasp is fixed to the tension strap (see Fig. 6.15).

- Cut the tension strap to length (pipe circumference + at least 120 mm).

Fig. 6.14: Band clamp clasp with tension strap

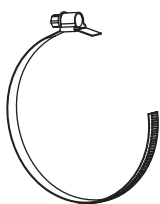
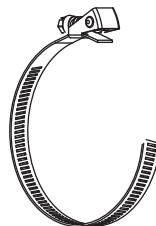


Fig. 6.15: Quick release clasp with tension strap

**Ratchet clasp**

- Cut the tension strap to length (pipe circumference + at least 120 mm).

**Caution!**

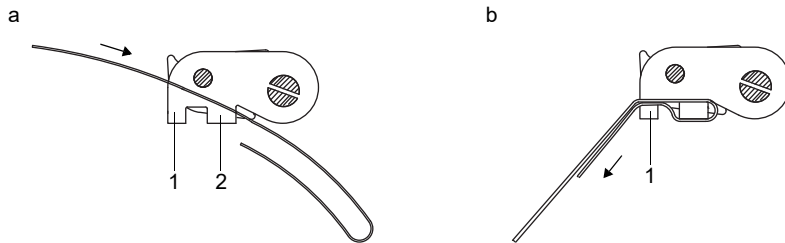
**The edge of the tension strap is very sharp.**

Risk of injury.

- Debur sharp edges.
- Wear the required personal protective equipment.
- Observe the applicable rules.

- Insert approx. 100 mm of the tension strap into part (1) and (2) of the ratchet clasp (see Fig. 6.16 a).
- Bend the tension strap.
- Insert the tension strap into part (1) of the ratchet clasp (see Fig. 6.16 b).
- Tighten the tension strap.
- Repeat the steps for the second tension strap.

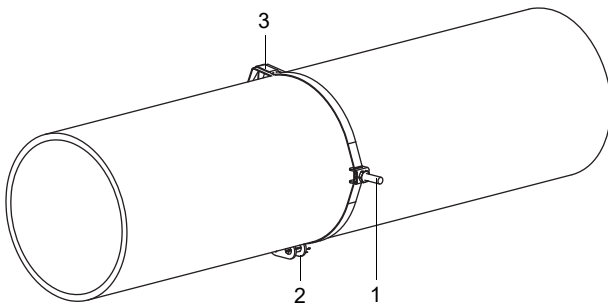
Fig. 6.16: Ratchet clasp with tension strap



### Step 3: Fixation of the tension strap to the pipe

One tension strap is fixed to the pipe. The second tension strap is mounted later.

Fig. 6.17: Tension strap with clamp and metal spring on the pipe



- 1 – tension strap clamp
- 2 – clasp
- 3 – metal spring

Select the installation instruction of the supplied clasp:

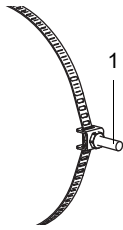
#### **Band clamp clasp**

- Insert the tension strap into its clamp (see Fig. 6.18).
- Position the clasp and the tension strap clamp on the pipe (see Fig. 6.17). On a horizontal pipe, mount the tension strap clamp laterally to the pipe, if possible.
- Place the tension strap around the pipe and insert it into the clasp (see Fig. 6.20).
- Tighten the tension strap.
- Tighten the clasp screw.

#### **Quick release clasp**

- Insert the tension strap into its clamp and the metal spring (see Fig. 6.18 and Fig. 6.19).
- Position the clasp, the tension strap clamp and the metal spring on the pipe (see Fig. 6.17):
  - On a horizontal pipe, mount the tension strap clamp laterally to the pipe, if possible.
  - Mount the metal spring opposite the tension strap clamp.

Fig. 6.18: Tension strap with clamp



1 – tension strap clamp

Fig. 6.19: Tension strap with quick release clasp and metal spring

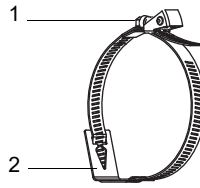
1 – clasp screw  
2 – metal spring

Fig. 6.20: Tension strap with band clamp clasp



1 – clasp screw

- Place the tension strap around the pipe and insert it into the clasp (see Fig. 6.19).
- Tighten the tension strap.
- Tighten the clasp screw.

**Ratchet clasp**

- Insert the tension strap into its clamp and the metal spring (see Fig. 6.21). The metal spring does not have to be mounted on:
  - steel pipes
  - pipes with an outer diameter < 80 mm
  - pipes that are not subjected to significant temperature fluctuations
- Position the ratchet clasp, tension strap clamp and metal spring (if necessary) on the pipe (see Fig. 6.17):
  - On a horizontal pipe, mount the tension strap clamp laterally to the pipe, if possible.
  - Mount the metal spring (if necessary) opposite the tension strap clamp.
- Place the tension strap around the pipe and pass it through the slot of the clasp screw (see Fig. 6.22).
- Tighten the tension strap.
- Cut off the protruding tension strap (see Fig. 6.22).

**Caution!****The edge of the tension strap is very sharp.**

Risk of injury.

- Debur sharp edges.
- Wear the required personal protective equipment.
- Observe the applicable rules.

- Tighten the clasp screw.

**Notice!**

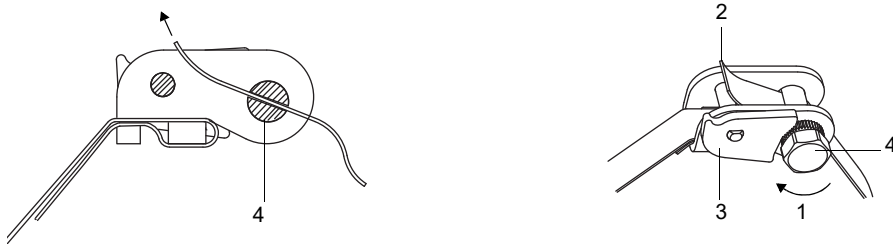
In order to release the screw and the tension strap, press the lever down (see Fig. 6.22).

Fig. 6.21: Tension strap with metal spring and clamp



- 1 – metal spring
- 2 – tension strap clamp

Fig. 6.22: Ratchet clasp with tension strap

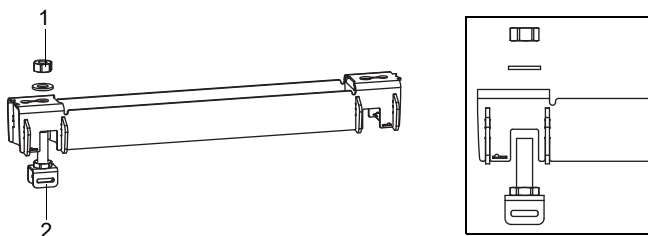


- 1 – sense of rotation
- 2 – edge
- 3 – lever
- 4 – clasp screw with slot

**Step 4: Fixation of the rail to the pipe**

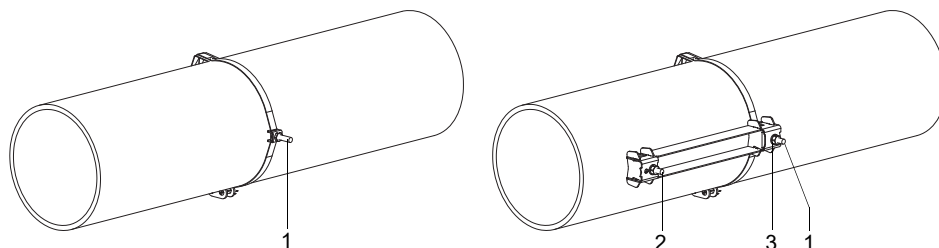
- Place the tension strap clamp (2) in the rail (see Fig. 6.23). Observe the orientation of the tension strap clamp.
- Slightly tighten the nut of the tension strap clamp (2).
- Screw the rail to tension strap clamp (1) (see Fig. 6.24).
- Tighten the nut of tension strap clamp (1), but not too firmly in order not to damage the tension strap.

Fig. 6.23: Rail with tension strap clamp



- 1 – nut
- 2 – tension strap clamp

Fig. 6.24: Rail, fixed on one side to the pipe



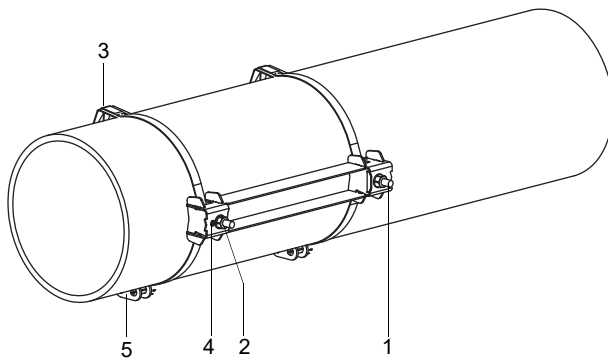
- 1 – tension strap clamp
- 2 – tension strap clamp
- 3 – nut

- Select the installation instruction of the supplied clasp:

**Band clamp clasp**

- Insert the tension strap into the tension strap clamp (2).
- Place the tension strap around the pipe and insert it into the clasp (see Fig. 6.25 and Fig. 6.26).
- Tighten the tension strap.
- Tighten the clasp screw.
- Tighten the nut of tension strap clamp (2), but not too firmly in order not to damage the tension strap.

Fig. 6.25: Rail on the pipe



- 1 – tension strap clamp
- 2 – tension strap clamp
- 3 – metal spring
- 4 – nut
- 5 – clasp

**Quick release clasp**

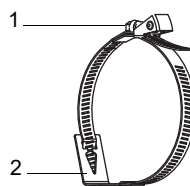
- Insert the tension strap into its clamp (2) and the metal spring.
- Place the tension strap around the pipe and insert it into the clasp (see Fig. 6.25 and Fig. 6.27).
- Position the metal spring opposite the tension strap clamp (2).
- Tighten the tension strap.
- Tighten the clasp screw.
- Tighten the nut of tension strap clamp (2), but not too firmly in order not to damage the tension strap.

Fig. 6.26: Tension strap with band clamp clasp



- 1 – clasp screw

Fig. 6.27: Tension strap with quick release clasp and metal spring




- 1 – clasp screw
- 2 – metal spring

**Ratchet clasp**

- Insert the tension strap into its clamp (2) and the metal spring (see Fig. 6.25 and Fig. 6.28). The metal spring does not have to be mounted on:
  - steel pipes
  - pipes with an outer diameter < 80 mm
  - pipes that are not subjected to significant temperature fluctuations
- Position the ratchet clasp, tension strap clamp (2) and metal spring (if necessary) on the pipe.
- Mount the metal spring opposite the tension strap clamp.
- Place the tension strap around the pipe and pass it through the slot of the clasp screw (see Fig. 6.29).
- Tighten the tension strap.
- Cut off the protruding tension strap (see Fig. 6.29).

**Caution!**



**The edge of the tension strap is very sharp.**  
Risk of injury.

- Debur sharp edges.
- Wear the required personal protective equipment.
- Observe the applicable rules.

- Tighten the clasp screw.
- Tighten the nut of the tension strap clamp (2), but not too firmly in order not to damage the tension strap (see Fig. 6.25).

**Notice!**

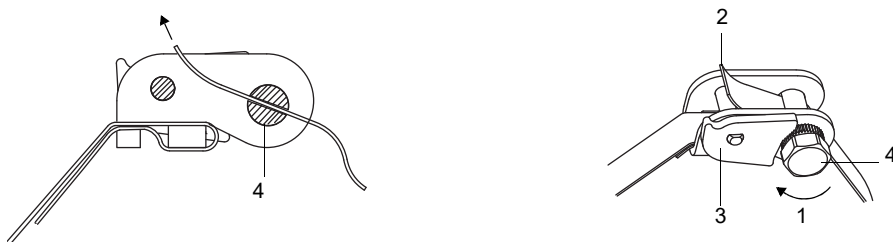
In order to release the screw and the tension strap, press the lever down (see Fig. 6.22).

Fig. 6.28: Tension strap with metal spring and clamp



- 1 – metal spring
- 2 – tension strap clamp

Fig. 6.29: Ratchet clasp with tension strap

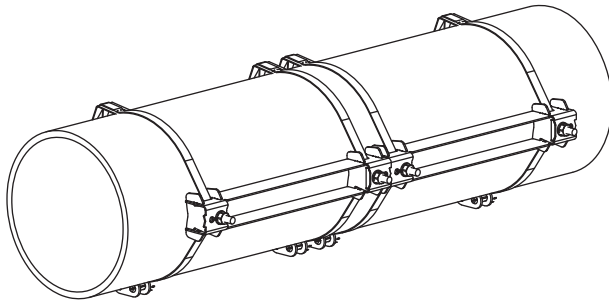


- 1 – sense of rotation
- 2 – edge
- 3 – lever
- 4 – clasp screw with slot



- Repeat the steps to fix the second rail, see Fig. 6.30.

Fig. 6.30: Pipe with 2 rails



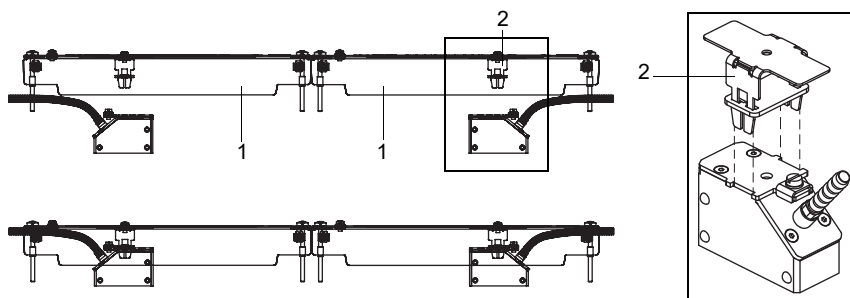
### Step 5: Installation of the transducers in the mounting fixture Variofix L

- Press the transducers firmly into their clamping fixtures in the covers until they are tightly fixed. The transducer cables show in opposite directions (see Fig. 6.31).

#### Notice!

The arrows on the transducers and the covers have to point in the same direction.

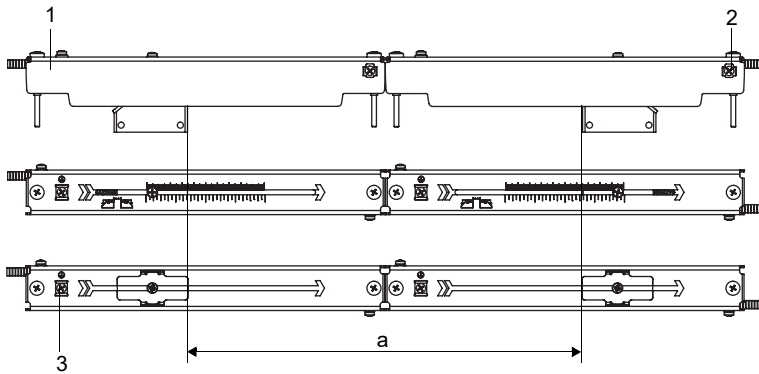
Fig. 6.31: Installation of the transducers in the covers



- 1 – cover  
2 – transducer clamping fixture

- Adjust the transducer distance displayed by the transmitter (see Fig. 6.32).
- Fix the transducer cables with the strain relief clamp to protect them from mechanical strain, see Fig. 6.32.
- Put coupling foil (or apply some coupling compound for a short-term installation) on the contact surface of the transducers. The coupling foil can be fixed to the contact surface with some coupling compound.
- Put the covers with the transducers on the rails.
- Correct the transducer distance, if necessary.

Fig. 6.32: Adjustment of the transducer distance



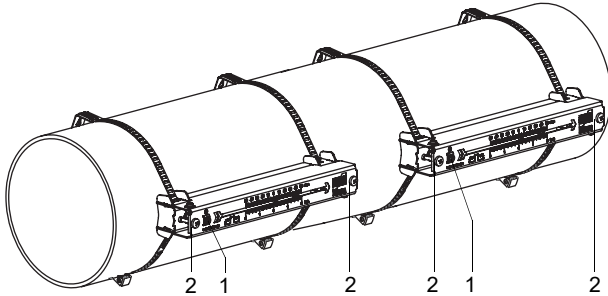
- 1 – cover
- 2 – strain relief clamp
- 3 – equipotential bonding terminal
- a – transducer distance

**Notice!**

Make sure that the coupling foil remains on the contact surface of the transducers. For information concerning the coupling foil, see the safety data sheet.

- Tighten the cover screws, see Fig. 6.33.

Fig. 6.33: Variofix L with transducers on the pipe

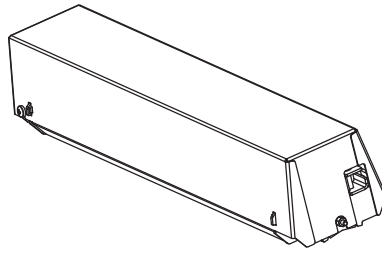


- 1 – equipotential bonding terminal
- 2 – cover screws

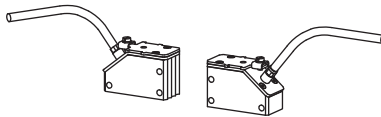
### 6.2.2.5 Mounting with Variofix C

#### Scope of delivery (example)

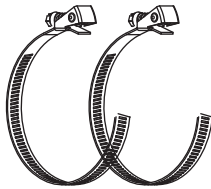
Variofix C



transducer pair

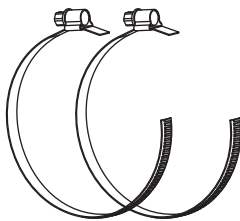


quick release clasp with tension strap



or

band clamp clasp with tension strap



or

tension strap coil



ratchet clasp



## Mounting

When measuring in reflection arrangement, 1 transducer mounting fixture is mounted laterally on the pipe.  
When measuring in diagonal arrangement, 2 transducer mounting fixtures are mounted on opposite sides of the pipe.  
In the following, the installation of 1 transducer mounting fixture in reflection arrangement is described.

Fig. 6.34: Transducer mounting fixture Variofix C (reflection arrangement)

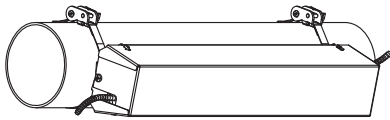
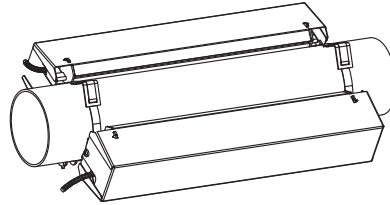


Fig. 6.35: Transducer mounting fixture Variofix C (diagonal arrangement)



### Overview of the mounting steps

- **step 1**  
disassembly of the transducer mounting fixture Variofix C
- **step 2**  
fixation of the clasps to the tension straps
- **step 3**  
fixation of the tension strap to the pipe
- **step 4**  
fixation of the rail to the pipe
- **step 5**  
installation of the transducers in the transducer mounting fixture Variofix C

**Step 1: Disassembly of the transducer mounting fixture Variofix C**

- Disassemble the transducer mounting fixture Variofix C.

In order to remove the cover from the rail, bend the outer sides of the cover outwards.

In order to remove the spring clip from the rail, slide it over the indentations on the rail and lift it off.

Fig. 6.36: Removal of the cover

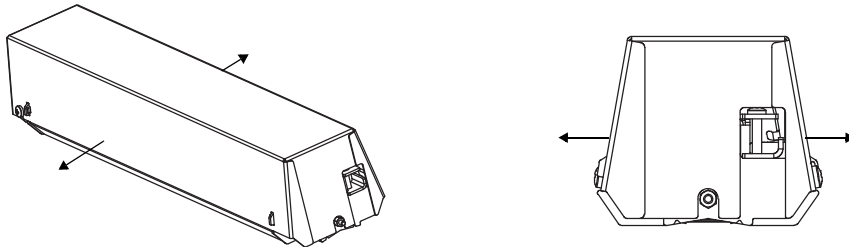
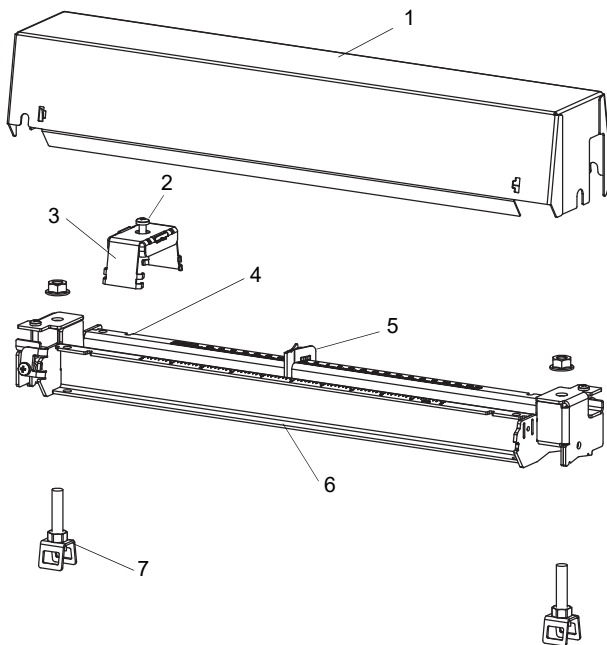


Fig. 6.37: Disassembly of the transducer mounting fixture Variofix C



- 1 – cover
- 2 – tensioning screw
- 3 – spring clip
- 4 – indentation
- 5 – spacing element
- 6 – rail
- 7 – tension strap clamp

**Step 2: Fixation of the clasps to the tension straps**

- Select the installation instruction of the supplied clasp:

**Band clamp clasp**

The clasp is fixed to the tension strap (see Fig. 6.38).

**Quick release clasp**

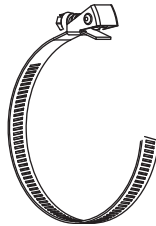
The clasp is fixed to the tension strap (see Fig. 6.39).

- Cut the tension strap to length (pipe circumference + at least 120 mm).

Fig. 6.38: Band clamp clasp with tension strap



Fig. 6.39: Quick release clasp with tension strap



**Ratchet clasp**

- Cut the tension strap to length (pipe circumference + at least 120 mm).

**Caution!**



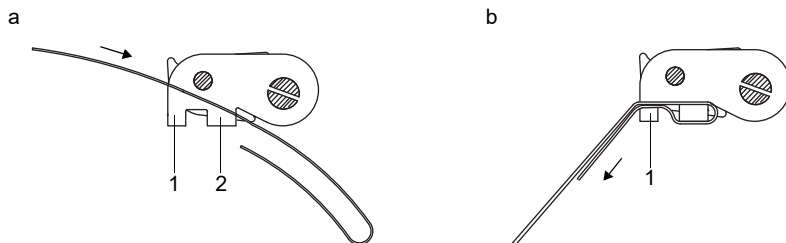
**The edge of the tension strap is very sharp.**

Risk of injury.

- Debur sharp edges.
- Wear the required personal protective equipment.
- Observe the applicable rules.

- Insert approx. 100 mm of the tension strap into part (1) and (2) of the ratchet clasp (see Fig. 6.40 a).
- Bend the tension strap.
- Insert the tension strap into part (1) of the ratchet clasp (see Fig. 6.40 b).
- Tighten the tension strap.
- Repeat the steps for the second tension strap.

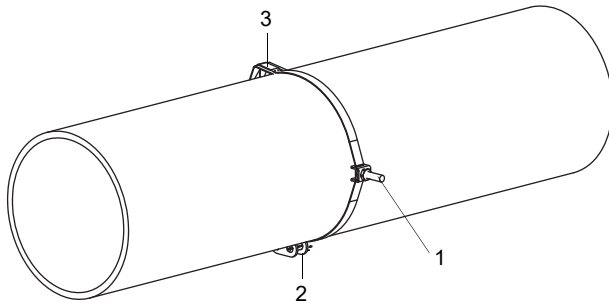
Fig. 6.40: Ratchet clasp with tension strap



**Step 3: Fixation of the tension strap to the pipe**

One tension strap is fixed to the pipe. The second tension strap is mounted later.

Fig. 6.41: Tension strap with clamp and metal spring on the pipe



- 1 – tension strap clamp
- 2 – clasp
- 3 – metal spring

Select the installation instruction of the supplied clasp:

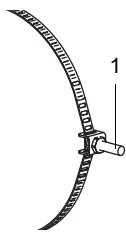
**Band clamp clasp**

- Insert the tension strap into its clamp (see Fig. 6.42).
- Position the clasp and the tension strap clamp on the pipe (see Fig. 6.41). On a horizontal pipe, mount the tension strap clamp laterally to the pipe, if possible.
- Place the tension strap around the pipe and insert it into the clasp (see Fig. 6.44).
- Tighten the tension strap.
- Tighten the clasp screw.

**Quick release clasp**

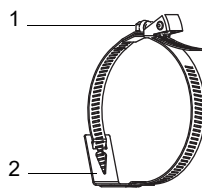
- Insert the tension strap into its clamp and the metal spring (see Fig. 6.42 and Fig. 6.43).
- Position the clasp, the tension strap clamp and the metal spring on the pipe (see Fig. 6.41):
  - On a horizontal pipe, mount the tension strap clamp laterally to the pipe, if possible.
  - Mount the metal spring opposite the tension strap clamp.

Fig. 6.42: Tension strap with clamp



- 1 – tension strap clamp

Fig. 6.43: Tension strap with quick release clasp and metal spring



- 1 – clasp screw
- 2 – metal spring

Fig. 6.44: Tension strap with band clamp clasp




- 1 – clasp screw

- Place the tension strap around the pipe and insert it into the clasp (see Fig. 6.43).
- Tighten the tension strap.
- Tighten the clasp screw.

**Ratchet clasp**

- Insert the tension strap into its clamp and the metal spring (see Fig. 6.45). The metal spring does not have to be mounted on:
  - steel pipes
  - pipes with an outer diameter < 80 mm
  - pipes that are not subjected to significant temperature fluctuations
- Position the ratchet clasp, tension strap clamp and metal spring (if necessary) on the pipe (see Fig. 6.41):
  - On a horizontal pipe, mount the tension strap clamp laterally to the pipe, if possible.
  - Mount the metal spring (if necessary) opposite the tension strap clamp.
- Place the tension strap around the pipe and pass it through the slot of the clasp screw (see Fig. 6.46).
- Tighten the tension strap.
- Cut off the protruding tension strap (see Fig. 6.46).

Caution!	
	<p><b>The edge of the tension strap is very sharp.</b> Risk of injury.</p> <ul style="list-style-type: none"> <li>→ Debur sharp edges.</li> <li>→ Wear the required personal protective equipment.</li> <li>→ Observe the applicable rules.</li> </ul>

- Tighten the clasp screw.

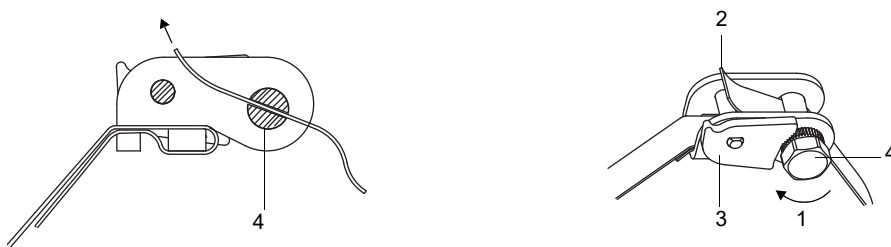
Notice!	
<p>In order to release the screw and the tension strap, press the lever down (see Fig. 6.46).</p>	

Fig. 6.45: Tension strap with metal spring and clamp



- 1 – metal spring
- 2 – tension strap clamp

Fig. 6.46: Ratchet clasp with tension strap



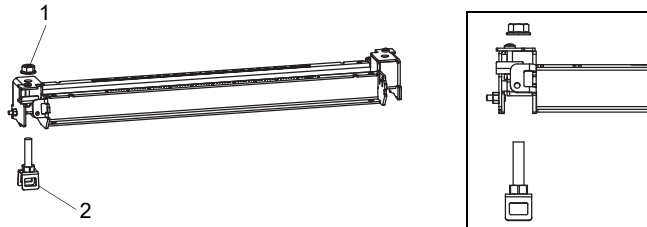
- 1 – sense of rotation
- 2 – edge
- 3 – lever
- 4 – clasp screw with slot



**Step 4: Fixation of the rail to the pipe**

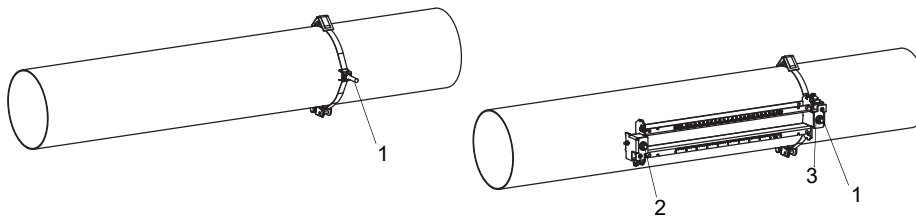
- Place the tension strap clamp (2) in the rail (see Fig. 6.47). Observe the orientation of the tension strap clamp.
- Slightly tighten the nut of the tension strap clamp (2).
- Screw the rail to tension strap clamp (1) (see Fig. 6.48).
- Tighten the nut of tension strap clamp (1), but not too firmly in order not to damage the tension strap.

Fig. 6.47: Rail with tension strap clamp



- 1 – nut
- 2 – tension strap clamp

Fig. 6.48: Rail, fixed on one side to the pipe



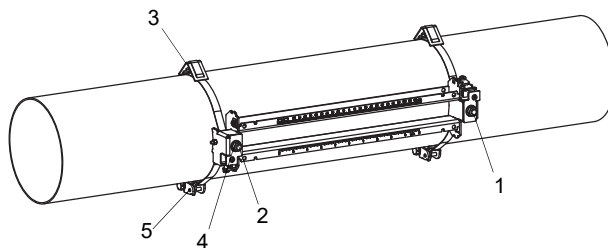
- 1 – tension strap clamp
- 2 – tension strap clamp
- 3 – nut

- Select the installation instruction of the supplied clasp:

**Band clamp clasp**

- Insert the tension strap into the tension strap clamp (2).
- Place the tension strap around the pipe and insert it into the clasp (see Fig. 6.49 and Fig. 6.50).
- Tighten the tension strap.
- Tighten the clasp screw.
- Tighten the nut of tension strap clamp (2), but not too firmly in order not to damage the tension strap. The rail has to be firmly fixed to the pipe.

Fig. 6.49: Rail on the pipe



- 1 – tension strap clamp
- 2 – tension strap clamp
- 3 – metal spring
- 4 – nut
- 5 – clasp

### Quick release clasp

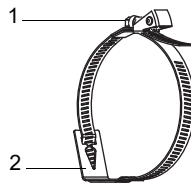
- Insert the tension strap into its clamp (2) and the metal spring.
- Place the tension strap around the pipe and insert it into the clamp (see Fig. 6.49 and Fig. 6.51).
- Position the metal spring opposite the tension strap clamp (2).
- Tighten the tension strap.
- Tighten the clasp screw.
- Tighten the nut of tension strap clamp (2), but not too firmly in order not to damage the tension strap.

Fig. 6.50: Tension strap with band clamp clasp



1 – clasp screw

Fig. 6.51: Tension strap with quick release clasp and metal spring



1 – clasp screw  
2 – metal spring

### Ratchet clasp

- Insert the tension strap into its clamp (2) and the metal spring (see Fig. 6.49 and Fig. 6.52). The metal spring does not have to be mounted on:
  - steel pipes
  - pipes with an outer diameter < 80 mm
  - pipes that are not subjected to significant temperature fluctuations
- Position the ratchet clasp, tension strap clamp (2) and metal spring (if necessary) on the pipe.
- Mount the metal spring opposite the tension strap clamp.
- Place the tension strap around the pipe and pass it through the slot of the clasp screw (see Fig. 6.53).
- Tighten the tension strap.
- Cut off the protruding tension strap (see Fig. 6.53).

#### Caution!



**The edge of the tension strap is very sharp.**

Risk of injury.

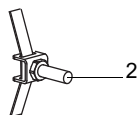
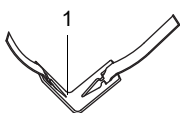
- Debur sharp edges.
- Wear the required personal protective equipment.
- Observe the applicable rules.

- Tighten the clasp screw.
- Tighten the nut of the tension strap clamp (2), but not too firmly in order not to damage the tension strap (see Fig. 6.49).

#### Notice!

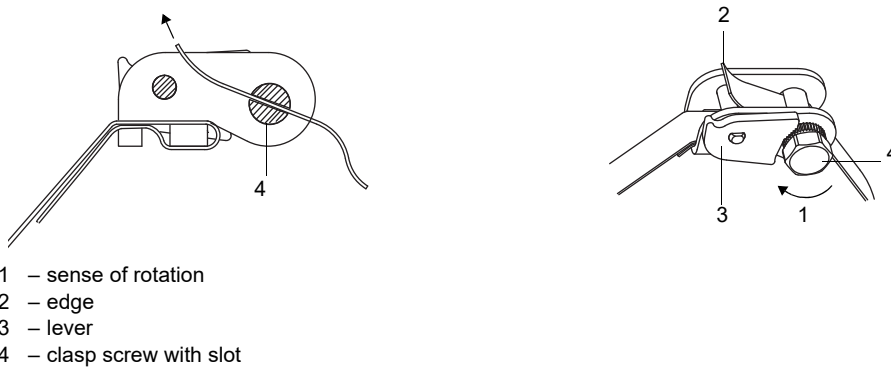
In order to release the screw and the tension strap, press the lever down (see Fig. 6.53).

Fig. 6.52: Tension strap with metal spring and clamp



1 – metal spring  
2 – tension strap clamp

Fig. 6.53: Ratchet clasp with tension strap



- 1 – sense of rotation
- 2 – edge
- 3 – lever
- 4 – clasp screw with slot

### Step 5: Installation of the transducers in the mounting fixture Variofix C

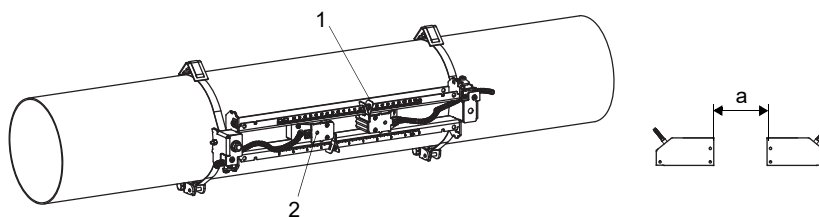
- Put coupling foil (or apply some coupling compound for a short-term installation) on the contact surface of the transducers. The coupling foil can be fixed to the contact surface with a small amount of coupling compound.

#### Notice!

If the signal is not sufficient for the measurement, use coupling compound instead of coupling foil. For information concerning the coupling foil or coupling compound, see the safety data sheet.

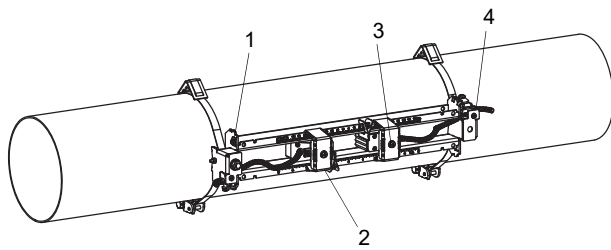
- Position the transducers on the rail in such a way that the engravings on them form an arrow. The transducer cables show in opposite directions (see Fig. 6.54).
- Adjust the transducer distance displayed by the transmitter (see Fig. 6.54).
- Slide the spring clips on the transducers (see Fig. 6.55).
- Fix the transducers by slightly tightening the tensioning screws. The end of each tensioning screw has to be placed above the hole in the respective transducer (see Fig. 6.54 and Fig. 6.55).
- Correct the transducer distance, if necessary.
- Tighten the tensioning screws.
- Fix the spacing elements on the rail to mark the transducer position (see Fig. 6.54).
- Use the cable fixture to fix the transducer cables in order to protect them from mechanical strain (see Fig. 6.55).
- Put the cover on the rail (see Fig. 6.56).
- Tighten the screws (2) on both sides of the cover (see Fig. 6.56).

Fig. 6.54: Transducers in the rail (spring clip not shown)



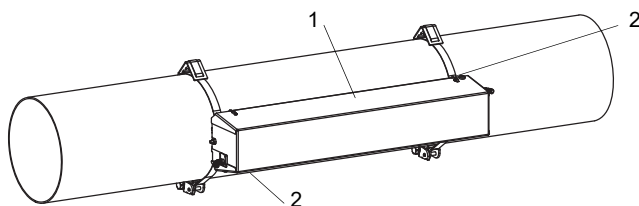
- 1 – spacing element
- 2 – hole
- a – transducer distance

Fig. 6.55: Transducers in the rail



- 1 – equipotential bonding terminal
- 2 – spring clip
- 3 – tensioning screw
- 4 – cable fixture

Fig. 6.56: Variofix C with transducers on the pipe

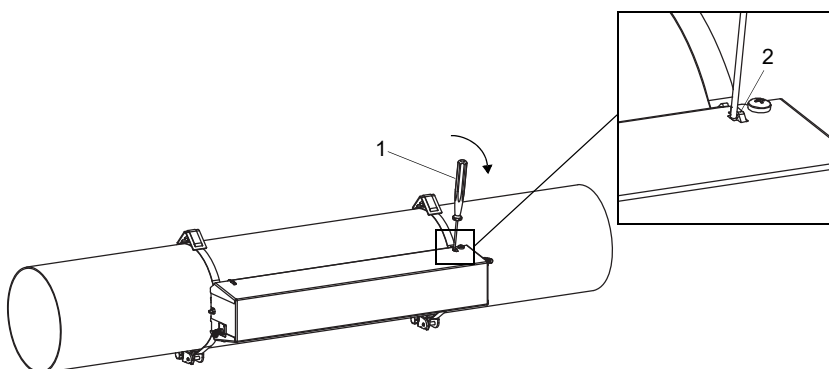


- 1 – cover
- 2 – screw

Remove the cover from the mounted transducer mounting fixture Variofix C as follows:

- Loosen the screws (see Fig. 6.56).
- Use a lever tool to remove the cover.
- Insert the lever tool (max. 3 mm) in one of the 4 openings of the cover (see Fig. 6.57).
- Press the lever tool against the fixture.
- Bend the cover outwards and release it from the anchoring.
- Repeat the steps for the other 3 openings.
- Remove the cover from the rail.

Fig. 6.57: Removal of the cover



- 1 – lever tool
- 2 – support

### 6.2.2.6 Installation with mounting shoe and band clamp clasp

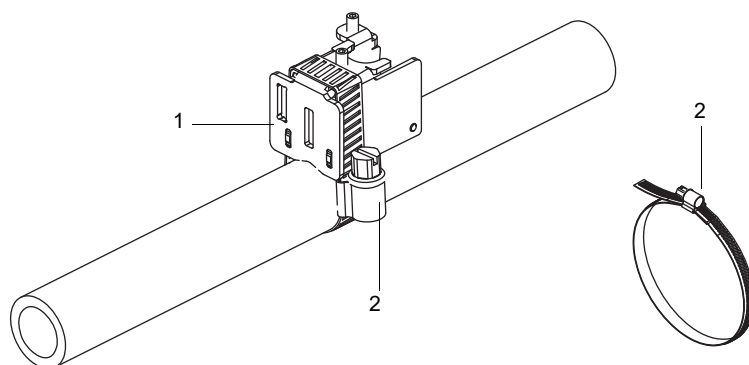
- Insert the tension strap into the groove on the upper side of the mounting shoe.
- Position the mounting shoe and the clasp on the pipe. On horizontal pipes, mount the mounting shoe laterally to the pipe, if possible.
- Place the tension strap around the pipe and insert it into the clasp.
- Tighten the tension strap.
- Tighten the screw of the clasp.

#### Notice!

The clasp has to be completely in contact with the pipe to ensure a good fixation.

- Repeat the steps for fixing the second mounting shoe.
- Adjust the displayed transducer distance between the inner edges of the mounting shoes by means of the measuring tape.
- Tighten the screws of the clasps.
- Slide the transducer into the mounting shoe.
- Press the transducer firmly on the pipe. There must not be a gap or any air pockets between the transducer surface and the pipe wall. Tighten the screw of the mounting shoe.
- Repeat the steps for the second transducer.

Fig. 6.58: Transducer in the mounting shoe, installed with tension strap and clasp



- 1 – mounting shoe  
2 – tension strap

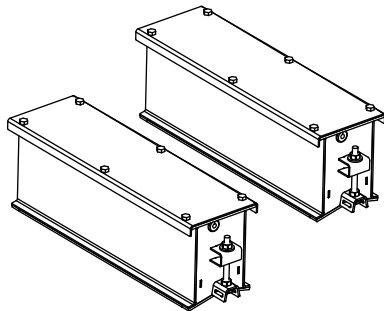
#### Notice!

If the transducers are mounted on a vertical pipe and the transmitter is placed lower than the transducers, the transducer cables should be fixed to the tension strap by a cable tie to protect them from mechanical strain.

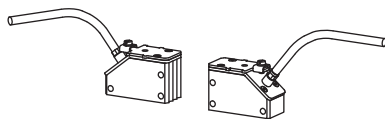
### 6.2.2.7 Mounting with PermaLok

#### Scope of delivery

2 × PermaLok



1 × transducer pair



4 × quick release clasp with tension strap

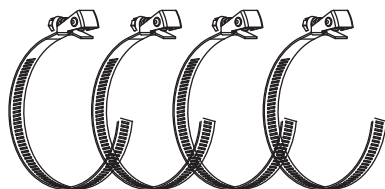
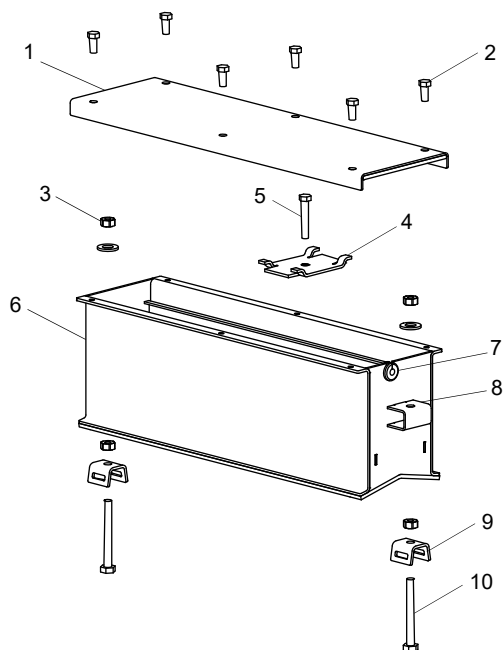


Fig. 6.59: PermaLok components



- 1 – cover
- 2 – screw
- 3 – nut
- 4 – slider
- 5 – screw of the slider
- 6 – rail
- 7 – cable gland
- 8 – fixture
- 9 – tension strap clamp (optional)
- 10 – bolt (optional)

## Mounting

When measuring in diagonal arrangement, the transducer mounting fixtures are mounted on opposite sides of the pipe (see Fig. 6.60). When measuring in reflection arrangement, the transducer mounting fixtures are mounted on the same side of the pipe (see Fig. 6.61).

In the following, the mounting of 2 transducer mounting fixtures in reflection arrangement is described (1 transducer mounting fixture for each transducer).

Fig. 6.60: Transducer mounting fixture PermaLok (diagonal arrangement)

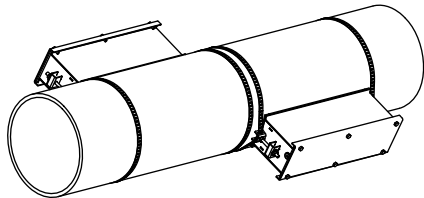
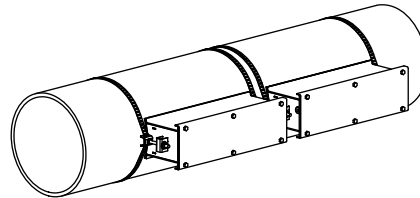


Fig. 6.61: Transducer mounting fixture PermaLok (reflection arrangement)



## Overview of the mounting steps

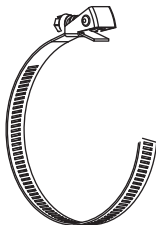
- **step 1**  
preparation
- **step 2**  
fixing the rail to the pipe
- **step 3**  
mounting of the transducers in the mounting fixture PermaLok

### Step 1: Preparation

- Remove the cover and slider of the PermaLok rail.
- Cut the tension strap to length (pipe circumference + 120 mm).

The clasp is fixed to the tension strap (see Fig. 6.62).

Fig. 6.62: Quick release clasp with tension strap



### Step 2: Fixing the rail to the pipe

- Insert the tension strap through the slot of the tension strap clamp (if present, see Fig. 6.63) or through the rail fixture (see Fig. 6.64).

Fig. 6.63: Tension strap through tension strap clamp

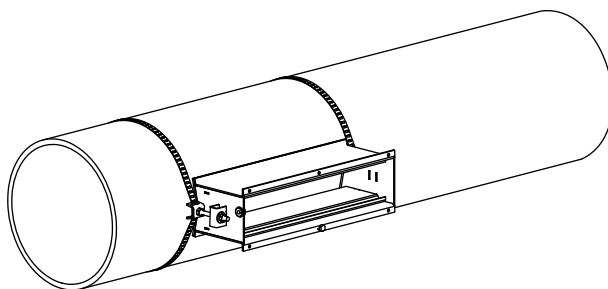
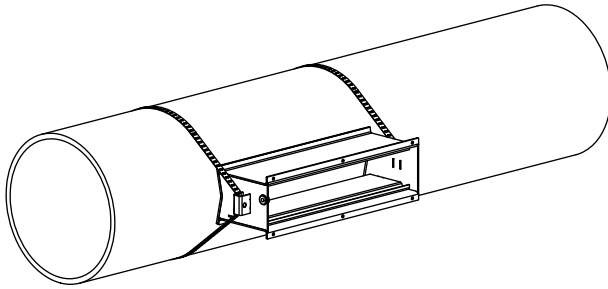


Fig. 6.64: Tension strap through rail fixture

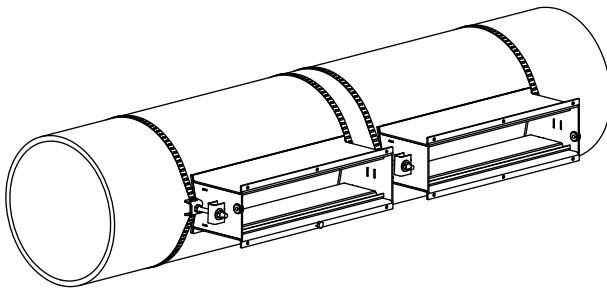


- Position the clasp on the pipe.
- Make sure, the clasp rests flatly along the pipe.
- Place the tension strap around the pipe and insert it into the clasp.
- Tighten the tension strap.
- Tighten the clasp screw.
- Repeat the steps for the second tension strap, but do not tighten too firmly.

Before fixing the rail to the pipe, it has to be assured that the rail and the pipe are aligned in parallel position.

- Repeat the steps for the second rail (see Fig. 6.65).

Fig. 6.65: Pipe with 2 rails

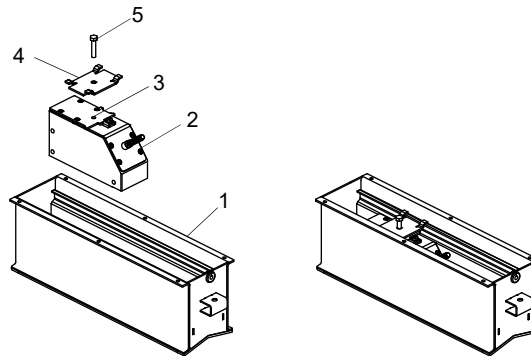




**Step 3: Mounting of the transducers in the mounting fixture PermaLok**

- Stick coupling foil (or some coupling compound for a short-term installation) on the contact surface of the transducer. The coupling foil can be fixed to the contact surface with a small amount of coupling compound.
- Insert the transducer into the rail.
- Position the slider on the transducer. The screw of the slider has to fit into the dugout on the top of the transducer (see Fig. 6.66).

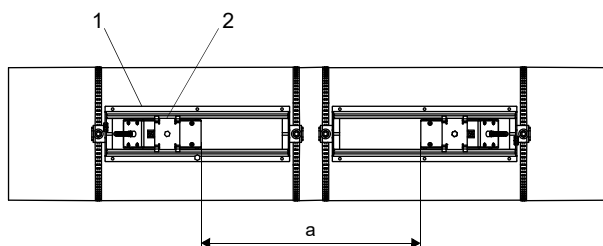
Fig. 6.66: Installation of the transducers



- 1 – rail
- 2 – transducer
- 3 – dugout
- 4 – slider
- 5 – screw of the slider

- Repeat the steps for the second transducer.
- Position the transducers on the rail in such way that the engravings on the transducers form an arrow. The transducer cables show in opposite directions.
- Adjust the transducer distance displayed by the transmitter (see Fig. 6.67).
- Tighten the screw of the slider until the transducers are firmly pressed to the pipe surface.
- Measure once again the transducer distance. Correct it, if necessary.
- Pass the transducer cables through the cable gland to protect them from mechanical strain.
- Check the transducer distance as described in section 9.3.
- Put the cover on the rail.
- Tighten the screws of the cover.

Fig. 6.67: Adjustment of the transducer distance



- 1 – rail
- 2 – slider
- a – transducer distance

### 6.2.2.8 Mounting with tension strap and quick release clasp

#### Caution!



**The edge of the tension strap is very sharp.**

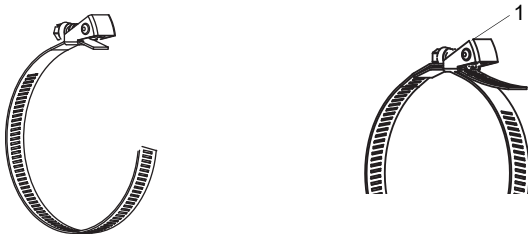
Risk of injury!

→ Debur sharp edges.

→ Wear the required personal protective equipment. Observe the applicable rules.

The clasp is fixed to the tension strap, see Fig. 6.78.

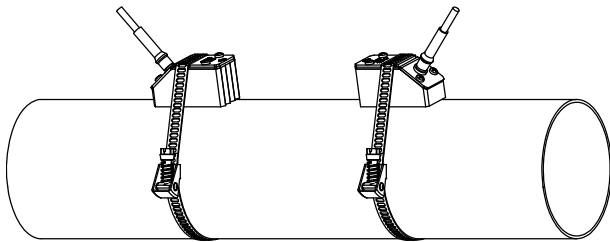
Fig. 6.68: Tension strap with quick release clasp



1 – clasp screw

- Cut the tension strap to length (pipe circumference + 120 mm).
- Position the transducer on the pipe, see Fig. 6.69.
- Place the tension strap around transducer and the pipe.
- Place the tension strap around the pipe and insert it into the clasp.
- The clasp has to be on the pipe.
- Tighten the tension strap.
- Tighten the clasp screw.

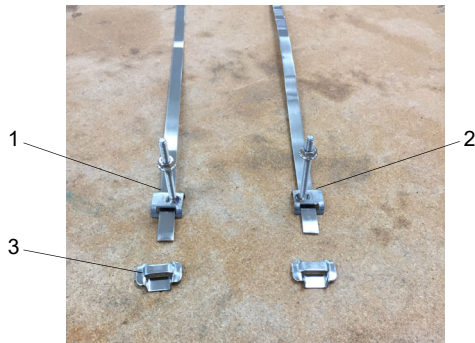
Fig. 6.69: Transducer on the pipe



### 6.2.2.9 Mounting of PermaLok with solid band strap kit

- Cut the tension strap to length (pipe circumference + at least 305 mm).
- Insert the solid band through the slot of the tension strap clamp.
- Line up the solid band, bolt and tension strap clamp observing the left and right side of the PermaLok (see Fig. 6.70).

Fig. 6.70:



- 1 – left tension strap clamp
- 2 – right tension strap clamp
- 3 – clip for fixation of the solid band

- Insert 25 mm of the solid band through the slot of the clip.
- Bend it back over the teeth and tighten with pliers (see Fig. 6.71).

Fig. 6.71



- Place the solid band around the pipe. Position the clip as shown in Fig. 6.72.
- Insert the other end of the solid band through the slot of the clip (see Fig. 6.73).

Fig. 6.72



Fig. 6.73



- Hold the tabs of the clip using pliers and pull the solid band completely through the slot of the clip (see Fig. 6.74).
- Bend the end of the solid band back over the set of teeth (see Fig. 6.75).

Fig. 6.74



Fig. 6.75



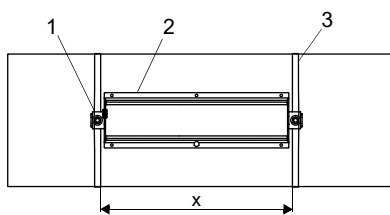
- Fold the tabs of the clip over the solid band and cut the protruding band off (see Fig. 6.76).

Fig. 6.76



- Position the tension strap clamp on the opposite side of the clip.
- Measure the distance  $x$  (see Fig. 6.77).
- Repeat the steps for the second band and place it at the measured distance  $x$  to the other.

Fig. 6.77



- 1 – tension strap clamp
- 2 – rail
- 3 – solid band

- Mount the PermaLok onto the tension strap clamp and tighten the bolts.
- Insert the transducers into the PermaLok as described in the section 6.2.2.7.

### 6.2.2.10 Mounting with tension strap and quick release clasp

#### Caution!



**The edge of the tension strap is very sharp.**

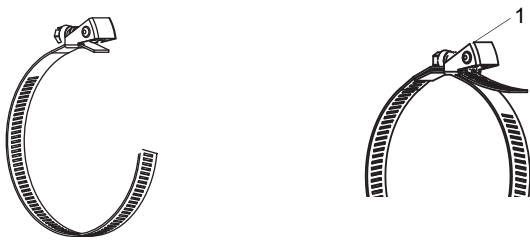
Risk of injury!

→ Debur sharp edges.

→ Wear the required personal protective equipment. Observe the applicable rules.

The clasp is fixed to the tension strap (see Fig. 6.78).

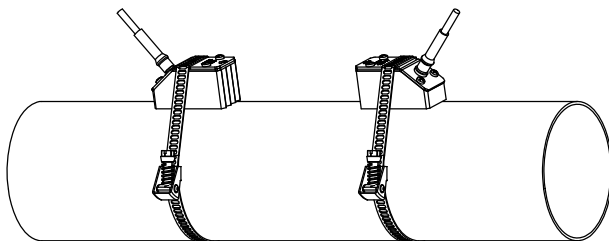
Fig. 6.78: Tension strap with quick release clasp



1 – clasp screw

- Cut the tension strap to length (pipe circumference + 120 mm).
- Position the transducer on the pipe (see Fig. 6.79).
- Place the tension strap around transducer and the pipe.
- Place the tension strap around the pipe and insert it into the clasp.
- The clasp has to be on the pipe.
- Tighten the tension strap.
- Tighten the clasp screw.

Fig. 6.79: Transducer on the pipe



## 6.3 Temperature probe

### 6.3.1 Pipe preparation

#### Caution!



#### Contact with grinding dust

This may result in injuries (e.g., breathing difficulties, skin reactions, eye irritations).

- Wear the required personal protective equipment.
- Observe the applicable rules.

#### Important!

The pipe has to be sufficiently stable to withstand the pressure exerted by the temperature probe.

Rust, paint or deposits on the pipe thermally insulate the measuring point. A good thermal contact between the pipe and the temperature probe is obtained as follows:

- Clean the pipe at the selected measuring point.
  - Remove any insulation material, rust or loose paint.
  - If present, the paint layer has to be smoothed by grinding. The paint does not need to be removed completely.
- Use coupling foil or apply a layer of thermal conductivity paste or coupling compound on the contact surface of the temperature probe. Observe the specific ambient temperature.
- Observe that there must be no air pockets between the contact surface of the temperature probe and the pipe wall.

### 6.3.2 Installation of the temperature probe (response time 50 s)

#### Notice!

The temperature probe has to be thermally insulated.

Select the installation instruction of the supplied clasp:

#### 6.3.2.1 Installation with clasp

#### Caution!



#### The edge of the tension strap is very sharp.

Risk of injury!

- Debur sharp edges.
- Wear the required personal protective equipment.
- Observe the applicable rules.

- Cut the tension strap to length (pipe circumference + at least 120 mm).
- Make sure that part (2) of the clasp is on top of part (1) (see Fig. 6.80 a). The hooks of part (2) have to be on the outer side of the clasp.
- Pull approx. 20 mm of the tension strap through the slot of the clasp to fix the clasp to the tension strap (see Fig. 6.80 b).
- Bend the end of the tension strap.
- Position the temperature probe on the pipe (see Fig. 6.81).
- Place the tension strap around the temperature probe and the pipe.
- Push the tension strap through part (2) and (1) of the clasp.
- Tighten the tension strap and engage it in the inner hook of the clasp.
- Tighten the screw of the clasp.

Fig. 6.80: Clasp

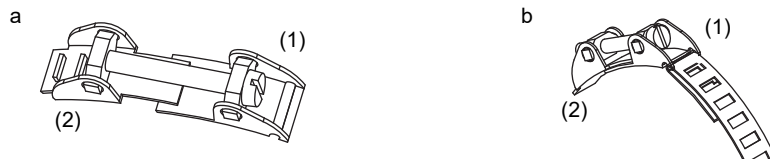
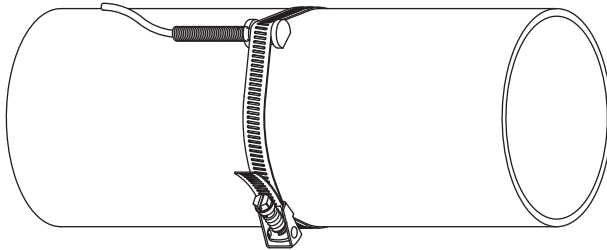


Fig. 6.81: Temperature probe on the pipe



### 6.3.2.2 Installation with FLEXIM clasp

#### Caution!



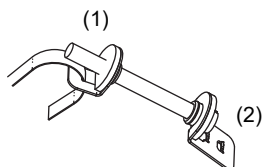
**The edge of the tension strap is very sharp.**

Risk of injury!

- Debur sharp edges.
- Wear the required personal protective equipment.
- Observe the applicable rules.

- Cut the tension strap to length (pipe circumference + at least 120 mm).
- Insert approx. 20 mm of the tension strap into the slot of the clasp.
- Bend the end of the tension strap.
- Position the temperature probe on the pipe (see Fig. 6.81).
- Place the tension strap around the temperature probe and the pipe.
- Push the tension strap through part (2) and (1) of the clasp.
- Tighten the tension strap and engage it in the inner hook of the clasp.
- Tighten the screw of the clasp.

Fig. 6.82: FLEXIM clasp



### 6.3.2.3 Installation with quick release clasp

#### Caution!



**The edge of the tension strap is very sharp.**

Risk of injury!

- Debur sharp edges.
- Wear the required personal protective equipment.
- Observe the applicable rules.

- Cut the tension strap to length (pipe circumference + at least 120 mm).
- Position the temperature probe on the pipe (see Fig. 6.81).
- Place the tension strap around the temperature probe and the pipe.
- Insert the tension strap into the clasp.
- Tighten the tension strap.
- Tighten the screw of the clasp.

Fig. 6.83: Quick release clasp

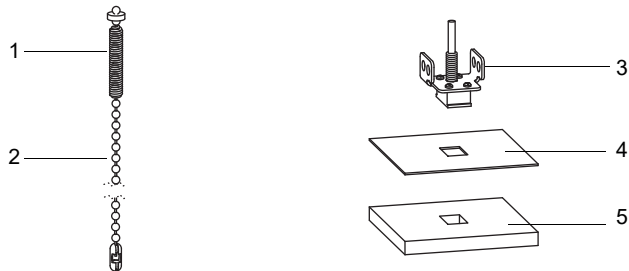




### 6.3.3 Installation of the temperature probe (response time 8 s)

- Fix the protection plate and the insulation foam to the temperature probe, see Fig. 6.84.
- Take the spring end of the chain and insert the first ball into one of the slots on the upper side of the temperature probe, see Fig. 6.85.
- Place the chain around the pipe.
- Tighten the chain and insert it into the other slot of the temperature probe.

Fig. 6.84: Temperature probe

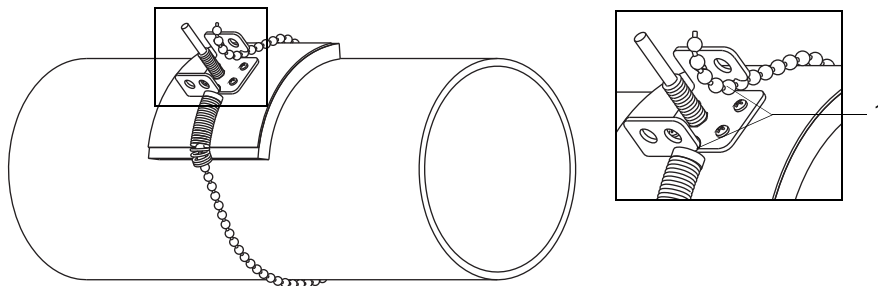


- 1 – spring end
- 2 – chain
- 3 – temperature probe
- 4 – protection plate
- 5 – insulation foam

#### Notice!

The entire contact surface of the temperature probe always has to rest on the pipe. In case of very small pipes, the protection plate and the insulation foam have to be cut to size, if necessary.

Fig. 6.85: Temperature probe on the pipe



- 1 – slots on the upper side of the temperature probe

## 7 Connection

### Danger!



#### **Risk of explosion when using the measuring equipment in explosive atmospheres (ATEX, IECEx)**

This may result in personal or material damage or dangerous situations.

→ Observe the "Safety instructions for the use in explosive atmospheres" (see document SIFLUXUS).

### Danger!



#### **Risk of explosion when using the measuring equipment in explosive atmospheres (TR TS)**

This may result in personal or material damage or dangerous situations.

→ Observe the "Safety instructions for the use in explosive atmospheres" (see document SIFLUXUSRU).

### Warning!



#### **Installation, connection and start-up by unauthorized and unqualified personnel**

This may result in personal or material damage or dangerous situations.

→ Any work on the transmitter has to be carried out by authorized and qualified personnel.

### Danger!



#### **Working in mines or cramped confines**

Risk of intoxication and/or asphyxiation because of emerging gases, risk of injuries because of cramped conditions.

→ Wear the required personal protective equipment.

→ Observe the applicable rules.

### Warning!



#### **Touching live parts**

Electric shock or arc faults can lead to severe injuries. The measuring equipment can be damaged.

→ Prior to any work on the transmitter (e.g., installation, dismounting, connection, start-up), the transmitter has to be disconnected from the power supply. It is not sufficient to remove the internal fuse of the instrument.

### Caution!



#### **Safety and accident prevention regulations for electrical systems and equipment**

Failure to observe these regulations may lead to severe injuries.

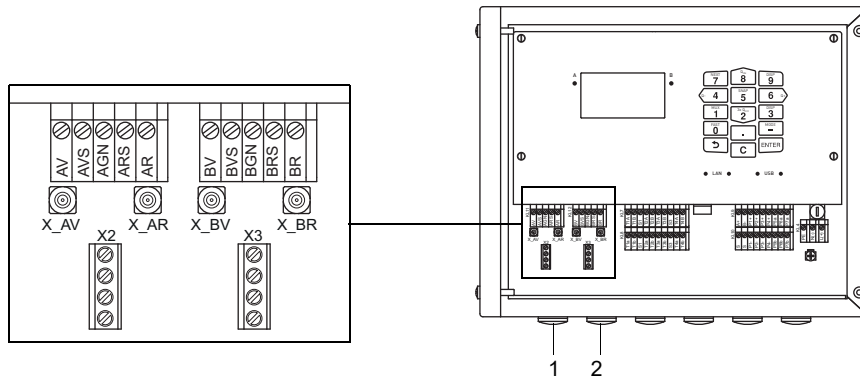
→ Observe the safety and accident prevention regulations for electrical systems and equipment.

## 7.1 Transducers

It is recommended to run the cables from the measuring point to the transmitter before connecting the transducers to avoid load on the connectors.

**Notice!**  
If transducers are replaced or added, the SENSPROM has to be replaced or added as well.

Fig. 7.1: Connection of the transducers to the transmitter



- 1 – transducers (measuring channel A)
- 2 – transducers (measuring channel B)

### 7.1.1 Connection of the transducer cable to the transmitter

**Important!**  
The degree of protection of the transmitter is only ensured if all cables are tightly fitted using cable glands and the housing is firmly screwed.

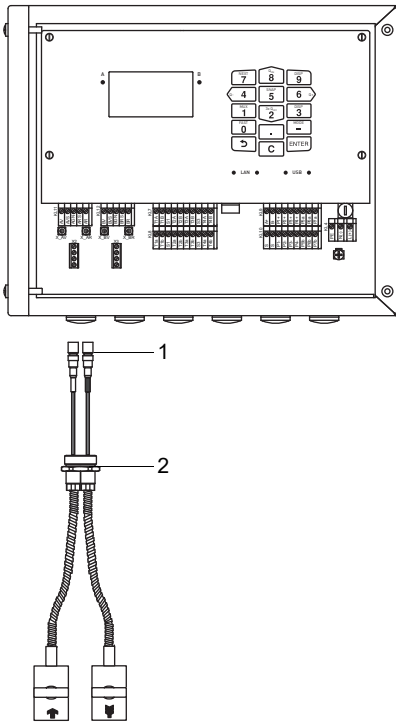
#### 7.1.1.1 Transducer cable with SMB connectors

- Remove the blind plug for the connection of the transducer cable.
- Insert the transducer cable with the SMB connectors into the housing.
- Fix the transducer cables by tightening the cable glands.
- Connect the SMB connectors to the sockets of the transmitter.

Tab. 7.1: Terminal assignment

terminal	connection
X_AV	SMB connector (brown cable, marked white)
X_AR	SMB connector (brown cable, marked black)

Fig. 7.2: Connection of the transducer cable with SMB connectors to the transmitter



- 1 – SMB connector
- 2 – cable gland

**7.1.1.2 Transducer cable with plastic jacket and stripped ends**

- Remove the blind plug for the connection of the transducer cable.
- Open the cable gland of the transducer cable. The compression part remains in the cap nut.
- Push the transducer cable through the cap nut and the compression part.
- Prepare the transducer cable.
- Shorten the external shield and brush it back over the compression part.
- Screw the sealing ring side of the basic part into the transmitter housing.
- Insert the transducer cable into the housing.

**Notice!**

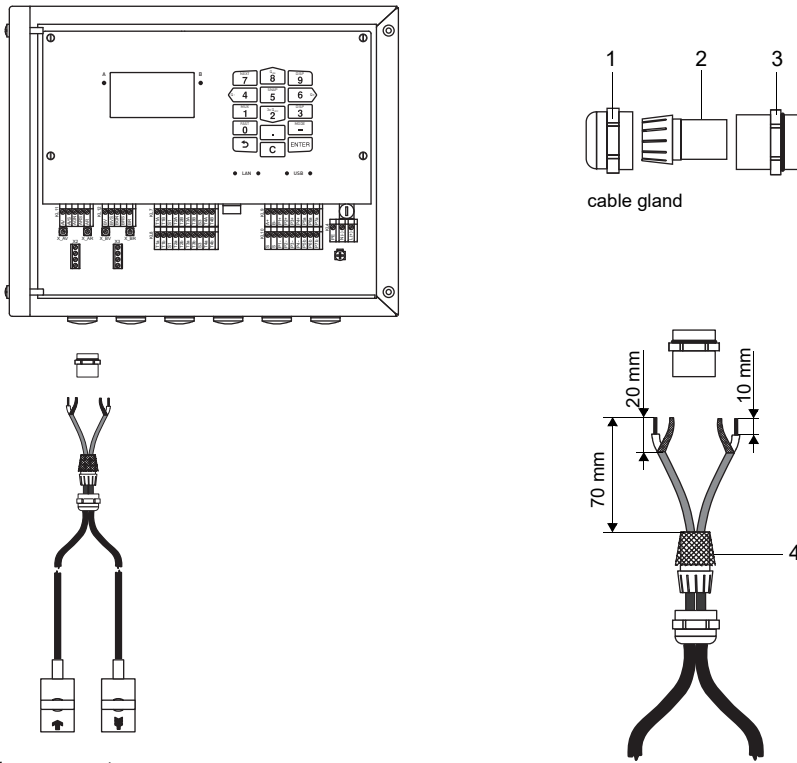
For good electromagnetic compatibility (EMC), it is important to ensure good electrical contact between the external shield and the cap nut (and thus the housing).

- Fix the cable gland by screwing the cap nut onto the basic part.
- Connect the transducer cable to the terminals of the transmitter.

Tab. 7.2: Terminal assignment

terminal	connection
AV	transducer  (core)
AVS	transducer  (internal shield)
ARS	transducer  (internal shield)
AR	transducer  (core)

Fig. 7.3: Connection of the transducer cable with plastic jacket and stripped ends to the transmitter



- 1 – cap nut
- 2 – compression part
- 3 – basic part
- 4 – external shield, brushed back

**7.1.1.3 Transducer cable with stainless steel conduit and stripped ends**

- Remove the blind plug for the connection of the transducer cable.
- Insert the transducer cable into the housing.
- Fix the transducer cable by tightening the cable gland.
- Connect the transducer cable to the terminals of the transmitter.

Tab. 7.3: Terminal assignment





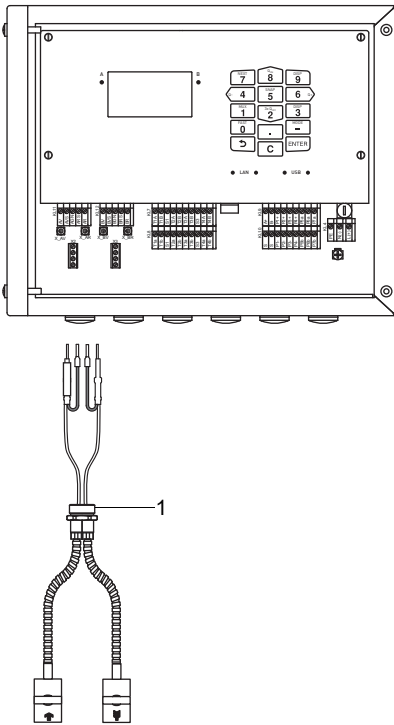
terminal	connection
AV	transducer  (brown cable, marked white)
AVS	transducer  (red cable)
ARS	transducer  (red cable)
AR	transducer  (brown cable)

Fig. 7.4: Connection of the transducer cable with stainless steel conduit and stripped ends to the transmitter



1 – cable gland

### 7.1.2 Connection of the extension cable to the transmitter

The extension cable is connected to the transmitter via the transducer connection.

- Remove the blind plug for the connection of the transducer cable.
- Open the cable gland of the extension cable. The compression part remains in the cap nut.
- Push the extension cable through the cap nut and the compression part.
- Prepare the extension cable.
- Shorten the external shield and brush it back over the compression part.
- Screw the sealing ring side of the basic part into the transmitter housing.
- Insert the extension cable into the housing.

#### Notice!

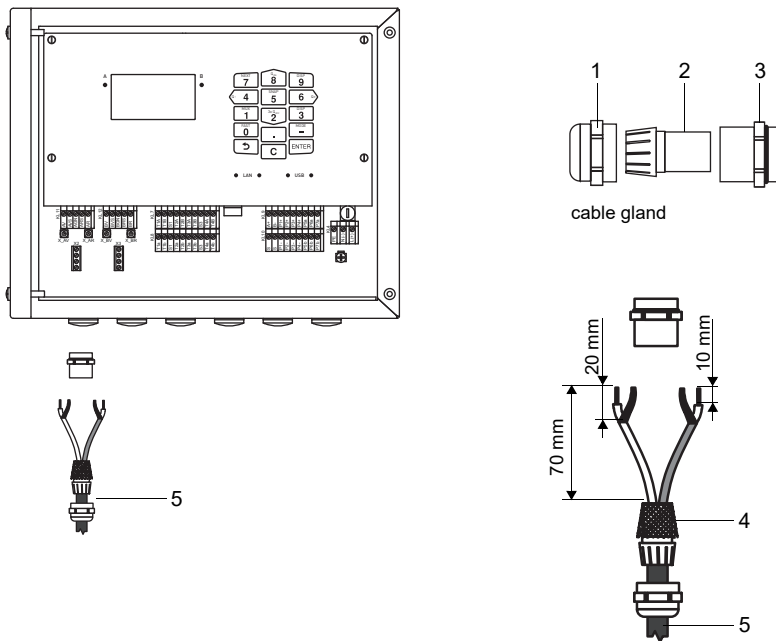
For good electromagnetic compatibility (EMC), it is important to ensure good electrical contact between the external shield and the cap nut (and thus the housing).

- Fix the cable gland by screwing the cap nut onto the basic part.
- Connect the extension cable to the terminals of the transmitter.

Tab. 7.4: Terminal assignment

terminal	connection
AV	white or marked cable (core)
AVS	white or marked cable (internal shield)
ARS	brown cable (internal shield)
AR	brown cable (core)

Fig. 7.5: Connection of the extension cable to the transmitter



- 1 – cap nut
- 2 – compression part
- 3 – basic part
- 4 – external shield, brushed back
- 5 – extension cable

### 7.1.3 Connection of the transducer cable to the junction box

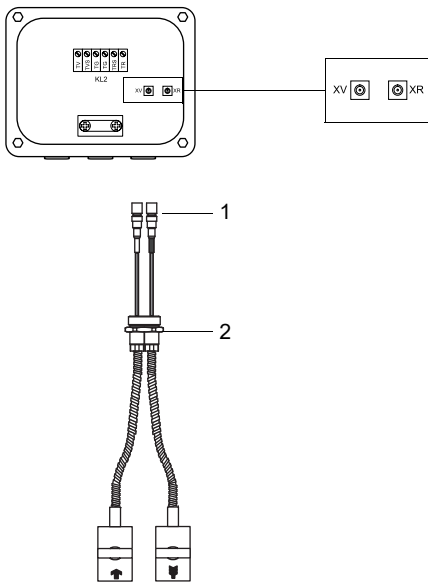
#### 7.1.3.1 Transducer cable with SMB connectors

- Remove the blind plug for the connection of the transducer cable.
- Insert the transducer cable with the SMB connectors into the junction box.
- Fix the transducer cable by tightening the cable gland.
- Connect the SMB connectors to the sockets of the junction box.

Tab. 7.5: Terminal assignment

terminal	connection
XV	SMB connector (brown cable, marked white)
XR	SMB connector (brown cable, marked black)

Fig. 7.6: Connection of the transducer cable with SMB connectors



- 1 – SMB connector
- 2 – cable gland

### 7.1.3.2 Transducer cable with plastic jacket and stripped ends

- Remove the blind plug for the connection of the transducer cable.
- Open the cable gland of the transducer cable. The compression part remains in the cap nut.
- Push the transducer cable through the cap nut and the compression part.
- Prepare the transducer cable.
- Shorten the external shield and brush it back over the compression part.
- Screw the gasket ring side of the basic part into the junction box.
- Insert the transducer cable into the junction box.

#### Notice!

For good electromagnetic compatibility (EMC), it is important to ensure good electrical contact between the external shield and the cap nut (and thus the housing).

- Fix the cable gland by screwing the cap nut onto the basic part.
- Connect the transducer cable to the terminals of the junction box.

Tab. 7.6: Terminal assignment





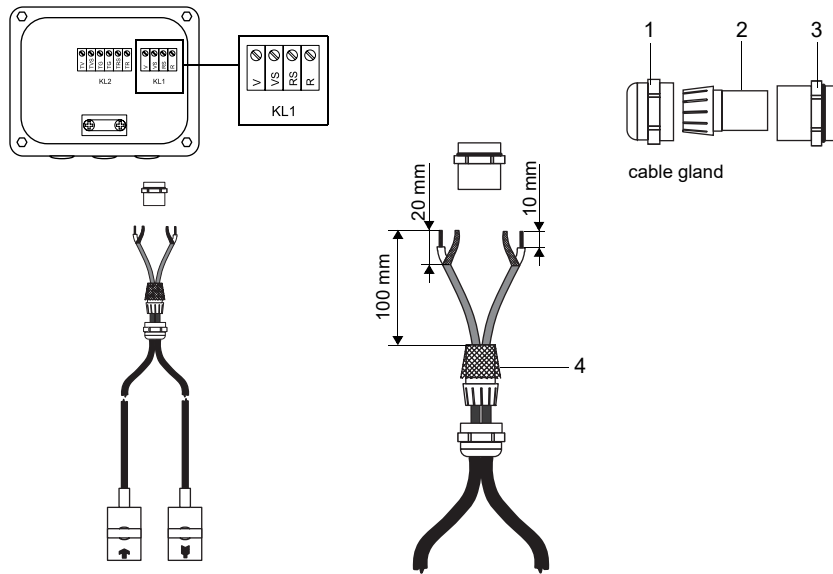
terminal	connection
V	transducer  (core)
VS	transducer  (internal shield)
RS	transducer  (internal shield)
R	transducer  (core)



Fig. 7.7: Connection of the transducer cable with plastic jacket and stripped ends



- 1 – cap nut
- 2 – compression part
- 3 – basic part
- 4 – external shield, brushed back

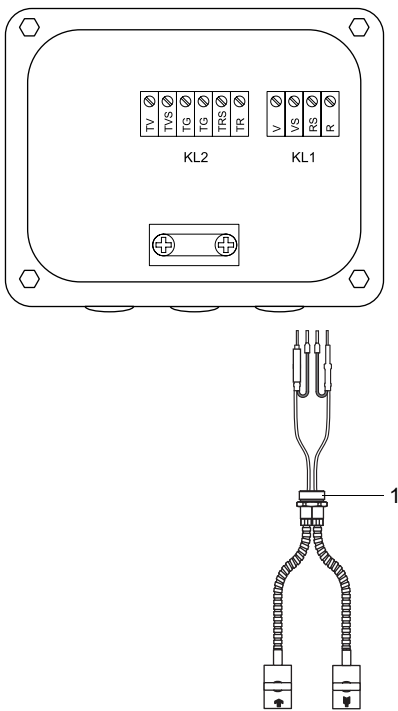
### 7.1.3.3 Transducer cable with stainless steel conduit and stripped ends

- Remove the blind plug for the connection of the transducer cable.
- Insert the transducer cable into the junction box.
- Fix the transducer cable by tightening the cable gland.
- Connect the transducer cable to the terminals of the junction box.

Tab. 7.7: Terminal assignment

terminal	connection
V	transducer  (brown cable, marked white)
VS	transducer  (red cable)
RS	transducer  (red cable)
R	transducer  (brown cable)

Fig. 7.8: Connection of the transducer cable with stainless steel conduit and stripped ends



1 – cable gland

#### 7.1.4 Connection of the extension cable to the junction box

##### 7.1.4.1 Connection without potential separation (standard)

The connection of the extension cable to the junction box without potential separation ensures that the transducer, junction box and transmitter are on the same potential. The extension cable should always be connected in this manner, especially if power current cables are nearby. If earthing on the same potential cannot be ensured, see section 7.1.4.2.

- Remove the blind plug for the connection of the extension cable.
- Open the cable gland of the extension cable. The compression part remains in the cap nut.
- Push the extension cable through the cap nut and the compression part.
- Prepare the extension cable.
- Shorten the external shield and brush it back over the compression part.
- Screw the gasket ring side of the basic part into the junction box.
- Insert the extension cable into the junction box.

#### Notice!

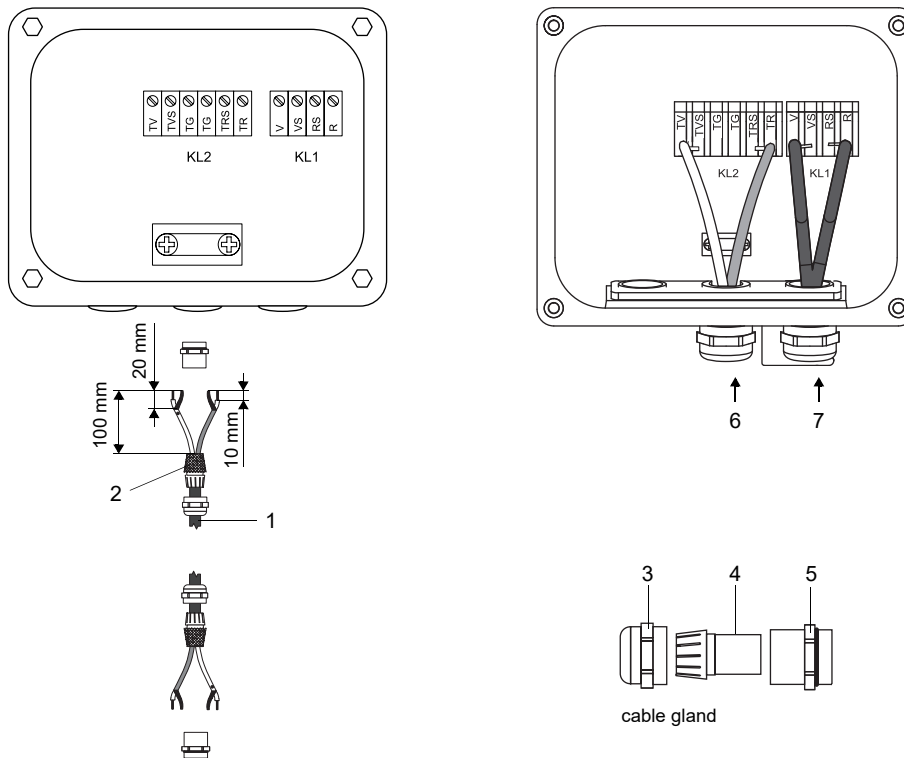
For good electromagnetic compatibility (EMC), it is important to ensure good electrical contact between the external shield and the cap nut (and thus the housing).

- Fix the cable gland by screwing the cap nut onto the basic part.
- Connect the extension cable to the terminals of the junction box.

Tab. 7.8: Terminal assignment

terminal	connection (extension cable)
TV	white or marked cable (core)
TVS	white or marked cable (internal shield)
TRS	brown cable (internal shield)
TR	brown cable (core)
cable gland	external shield

Fig. 7.9: Connection of the extension and transducer cable to the junction box



- 1 – extension cable
- 2 – external shield, brushed back
- 3 – cap nut
- 4 – compression part
- 5 – basic part
- 6 – connection of the extension cable
- 7 – connection of the transducer cable

### 7.1.4.2 Connection with potential separation

If earthing on the same potential cannot be ensured, e.g., in measurement arrangements with long extension cables, the extension cable and the junction box have to be electrically insulated from each other. The junction box and the transducers have to be on the same potential. Thus, no compensation currents can flow to the transmitter via the extension cable.

For measurement arrangements where the junction box and the transducers have to be electrically insulated from each other see the document TIFLUXUS\_GalvSep.

- Remove the blind plug for the connection of the extension cable.
- Open the cable gland of the extension cable. The compression part remains in the cap nut.
- Push the extension cable through the cap nut, the compression part and the basic part.
- Insert the extension cable into the junction box.
- Prepare the extension cable.
- Cut the external shield and brush it back.
- Pull the extension cable back until the brushed-back external shield is below the shield terminal. The extension cable has to remain completely insulated up to the shield terminal.
- Screw the gasket ring side of the basic part into the junction box.
- Fix the cable gland by screwing the cap nut onto the basic part.

<b>Important!</b>
Observe the max. permissible voltage of 60 V DC between the earth potentials.

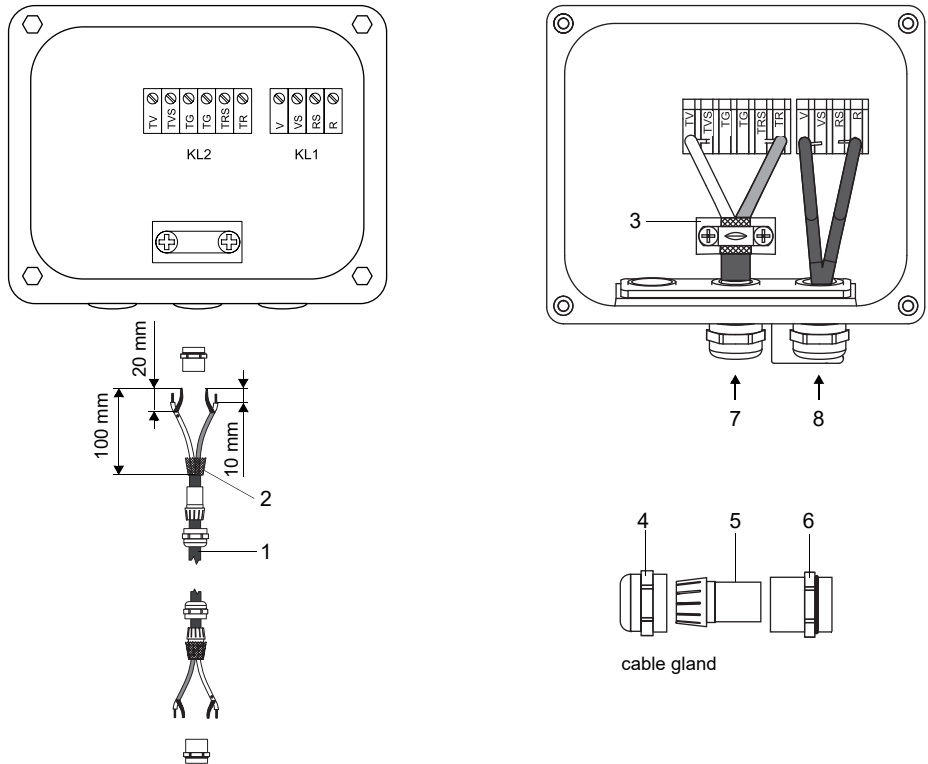
<b>Important!</b>
The external shield of the extension cable must not have electrical contact to the junction box. Therefore, the extension cable has to remain completely insulated up to the shield terminal.

- Fix the extension cable and the external shield to the shield terminal.
- Connect the extension cable to the terminals of the junction box.

Tab. 7.9: Terminal assignment

terminal	connection (extension cable)
TV	white or marked cable (core)
TVS	white or marked cable (internal shield)
TRS	brown cable (internal shield)
TR	brown cable (core)
shield terminal	external shield

Fig. 7.10: Connection of the extension and transducer cable to the junction box



- 1 – extension cable
- 2 – external shield
- 3 – shield terminal
- 4 – cap nut
- 5 – compression part
- 6 – basic part
- 7 – connection of the extension cable
- 8 – connection of the transducer cable

### 7.1.5 SENSPROM

The SENSPROM contains important transducer data for the operation of the transmitter with the transducers. If transducers are replaced or added, the SENSPROM has to be replaced or added as well.

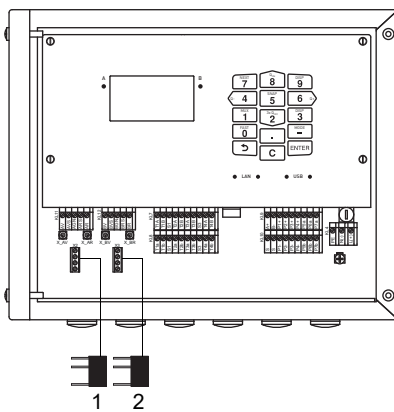
#### Notice!

The serial numbers of the SENSPROM and the transducer have to be identical. A wrong or wrongly connected SENSPROM will lead to incorrect measured values or to a measurement failure.

The SENSPROM is connected to the terminals of the transmitter.

- Disconnect the transmitter from the power supply.
- Connect the SENSPROM to the corresponding terminal.
- Connect the transmitter to the power supply.
- Enter all parameters of the program branch *Parameters*.
- Start the measurement.

Fig. 7.11: SENSPROM



- 1 – SENSPROM A
- 2 – SENSPROM B

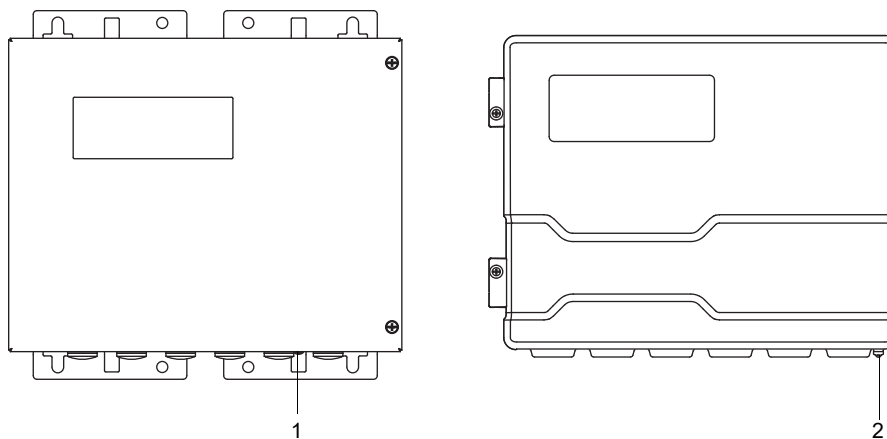
## 7.2 Power supply

The installation of the power supply is carried out by the operator. The operator has to provide an overcurrent protector (fuse or similar device) disconnecting all energizing wires in case of an inadmissible high current consumption. The impedance of the protective earth has to be low ohmic in order not to allow touch voltage pass the permissible limit. The equipotential bonding terminal serves as functional earth of the transmitter.

**Important!**

The degree of protection of the transmitter will only be guaranteed if the power cable fits firmly and tightly in the cable gland.

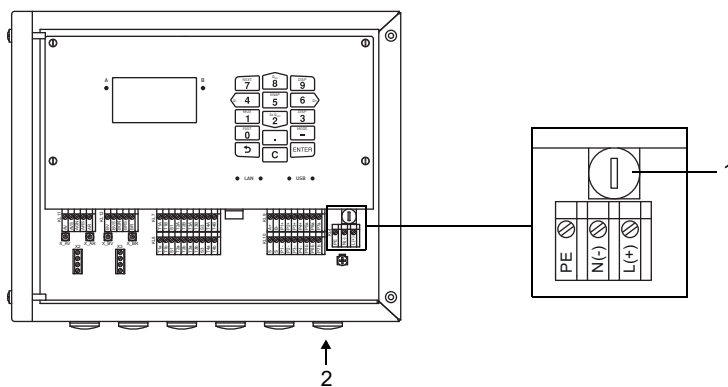
Fig. 7.12: Equipotential bonding terminal on the transmitter



- 1 – equipotential bonding terminal on stainless steel housing
- 2 – equipotential bonding terminal on aluminum housing

• Connect the power cable to the transmitter (see section 7.2.1, Fig. 7.13 and Tab. 7.10).

Fig. 7.13: Connection of the power supply to the transmitter



- 1 – fuse
- 2 – connection of the power supply

Tab. 7.10: Terminal assignment

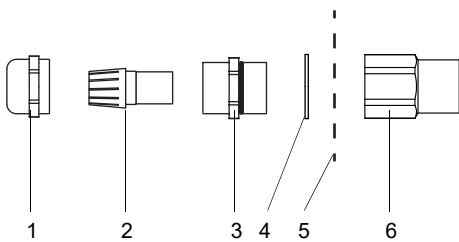
terminal	connection AC	connection DC
PE	earth	earth
N(-)	neutral	-
L(+)	phase 100...230 V AC, 50...60 Hz	+
fuse	1 A, time-lag	1.6 A, time-lag

### 7.2.1 Cable connection

#### Transmitter with stainless steel housing

- Remove the blind plug to connect the cable to the transmitter.
- Prepare the cable with a cable gland. The used cable has to have a wire cross-section of 0.25...2.5 mm<sup>2</sup>. The outer diameter of the cable where the ferrite nut is placed may not exceed 7.6 mm.
- Push the cable through the cap nut, compression part, basic part and the sealing ring (sealing ring: only for cable gland M20, not for cable gland 1/2 NPS).
- Insert the cable into the transmitter housing.
- Fix the cable gland by screwing the cap nut onto the basic part.
- Fix the transducer cable by tightening the cable gland with the ferrite nut.
- Connect the cable to the terminals of the transmitter.

Fig. 7.14: Cable gland for stainless steel housing



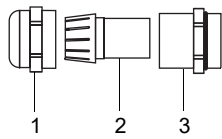
- 1 – cap nut
- 2 – compression part
- 3 – basic part
- 4 – sealing ring (only for cable gland M20, not for cable gland 1/2 NPS)
- 5 – housing wall
- 6 – ferrite nut

#### Transmitter with aluminum housing

- Remove the blind plug to connect the cable to the transmitter.
- Prepare the cable with a cable gland.  
 The used cable has to have a wire cross-section of 0.25...2.5 mm<sup>2</sup>.
- Push the cable through the cap nut, compression part and basic part of the cable gland.
- Insert the cable into the housing of the transmitter.
- Screw the sealing ring side of the basic part into the transmitter housing.
- Fix the cable gland by screwing the cap nut onto the basic part.
- Connect the cable to the terminals of the transmitter.



Fig. 7.15: Cable gland for aluminum housing



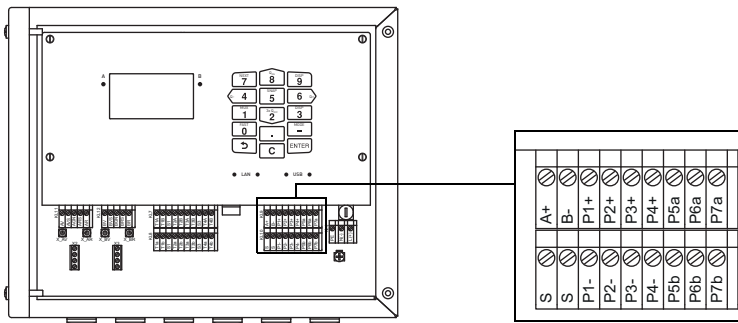
- 1 – cap nut
- 2 – compression part
- 3 – basic part

### 7.3 Outputs

**Important!**  
The max. permissible voltage between the outputs and against PE is 60 V DC (permanent).

- Connect the output cable to the transmitter (see 7.2.1, Fig. 7.16 and Tab. 7.11).

Fig. 7.16: Connection of the outputs to the transmitter




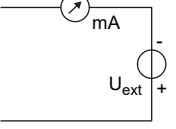

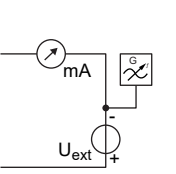
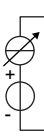
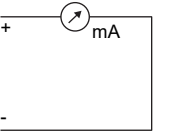

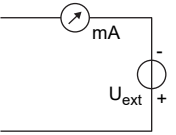

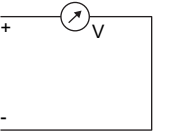

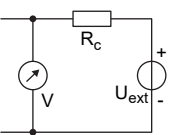
Tab. 7.11: Output circuits

output	transmitter		external circuit	explanation
	internal circuit	connection		
active current output/HART	current output			
		Px+  Px-		$U_{int} = 24\text{ V}$ $R_{ext} < 500\ \Omega$
	HART			
		Px+  Px-		$U_{int} = 24\text{ V}$ $R_{ext} < 500\ \Omega$

The number, type and connections of the outputs depend on the order.

$R_{ext}$  is the sum of all ohmic resistances in the circuit (e.g., resistance of the conductors, resistance of the ammeter/voltmeter).

Tab. 7.11: Output circuits

output	transmitter		external circuit	explanation
	internal circuit	connection		
passive current output/HART	current output			
		Px+  Px-		$U_{ext} = 8 \dots 30 \text{ V}$ $U_{ext} > 0.024 \text{ A} \cdot R_{ext} [\Omega] + 8 \text{ V}$ example: $U_{ext} = 30 \text{ V}$ $R_{ext} \leq 900 \Omega$
switchable current output	HART			
		Px+  Px-		$U_{ext} = 10 \dots 24 \text{ V}$
All switchable current outputs are jointly switched to active or passive in the menu item Special functions \ Outputs.	active current output			
		Px+  Px-		$U_{int} = 15 \text{ V}$ $R_{ext} < 250 \Omega$
voltage output	passive current output			
		Px+  Px-		$U_{ext} = 8 \dots 30 \text{ V}$ $U_{ext} > 0.024 \text{ A} \cdot R_{ext} [\Omega] + 8 \text{ V}$ example: $U_{ext} = 30 \text{ V}$ $R_{ext} \leq 900 \Omega$
frequency output TF7- *721**_*****_*****a-*****_** a = U, V, D	active current output			
		Px+  Px-		$R_{int} = 500 \Omega$ $R_{ext} > 2 \text{ M}\Omega$ If $R_{ext}$ is smaller, the accuracy is less than specified.
frequency output TF7- *721**_*****_*****a-*****_** a = U, V, D	passive current output			
		Px+  Px-		$U_{ext} = 5 \dots 24 \text{ V}$ $R_c [\text{k}\Omega] = U_{ext} / I_c [\text{mA}]$ $I_c = 1 \dots 4 \text{ mA}$ $R_{int} = 66.5 \Omega$

The number, type and connections of the outputs depend on the order.

$R_{ext}$  is the sum of all ohmic resistances in the circuit (e.g., resistance of the conductors, resistance of the ammeter/voltmeter).

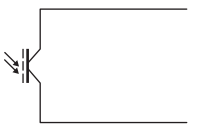
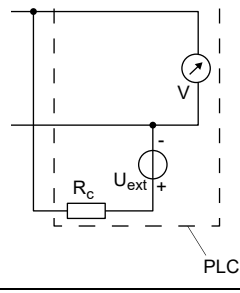

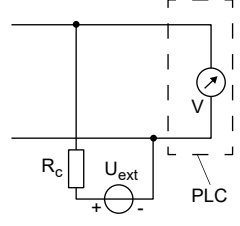
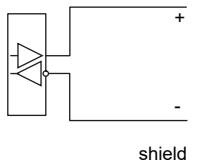
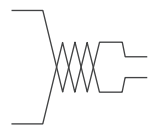
Tab. 7.11: Output circuits

output	transmitter		external circuit	explanation
	internal circuit	connection		
binary output (optorelay) TF7- *721**_*****_*****a-*****_** a = U, V, D	circuit 1			$U_{ext} \leq 26 \text{ V}$ $I_c \leq 100 \text{ mA}$ $R_c [\text{k}\Omega] = U_{ext} / I_c [\text{mA}]$
		Pxa		
		Pxb		
	circuit 2			
	Pxa			
	Pxb			
binary output (Reed relay) (*721)	circuit 1			$U_{max} = 48 \text{ V}$ $I_{max} = 100 \text{ mA}$ P1...P4: $R_{int} = 22 \Omega$ $R_c [\text{k}\Omega] = U_{ext} / I_{max} [\text{mA}] - R_{int}$
		Px+/Pxa		
		Px-/Pxb		
	circuit 2			
	Px+/Pxa			
	Px-/Pxb			

The number, type and connections of the outputs depend on the order.

$R_{ext}$  is the sum of all ohmic resistances in the circuit (e.g., resistance of the conductors, resistance of the ammeter/voltmeter).

Tab. 7.11: Output circuits

output	transmitter		external circuit	explanation
	internal circuit	connection		
digital output TF7- *72***_*****_*****a-*****_** a = M, P, Q	circuit 1			$U_{ext} = 5 \dots 30 \text{ V}$ $I_c < 100 \text{ mA}$ $R_c [\text{k}\Omega] = U_{ext} / I_c [\text{mA}]$
		Pxa  Pxb		
circuit 2				
	Pxa  Pxb			
RS485		A+  B- S		120 $\Omega$ termination resistor

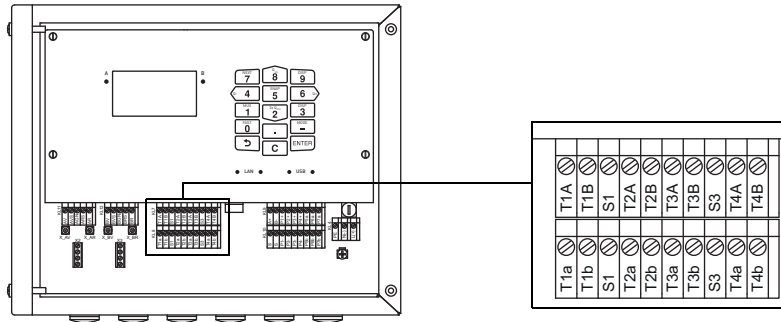
The number, type and connections of the outputs depend on the order.

$R_{ext}$  is the sum of all ohmic resistances in the circuit (e.g., resistance of the conductors, resistance of the ammeter/voltmeter).

## 7.4 Inputs

<b>Important!</b>
The max. permissible voltage between the inputs and against PE is 60 V DC (permanent).

Fig. 7.17: Connection of the inputs to the transmitter



### 7.4.1 Current input

An active (self-powered) or a passive (external powered) current source can be connected to the current inputs of the transmitter.

#### Connection of an active current source

<b>Important!</b>
The terminals Txa and Txb must not be connected.

For the connection of the input cable to the transmitter see section 7.2.1, Fig. 7.17 and Tab. 7.12.

Tab. 7.12: Connection of an active current source

input	transmitter		external circuit	remark
	internal circuit	connection		
current input		TxA TxB Txb (not connected)		max. permanent overcurrent: 100 mA

If the polarity of the current source is inverted, only the sign of the measured current will change.

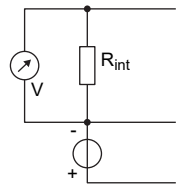
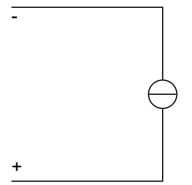
**Connection of a passive current source**

**Important!**  
 The terminals Txa and TxB must not be connected.

**Important!**  
 Observe the correct polarity in order to avoid damaging the current source. A permanent short circuit can lead to the destruction of the current input.

For the connection of the input cable to the transmitter see section 7.2.1, Fig. 7.17 and Tab. 7.13.

Tab. 7.13: Connection of a passive current source

input	transmitter		external circuit	remark
	internal circuit	connection		
current input		TxA  TxB (not connected)  Txb		max. permanent overcurrent: 100 mA

At full load (20 mA), a voltage of 22.9 V DC is available for the supply of the passive current source.

**7.4.2 Binary input**

The transmitter can be equipped with max. 4 binary inputs. Binary inputs can process measured values with short pulse. Via the binary inputs, it is possible to remotely trigger some functions of the transmitter. For the connection of the input cable to the transmitter, see section 7.2.1, Fig. 7.16 and Tab. 7.14.

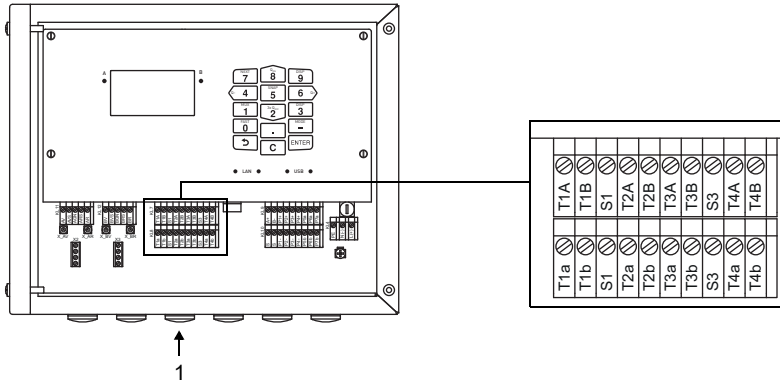
Tab. 7.14: Connection of the binary inputs

binary input	terminal
S1	Px+, Px-
S2	Px+, Px-
S3	Px+, Px-
S4	Px+, Px-

### 7.5 Temperature probe

It is possible to connect the temperature probes Pt100/Pt1000 (4-wire) to the inputs of the transmitter (optional).

Fig. 7.18: Connection of the temperature probes to the transmitter



1 – connection of the temperature probe

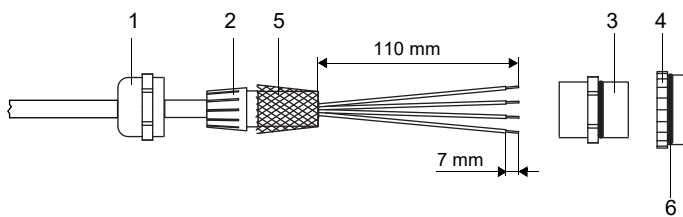
Tab. 7.15: Connection systems

direct connection	connection with extension cable	connection with junction box
<p>transmitter</p> <p>temperature probe</p>	<p>transmitter</p> <p>transmitter</p> <p>extension cable</p> <p>extension cable</p> <p>temperature probe</p> <p>temperature probe</p>	<p>transmitter</p> <p>extension cable</p> <p>temperature probe</p>

### 7.5.1 Direct connection of the temperature probe

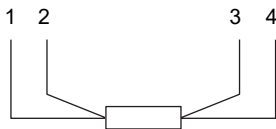
- Remove the blind plug for the connection of the temperature probe.
- Open the cable gland of the temperature probe. The compression part remains in the cap nut.
- Push the cable of the temperature probe through the cap nut, the compression part, the basic part and the reducer.
- Prepare the cable.
- Shorten the external shield and brush it back over the compression part.
- Insert the cable into the housing.
- Screw the sealing ring side of the reducer into the transmitter housing.
- Screw the basic part into the reducer.
- Fix the cable gland by screwing the cap nut onto the basic part.
- Connect the temperature probe to the terminals of the transmitter.

Fig. 7.19: Preparation of the temperature probe



- 1 – cap nut
- 2 – compression part
- 3 – basic part
- 4 – reducer
- 5 – external shield, brushed back
- 6 – sealing ring side

Fig. 7.20: Temperature probe



- 1 – red
- 2 – red/blue
- 3 – white/blue
- 4 – white

Tab. 7.16: Terminal assignment (transmitter)

terminal	temperature probe
T1a...T4a	red
T1A...T4A	red/blue
T1b...T4b	white/blue
T1B...T4B	white



### 7.5.2 Connection with extension cable

- Remove the blind plug for the connection of the temperature probe.
- Open the cable gland of the extension cable. The compression part remains in the cap nut.
- Push the extension cable through the cap nut, the compression part, the basic part and the reducer.
- Prepare the extension cable.
- Shorten the external shield and brush it back over the compression part.
- Insert the extension cable into the housing.
- Screw the sealing ring side of the reducer into the transmitter housing.
- Screw the basic part into the reducer.
- Fix the cable gland by screwing the cap nut onto the basic part.
- Connect the connectors of the extension cable and the temperature probe.
- Connect the extension cable to the terminals of the transmitter.

Tab. 7.17: Terminal assignment (transmitter)

terminal	extension cable
T1a...T4a	red
T1A...T4A	gray
T1b...T4b	blue
T1B...T4B	white

### 7.5.3 Connection with junction box

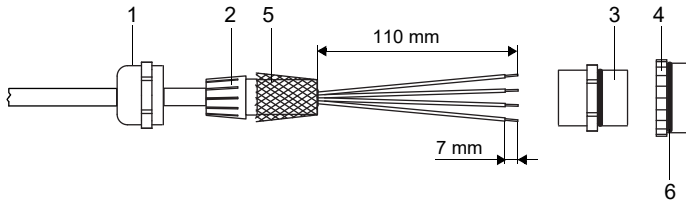
#### Connection of the extension cable to the transmitter

- Remove the blind plug for the connection of the temperature probe.
- Open the cable gland of the extension cable. The compression part remains in the cap nut.
- Push the extension cable through the cap nut, the compression part, the basic part and the reducer.
- Prepare the extension cable.
- Shorten the external shield and brush it back over the compression part.
- Insert the extension cable into the housing.
- Screw the sealing ring side of the reducer into the transmitter housing.
- Screw the basic part into the reducer.
- Fix the cable gland by screwing the cap nut onto the basic part.
- Connect the extension cable to the terminals of the transmitter.

#### Connection of the extension cable to the junction box

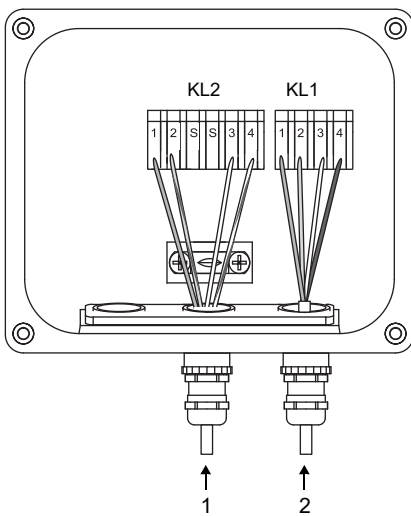
- Remove the blind plug for the connection of the extension cable.
- Open the cable gland of the extension cable. The compression part remains in the cap nut.
- Push the extension cable through the cap nut and the compression part.
- Prepare the extension cable.
- Shorten the external shield and brush it back over the compression part.
- Screw the sealing ring side of the reducer into the junction box.
- Screw the basic part into the reducer.
- Insert the extension cable into the junction box.
- Fix the cable gland by screwing the cap nut onto the basic part.
- Connect the extension cable to the terminals of the junction box.

Fig. 7.21: Preparation of the extension cable



- 1 – cap nut
- 2 – compression part
- 3 – basic part
- 4 – reducer
- 5 – external shield, brushed back
- 6 – sealing ring side

Fig. 7.22: Junction box



- 1 – connection of the extension cable
- 2 – connection of the temperature probe

**Connection of the temperature probe to the junction box**

- Remove the blind plug for the connection of the temperature probe.
- Open the cable gland of the temperature probe. The compression part remains in the cap nut.
- Push the cable of the temperature probe through the cap nut and the compression part.
- Prepare the cable.
- Shorten the external shield and brush it back over the compression part.
- Screw the sealing ring side of the reducer into the junction box.
- Screw the basic part into the reducer.
- Insert the cable into the junction box.
- Fix the cable gland by screwing the cap nut onto the basic part.
- Connect the temperature probe to the terminals of the junction box.

Tab. 7.18: Terminal assignment (junction box)

terminal	extension cable (KL2)	temperature probe (KL1)
1	red	red
2	gray	red/blue
3	blue	white/blue
4	white	white

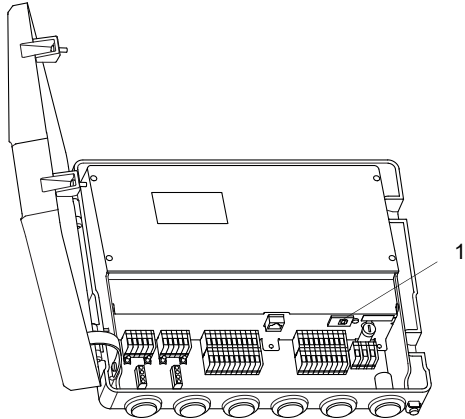
## 7.6 Service interfaces

### 7.6.1 USB interface

The transmitter can be connected directly to the PC via the USB interface.

- Connect the USB cable to the USB interface of the transmitter and to the PC.

Fig. 7.23: Connection of the USB cable



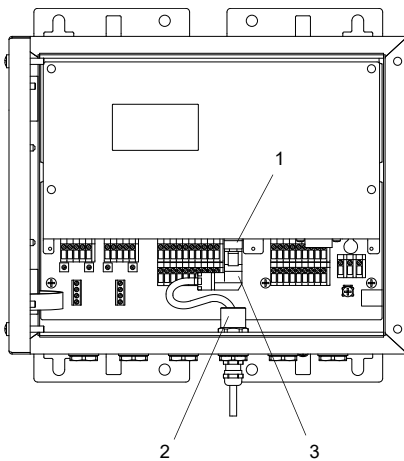
1 – USB interface

### 7.6.2 LAN interface

The transmitter can be connected to the PC or LAN via a LAN cable.

#### Transmitter with stainless steel housing

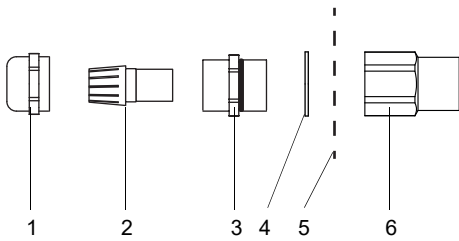
Fig. 7.24: Connection of the LAN cable



1 – LAN interface  
2 – ferrite nut  
3 – LAN connector

- Remove the blind plug to connect the cable to the transmitter.
- Open the cable gland of the LAN cable. The compression part remains in the cap nut.

Fig. 7.25: Cable gland

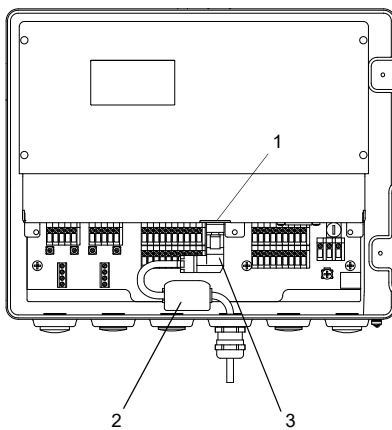


- 1 – cap nut
- 2 – compression part
- 3 – basic part
- 4 – sealing ring (only for cable gland M20, not for cable gland 1/2 NPS)
- 5 – housing wall
- 6 – ferrite nut

- Push the cable through cap nut, compression part, basic part and sealing ring (sealing ring: only for cable gland M20, not for cable gland 1/2 NPS).
- Insert the cable into the housing of the transmitter.
- Push the cable through the ferrite nut.
- Prepare the cable (see the documentation provided by the manufacturer).
- Install the connector (see the documentation provided by the manufacturer).
- Insert the connector into the LAN interface.
- Position the cable in the housing as shown in Fig. 7.24.
- Fix the cable gland by screwing the cap nut onto the basic part.
- Fix the transducer cable by tightening the cable gland with the ferrite nut.

### Transmitter with aluminum housing

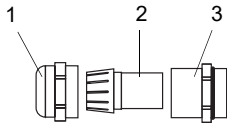
Fig. 7.26: Connection of the LAN cable



- 1 – LAN interface
- 2 – foldable ferrite core
- 3 – LAN connector

- Remove the blind plug to connect the cable to the transmitter.
- Open the cable gland of the LAN cable. The compression part remains in the cap nut.

Fig. 7.27: Cable gland



- 1 – cap nut
- 2 – compression part
- 3 – basic part

- Push the cable through the cap nut, compression part and basic part of the cable gland.
- Insert the cable into the housing of the transmitter.
- Prepare the cable (see the documentation provided by the manufacturer).
- Install the connector (see the documentation provided by the manufacturer).
- Insert the connector into the LAN interface.
- Fix the foldable ferrite core to the cable.
- Position the cable in the housing as shown in Fig. 7.26.
- Screw the sealing ring side of the basic part into the transmitter housing.
- Fix the cable gland by screwing the cap nut onto the basic part.

## 8 Start-up

### Danger!



#### **Risk of explosion when using the measuring equipment in explosive atmospheres (ATEX, IECEx)**

This may result in personal or material damage or dangerous situations.

→ Observe the "Safety instructions for the use in explosive atmospheres" (see document SIFLUXUS).

### Danger!



#### **Risk of explosion when using the measuring equipment in explosive atmospheres (TR TS)**

This may result in personal or material damage or dangerous situations.

→ Observe the "Safety instructions for the use in explosive atmospheres" (see document SIFLUXUSRU).

### Warning!



#### **Installation, connection and start-up by unauthorized and unqualified personnel**

This may result in personal or material damage or dangerous situations.

→ Any work on the transmitter has to be carried out by authorized and qualified personnel.

### Danger!



#### **Working in mines or cramped confines**

Risk of intoxication and/or asphyxiation because of emerging gases, risk of injuries because of cramped conditions.

→ Wear the required personal protective equipment.

→ Observe the applicable rules.

### Caution!



#### **Safety and accident prevention regulations for electrical systems and equipment**

Failure to observe these regulations may lead to severe injuries.

→ Observe the safety and accident prevention regulations for electrical systems and equipment.

### Caution!



#### **Warning of severe injuries from hot or cold components**

Touching hot or cold components can lead to severe injuries (e.g., thermal damage).

→ Any mounting, installation or connection work has to be concluded.

→ Any work on the measuring point during the measurement is prohibited.

→ Observe the ambient conditions at the measuring point during installation.

→ Wear the required personal protective equipment.

→ Observe the applicable rules.

### Notice!

The transmitter and transducers have to be checked to ensure proper condition and operational safety before each use. The transmitter housing must always be closed during operation. Observe that maintenance work must be concluded.

## 8.1 Start-up settings

When starting up the transmitter for the first time, the following settings are required:

- language
- time/date
- unit of measurement

These displays will only be indicated when the transmitter is switched on for the first time or after an initialization.

### Language

The available transmitter languages are displayed.

- Select a language.
- Press ENTER.

The menus are displayed in the selected language.

### Set time

The current time is displayed.

- Press ENTER to confirm the time or set the current time via the numeric field.
- Press ENTER.

### Set date

The current date is displayed.

- Press ENTER to confirm the date or set the current date via the numeric field.
- Press ENTER.

### Units of measurement

- Select `Metric` or `Imperial`.
- Press ENTER.

### Region of Canada

- Select `Yes` if the transmitter is to be used in the region of Canada.
- Press ENTER.

This display will only be indicated if `Imperial` is selected.


## 8.2 Switching on

As soon as the transmitter is connected to the power supply, the menu is displayed in the adjusted language. The language can be changed.

### Notice!

The parameters cannot be changed during the measurement. The measurement has to be stopped in order to change the parameters.

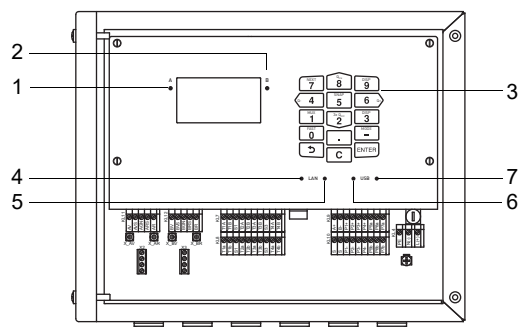
If the transmitter was switched off during the measurement, the message `Measurement started` will be displayed after connecting the transmitter to the power supply. The measurement is carried out with the parameters last set.

By pressing  in the program branch `Measurement` it is possible either to stop the measurement or to display the current parameter settings.

### 8.3 Status indications

The operation state is indicated by LEDs.

Fig. 8.1: Command panel of the transmitter



- 1 – LED (channel A)
- 2 – LED (channel B)
- 3 – keyboard
- 4 – LED LAN activity
- 5 – LED LAN mode
- 6 – LED USB device
- 7 – LED USB host (not used)

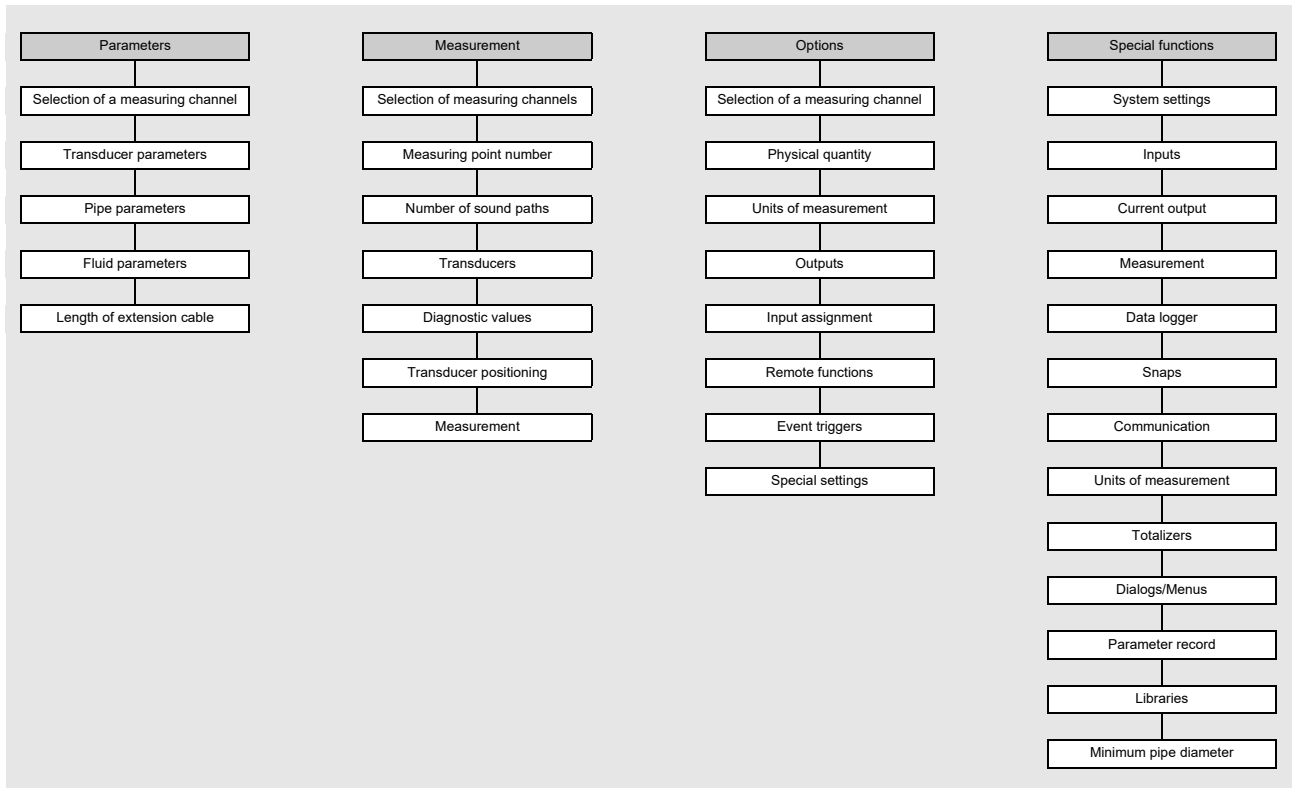
Tab. 8.1: Operation state of the transmitter

LED (channel A)	Lights if the transmitter is in measuring mode and channel A is activated. red – invalid measurement green – valid measurement
LED (channel B)	Lights if the transmitter is in measuring mode and channel B is activated. red – invalid measurement green – valid measurement
LED LAN activity	Lights if the transmitter is connected to a network via USB cable. Flashes in case of data exchange on the network connection.
LED LAN mode	Lights if the data rate is 100 MBit/s otherwise it is 10 MBit/s.
LED USB device	Lights if the transmitter is connected to a PC via USB cable. Flashes in case of data exchange between PC and transmitter.



## 8.4 Program branches

The following schema shows the program branches. For a detailed overview of the menu structure see annex A.



## 8.5 Language

Special functions\System settings\Language

The language of the transmitter can be selected:

- Select the menu item `Language`.
- Press ENTER.
- Select the desired language from the scroll list.
- Press ENTER.




Afterwards the menu will be displayed in the selected language. The selected language remains activated when the transmitter is switched off and on again.

The language can also be changed by entering a HotCode.

## 8.6 Initialization

During an initialization (INIT) of the transmitter, all settings are reset to the factory settings.

Proceed as follows to execute an initialization:

- When switching on a transmitter: keep  and C pressed.
- During the operation of the transmitter: press , C and ENTER simultaneously. Release only ENTER. Keep  and C pressed.

During an initialization it is tested whether the key lock is activated. If so, it has to be deactivated.

- Enter a 6-digit key lock code.
- Press ENTER.

If a measurement is currently running, it will be stopped.

It will be requested whether the initial settings are to be carried out.

Initial settings

If Yes is selected, the following setting dialogs will be displayed.

- Language
- Date/time
- Units of measurement
- Delete meas. values
- Delete snaps
- Delete user subst. (all customized materials and fluids which were stored after delivery will be deleted)
- Reset totalizers

The initialization can also be started with the HotCode **909000**.

## 8.7 Date and time

Special functions\System settings>Date/time

The transmitter has a battery-powered clock. Measured values are automatically stored with date and time.

- Select the menu item Date/time.

The adjusted time is displayed.




- Enter the current time.
- Press ENTER.

The adjusted date is displayed.

- Enter the current date.
- Press ENTER.

## 8.8 Information regarding the transmitter

Special functions\System settings\Transmitter info

- Select the menu item Transmitter info.
- Press ENTER.
- Press  or  to scroll through the list.
- Press  to return to the menu item System settings.

The following information relating to the transmitter is displayed:

display	description
Product name	designation of the transmitter
Serial number	serial number of the transmitter
Firmware version	version number of the installed firmware
Firmware date	creation date of the installed firmware
Production date	manufacturing date of the transmitter
MAC address	MAC address of the transmitter
Service TCP port	TCP port of the transmitter
Verification log	state of the verification logger

## 9 Measurement

### Danger!

**Risk of explosion when using the measuring equipment in explosive atmospheres (ATEX, IECEx)**

This may result in personal or material damage or dangerous situations.

→ Observe the "Safety instructions for the use in explosive atmospheres" (see document SIFLUXUS).

### Danger!

**Risk of explosion when using the measuring equipment in explosive atmospheres (TR TS)**

This may result in personal or material damage or dangerous situations.

→ Observe the "Safety instructions for the use in explosive atmospheres" (see document SIFLUXUSRU).

### Caution!

**Warning of severe injuries from hot or cold components**

Touching hot or cold components can lead to severe injuries (e.g., thermal damage).

→ Any mounting, installation or connection work has to be concluded.

→ Any work on the measuring point during the measurement is prohibited.

→ Observe the ambient conditions at the measuring point during installation.

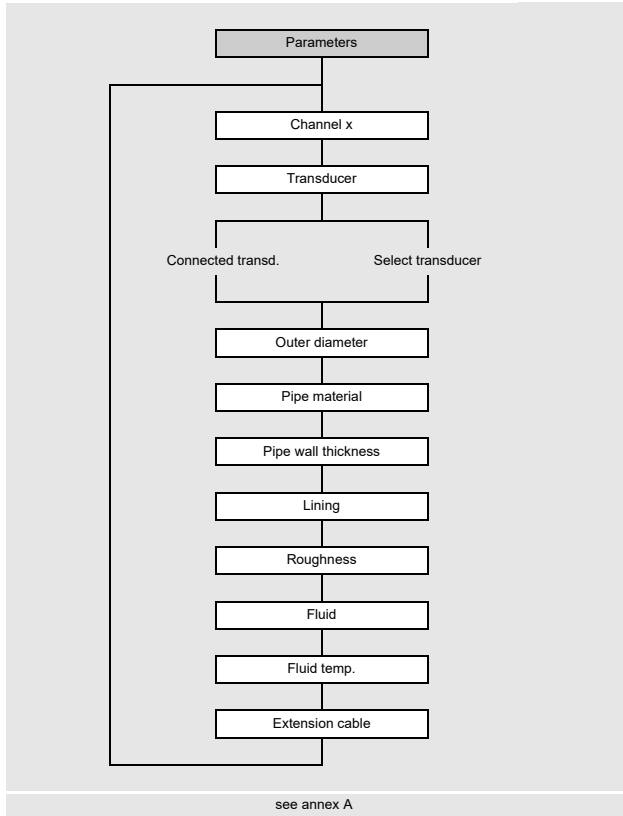
→ Wear the required personal protective equipment.

→ Observe the applicable rules.

## 9.1 Parameter input

### Notice!

Avoid a simultaneous parameter entry via the keyboard and the USB, LAN or process interface. The parameter records received via these interfaces will overwrite the current transmitter parameterization.



The pipe and fluid parameters are entered for the selected measuring point. The parameter ranges are limited by the technical characteristics of the transducers and the transmitter.

- Select the program branch `Parameters`.
- Press ENTER.

```
Parameters\Channel A
```

- Select the channel for which the parameters are to be entered (here: `Channel A`).
- Press ENTER.

The display will not be indicated if the transmitter has only one measuring channel.

FLUXUS \*722:

If the synchronized channel averaging is activated in the menu item `Special functions\Measurement\Measurement modes\Synch. chan. averag.`, the measuring channels A and B are not separately parameterized (display: `Channel AB`).

### 9.1.1 Transducer selection

#### Notice!

The transducers have to be selected depending on the application parameters (see technical specification).

```
Parameters\Clamp-on transducer CDP2E52
```

- The transducer (here: `CDP2E52`) connected to the transmitter is displayed.
  - Press ENTER.
- The display will only be indicated if a `SENSPROM` is connected to the transmitter.

```
Parameters\Connected transd.
```

The parameters can also be entered without connected transducers or `SENSPROM`.

- Select the list item `Connected transd.`
- Press ENTER.

The display `Transducer not found` will be indicated if neither transducers nor `SENSPROM` are connected.

- Press ENTER.

```
Parameters>Select transducer
```

- Select the list item `Select transducer` to use standard transducers stored in the transmitter.
- Select the transducer.
- Press ENTER.

This display will not be indicated if the transducers and the `SENSPROM` are connected to the transmitter.

**Notice!**

If a standard transducer is selected, no transducer-specific calibration values are considered. A higher uncertainty has to be expected.

**9.1.2 Input of pipe parameters****Outer pipe diameter**

Parameters\Outer diameter

- Enter the outer pipe diameter.
- Press ENTER.

It is possible to enter the pipe circumference instead of the outer pipe diameter.

**Pipe circumference**

Parameters\Pipe circumference

- Activate the input of the pipe circumference in the menu item `Special functions\Dialogs/Menus\Pipe circumference`.
- Press  in the menu item `Outer diameter`. The menu item `Pipe circumference` will be displayed.
- Enter the pipe circumference.
- Press ENTER.

If the outer pipe diameter is to be entered, press . The menu item `Outer diameter` is displayed.

**Pipe material**

Parameters\Pipe material

The pipe material has to be selected to be able to determine the corresponding sound speed.

The sound speeds for the materials in the scroll list are stored in the transmitter.

- Select the pipe material.
- If the material is not in the scroll list, select the list item `Other material`.
- Press ENTER.

**Sound speed of the pipe material**

Parameters\Pipe material\Other material\c material

- Enter the sound speed of the pipe material.

**Notice!**

There are 2 sound speeds for pipe materials: the longitudinal and the transversal one. Enter the sound speed which is nearer to 2500 m/s.

- Press ENTER.
- Select `Transverse wave` or `Longitudinal wave`.
- Press ENTER.

These displays will only be indicated if `Other material` is selected.

For the sound speed of some materials see annex C.

## Roughness of the pipe material

Parameters\Pipe material\Other material\Roughness

The flow profile of the fluid is influenced by the roughness of the inner pipe wall.

The roughness is used for the calculation of the profile correction factor.

In most cases, the pipe roughness cannot be exactly determined and must therefore be estimated.

- Press ENTER if the pipe has a lining. The roughness of the lining is included into the calculation.
- Enter the roughness of the pipe material in case the pipe has no lining. Press ENTER.

This display will only be indicated if `Other material` is selected.

For the roughness of some materials see annex C.

## Wall thickness

Parameters\Pipe wall thickness

- Enter the pipe wall thickness.
- Press ENTER.

## Lining

Parameters\Lining

- Select `Yes` if the pipe has a lining. Select `No` if the pipe has no lining.
- Press ENTER.

## Lining material

Parameters\Lining material

- Select the lining material.
- Press ENTER.
- If the lining material is not included in the scroll list, select the list item `Other material`.
- Press ENTER.

This display will only be indicated if `Yes` is selected in the menu item `Lining`.

## Sound speed of the lining material

Parameters\Lining material\Other material\c material

- Enter the sound speed of the lining material.

### Notice!

For pipe materials there are 2 sound speeds, the longitudinal and the transversal one. Enter the sound speed which is nearer to 2500 m/s.

- Press ENTER.
- Select `Transverse wave` or `Longitudinal wave`.
- Press ENTER.

These displays will only be indicated if `Other material` is selected.

**Roughness of the lining material**

Parameters\Lining material\Other material\Roughness

The flow profile of the fluid is influenced by the roughness of the inner pipe wall.

The roughness is used for the calculation of the profile correction factor.

In most cases, the pipe roughness cannot be exactly determined and must therefore be estimated.

- Enter the roughness of the lining material.
- Press ENTER.

This display will only be indicated if `Other material` is selected.

**Lining thickness**

Parameters\Lining thickness

- Enter the thickness of the lining.
- Press ENTER.

This display will only be indicated if `Yes` is selected in the menu item `Lining`.

**Roughness**

Parameters\Roughness

The flow profile of the fluid is influenced by the roughness of the inner pipe wall.

The roughness is used for the calculation of the profile correction factor.

In most cases, the pipe roughness cannot be exactly determined and must therefore be estimated.

- If `Automatic` is selected, the roughness values stored in the transmitter are used.
- If `Customized` is selected, a roughness value has to be entered.
- Press ENTER.

This display will not be indicated if `Other material` is selected in the menu item `Pipe material` or `Lining material`.

**9.1.3 Input of fluid parameters****Fluid**

Parameters\Fluid

- Select the fluid from the scroll list.
- If the fluid is not in the scroll list, select the list item `Other fluid`.
- Press ENTER.

**Sound speed of the fluid**

Parameters\Fluid\Other fluid\c fluid

The sound speed of the fluid is used for the calculation of the transducer distance. The exact value of the sound speed is not always known. Therefore, a range of possible values for the sound speed has to be entered.

- Enter the average sound speed of the fluid.
- Press ENTER.

This display will only be indicated if `Other fluid` is selected.

### Sound speed range of the fluid

Parameters\Fluid\Other fluid\Range c fluid

- Select `Automatic` if the range around the average sound speed has to be set to  $\pm 10\%$  the entered sound speed.
- Select `Customized` if the range around the average sound speed has to be entered.

• Press ENTER.

This display will only be indicated if `Other fluid` is selected.

Parameters\Fluid\Other fluid\Range c fluid\Customized

- Enter the range around the average sound speed of the fluid.
- Press ENTER.

This display will only be indicated if `Customized` is selected.

### Kinematic viscosity of the fluid

Parameters\Fluid\Other fluid\Kin. viscosity

The kinematic viscosity influences the flow profile of the fluid. The value is considered in the profile correction.

- Enter the kinematic viscosity of the fluid.
- Press ENTER.

This display will only be indicated if `Other fluid` is selected.

### Fluid density

Parameters\Fluid\Other fluid\Fluid density

The density is used to calculate the mass flow.

If the mass flow is not measured, an input is unnecessary. The default value can be used.

- Enter the operating density of the fluid.
- Press ENTER.

This display will only be indicated if `Other fluid` is selected.

### Fluid temperature

Parameters\Fluid temp.

The fluid temperature is used:

- at the beginning of the measurement for the interpolation of the sound speed and therefore for the calculation of the recommended transducer distance
- during the measurement for the interpolation of the density and the viscosity of the fluid

This value is only used, if the fluid temperature is not measured. The value has to be within the ambient temperature of the transducers.

- In case of a temperature range, enter the average fluid temperature.

#### Notice!

If the relation between the sound speed and the temperature is not linear, see the sound speed-temperature curve.

- Press ENTER.



### Parameterization of a mixture with changing composition

If a mixture with changing composition has been selected, the variable proportion of the mixture has to be entered (see annex C.3.2).

- Enter the variable proportion of the mixture.
- Press ENTER.

#### 9.1.4 Other parameters

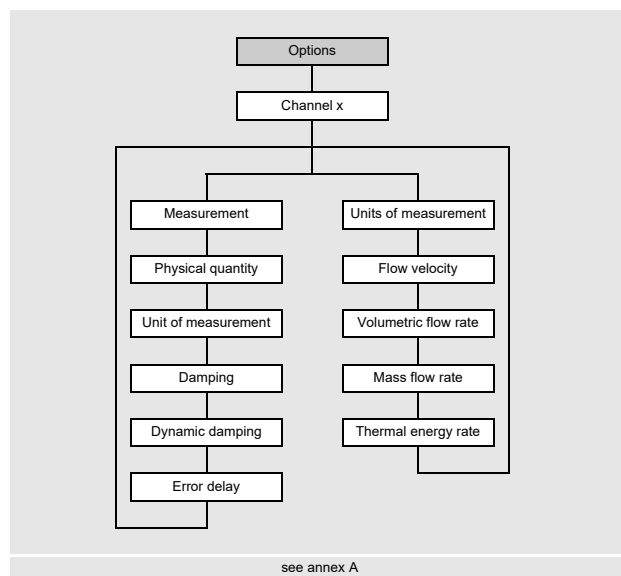
##### Extension cable

```
Parameters\Extension cable
```

In case the transducer cable is extended (e.g., between junction box and transmitter), enter the length of the extension cable.

- Select the menu item `Extension cable` in the program branch `Parameters`.
- Enter the length of the extension cable.
- Press ENTER.

## 9.2 Measurement settings



- Select the program branch `Options`.
- Press ENTER.

```
Options\Channel A
```

- Select the channel for which a physical quantity has to be entered (here: `Channel A`)
- Press ENTER.

This display will not be indicated if the transmitter has only one measuring channel.

- Select the menu item `Measurement`.
- Press ENTER.

### FLUXUS \*722:

If the synchronized channel averaging is activated in the menu item `Special functions\Measurement\Measurement modes\Synch. chan. averag.`, the measuring channels A and B are not separately parameterized (display: `Channel AB`).

#### 9.2.1 Selection of the physical quantity

```
Options\Channel A\Measurement\Physical quantity
```

The available physical quantities are displayed in a list.

- Select the physical quantity.
- Press ENTER.

#### 9.2.2 Selection of the unit of measurement

```
Options\...\Volumetric flow rate
```

For the selected physical quantity (except sound speed), a scroll list with the available units of measurement is displayed.

- Select the unit of measurement of the physical quantity.
- Press ENTER.

**Notice!**

If the physical quantity or the unit of measurement is changed, the settings of the outputs have to be checked.

### 9.2.3 Input of the damping factor

Options\...\Damping

Each displayed measured value is a floating average of the last x seconds, with x being the damping factor. If 0 s is entered as damping factor, no average is calculated.

The value of 10 s is appropriate for normal flow conditions. If the values fluctuate strongly, caused by a higher dynamic flow, a higher damping factor can be very useful.

- Enter the damping factor.
- Press ENTER.

FLUXUS \*722:

If the synchronized channel averaging is activated in the menu item `Special functions\Measurement\Measurement modes\Synch. chan. averag.`, this display will not be indicated for the channel AB. The damping factor is set to 0 s.

### 9.2.4 Dynamic damping

If dynamic damping is activated, volatile changes in the measured values of the selected physical quantity are transmitted through the transmitter without any time lag.

**Important!**

The dynamic damping will only have impact on the selected physical quantity. All other physical quantities are not dynamically damped.

Options\...\Dynamic damping

- Select **On** to activate the dynamic damping for the selected measuring channel.
- Press ENTER.

This display will only be indicated if dynamic damping has been activated in the menu item `Special functions\Measurement\Measurement settings\Dynamic damping`.

Options\...\Dynamic damping\Dynamic threshold

- Enter the value for the dynamic threshold for the particular measuring channel. If zero is entered, dynamic damping will be deactivated.
- Press ENTER.

Options\...\Dynamic damping\Transient damping

- Enter the damping factor for the temporary damping.
- Press ENTER.

**Notice!**

If another physical quantity is selected, the dynamic damping has to be entered again.

FLUXUS \*722:

If the synchronized channel averaging is activated in the menu item `Special functions\Measurement\Measurement modes\Synch. chan. averag.`, this display will not be indicated for the channel AB. Dynamic damping will be deactivated.


### 9.2.5 Input of the error delay

Options\...\Error delay

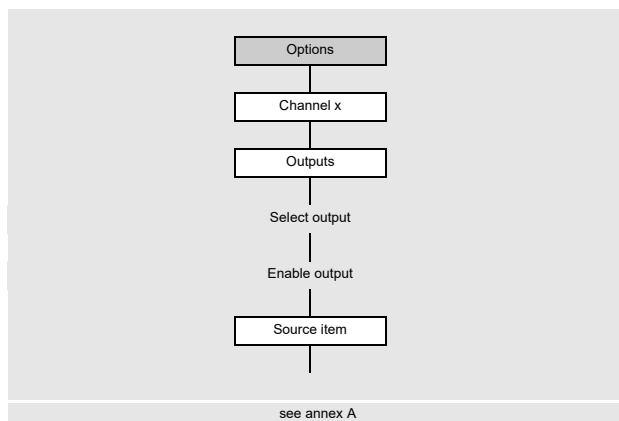
The error delay is the time interval after which the error value is transmitted to the output.

This display will only be indicated if the list item `Edit` is selected in the menu item `Special functions\Dialogs\Menus\Error delay`.

If no error delay is entered, the damping factor will be used.

- Enter a value for the error delay.
- Press ENTER.
- Press and hold  to return to the main menu.

### 9.2.6 Configuration of an output



If the transmitter is equipped with outputs, they have to be configured. The measured value, the status value or an event value can be transmitted via the different outputs. In the following, the configuration of an analog output is described.

- Select the program branch `Options`.
- Press ENTER.

#### Selection of the measuring channel

Options\Channel A

- Select the channel (here: `Channel A`).
- Press ENTER.

This display will not be indicated if the transmitter has only one measuring channel.

FLUXUS \*722:

If the synchronized channel averaging is activated in the menu item `Special functions\Measurement\Measurement modes\Synch. chan. averag.`, it is necessary to select a source channel (A or B) when configuring an output.

#### Assignment of an output

- Select the menu item `Outputs`.
- Press ENTER.

Options\Channel A\Outputs\Current I1(--)

- Select an output to be assigned to the channel (here: `Current I1(--)`).
- Press ENTER.

The scroll list contains all available outputs of the transmitter.

If the output has already been assigned to a channel, it is displayed as follows: `Current I1 (A)`.

Options\Channel A\Outputs\Current I1\I1 Enable

- Select `Yes` to change the settings for an already assigned output or to assign a new output.
- Select `No` to cancel the assignment and to return to the previous menu item.
- Press ENTER.

### Assignment of a source item

One source item has to be assigned to each selected output.

Options\Channel A\Outputs\...\Source item

- Select a source item whose measured value, status value or event value is to be transmitted via the output.
- Press ENTER.

Tab. 9.1: Configuration of the outputs

source item	list item	output
Flow quantities	Flow velocity	flow velocity
	Volumetric flow rate	volumetric flow rate
	Mass flow rate	mass flow rate
	Thermal energy rate	thermal energy rate
Totalizers	Volume (+)	totalizer for the volumetric flow rate in positive flow direction
	Volume (-)	totalizer for the volumetric flow rate in negative flow direction
	Volume ( $\Delta$ )	difference of the totalizers for the positive and negative flow direction
	Mass (+)	totalizer for the mass flow rate in positive flow direction
	Mass (-)	totalizer for the mass flow rate in negative flow direction
	Mass ( $\Delta$ )	difference of the totalizers for the positive and negative flow direction
	Thermal energy (+)	thermal energy totalizer for positive measured values of the thermal energy rate
	Thermal energy (-)	thermal energy totalizer for negative measured values of the thermal energy rate
Thermal energy ( $\Delta$ )	difference of the thermal energy totalizer	
Pulse	Pulse  V	pulse without considering the sign of the volumetric flow rate
	Pulse +V	pulse for positive measured values of the volumetric flow rate
	Pulse -V	pulse for negative measured values of the volumetric flow rate
	Pulse  m	pulse without considering the sign of the mass flow rate
	Pulse +m	pulse for the positive measured values of the mass flow rate
	Pulse -m	pulse for the negative measured values of the mass flow rate
	Pulse  E	pulse without sign consideration of the thermal energy rate
	Pulse +E	pulse for positive measured values of the thermal energy rate
	Pulse -E	pulse for negative measured values of the thermal energy rate

Tab. 9.1: Configuration of the outputs

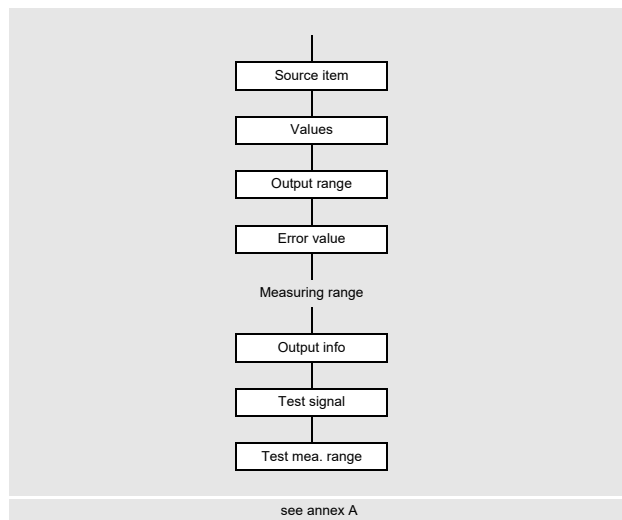
source item	list item	output
Fluid properties	Fluid temp.	fluid temperature
	Supply temperature	supply temperature (thermal energy rate measurement)
	Return temperature	return temperature (thermal energy rate measurement)
	Temperature ( $\Delta$ )	difference between supply and return temperature (thermal energy rate measurement)
	Fluid pressure	fluid pressure
	Supply pressure	supply pressure (thermal energy rate measurement)
	Return pressure	return pressure (thermal energy rate measurement)
	Pressure ( $\Delta$ )	difference between supply and return pressure (thermal energy rate measurement)
	Fluid density	fluid density
	Kin. viscosity	kinematic viscosity
Dyn. viscosity	dynamic viscosity	
Event trigger	R1	limit message (Event trigger R1)
	R2	limit message (Event trigger R2)
	R3	limit message (Event trigger R3)
	R4	limit message (Event trigger R4)
Diagnostic values	Amplitude	signal amplitude
	Quality	signal quality
	SNR	signal-to-noise ratio
	SCNR	signal-to-correlated noise ratio
	VariAmp	amplitude variation
	VariTime	transit time variation
	Amplification	amplification required to receive a useful signal
Pig detection	signalizes whether a pig is detected This display will only be indicated if Pig detection is activated.	
Miscellaneous	Custom. Input 1	measured values of input quantities (e.g., temperature, density) which are not used for calculation  In the menu item Options\Assign inputs it is possible to assign configured inputs to customized inputs.
	Custom. Input 2	
	Custom. Input 3	
	Custom. Input 4	
Sound speed	Sound speed	sound speed
	Sound speed ( $\Delta$ )	difference of the measured sound speed and the sound speed calculated from the fluid data

Depending on the selected source item, it is possible to output measured values, status values or event values.

Tab. 9.2: Output of measured values, status values or event values

	source item	measured value		event value
		value	status	
physical quantities	Flow quantities	x	x	
	Totalizers	x	x	
	Fluid properties	x	x	
	Miscellaneous (Custom. Input 1...4)	x	x	
	Sound speed	x	x	
	Pulse	x	x	
	Diagnostic values (except Pig detection)	x		
events	Diagnostic values\ Pig detection			x
	Event trigger			x

### 9.2.6.1 Output of a measured value



- Select the list item `Options\Outputs\...\Values`.
- Press ENTER.

#### Output range

```
Options\Channel A\Outputs\...\Output range
```

- Select a list item.
  - 4...20 mA
  - Other range

- Press ENTER.

If `Other range` is selected, enter the values `Output MIN` and `Output MAX`.

The output range has to be > 10 % of the max. output value (`Output MAX`). If the output range is smaller, an error message will be displayed.

#### Error output

```
Options\Channel A\Outputs\...\Error value
```

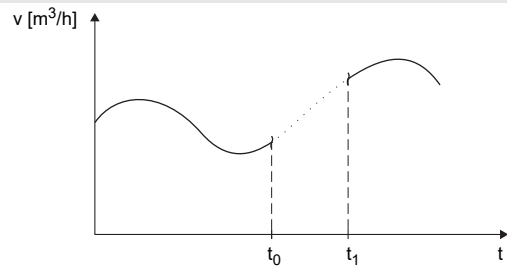
An error value can be defined which is output if the source item cannot be measured.

- Select a list item for the error output.
- Press ENTER.
- If `Other value` is selected, an error value has to be entered. The value has to be outside the output range. If the entered value is not valid, an error message and the permissible range will be displayed.
- Press ENTER.

**Example**

source item: volumetric flow rate  
 output: current output  
 output range: 4...20 mA  
 error delay:  $t_d > 0$

The volumetric flow rate cannot be measured during the time interval  $t_0...t_1$ . The error value will be output.



Tab. 9.3: Examples for the error output (output range: 4...20 mA)

list item	output signal
4.0 mA	
Last value	
20.0 mA	
Other value error value = 3.5 mA	

## Measuring range

The sign of the measured value and the measuring range are determined.

```
Options\Channel A\Outputs\...\Measured values\Absolute value
```

- Select `Sign` if the sign of the measured values is to be considered for the output.
- Select `Absolute value` if the sign of the measured values is not to be considered for the output.

```
Options\Channel A\Outputs\...\Start of meas. range
```

- Enter the lowest expected measured value. The unit of measurement of the source item will be displayed.  
`Start of meas. range` is the value assigned to the value `Output MIN` of the output range.

```
Options\Channel A\Outputs\...\End of meas. range
```

- Enter the highest expected measured value. The unit of measurement of the source item will be displayed.  
`End of meas. range` is the value assigned to the value `Output MAX` of the output range.

## Terminal assignment

```
Options\Channel A\Outputs\...\Output info
```

The terminals for the connection of the output are displayed.

By pressing `2` or `8` further information is displayed.

- Press ENTER.

## Output function test

The function of the output can now be tested.

- Connect an external measuring instrument to the terminals of the output.

```
Options\Channel A\Outputs\...\Test signal
```

- Select `Yes` to test the output. Select `No` to display the next menu item.
- Press ENTER.

```
Options\Channel A\Outputs\...\Enter test value
```

- Enter a test value. It has to be within the output range.
- Press ENTER.

If the external measuring instrument displays the entered value, the output functions correctly.

- Select `Repeat` to repeat the test, `Finish` to display the next menu item.
- Press ENTER.

```
Options\Channel A\Outputs\...\Test mea. range
```

- Select `Yes` to test the assignment of the measured value to the output signal. Select `No` to display the next menu item.
- Press ENTER.



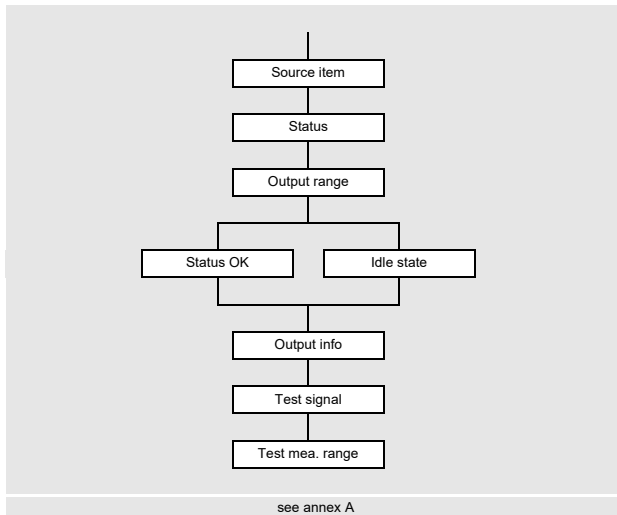
Options\Channel A\Outputs\...\Enter test value

- Select in the scroll list `Active` or `Passive`.
- Press `ENTER`.

If the external measuring instrument displays the value (min. output value for `Passive`, max. output for `Active`), the output functions correctly.

- Select `Repeat` to repeat the test. Select `Finish` to display the next menu item.
- Press `ENTER`.

### 9.2.6.2 Output of a status/event value



- Select the list item  
Options\Channel A\Outputs\...\Status.
- Press `ENTER`.

#### Output range

Options\Channel A\Outputs\...\Output range

- Select a list item.
    - 4...20 mA
    - Other range
  - Press `ENTER`.
- If `Other range` is selected, enter the values `Output MIN` and `Output MAX`.

The output range has to be > 10 % of the max. output value (`Output MAX`). If the output range is smaller, an error message will be displayed. The next possible value will be displayed.

status value – status OK	event value – idle state
The status of the output signal is defined which is to be output when measuring a measured value.	The status of the output signal is defined which is to be output if no event occurs.
<ul style="list-style-type: none"> <li>• Select the value for <code>Status OK</code> from the scroll list.</li> <li>• Press <code>ENTER</code>.</li> </ul>	<ul style="list-style-type: none"> <li>• Select the value for the idle state.</li> <li>• Press <code>ENTER</code>.</li> </ul>

### Terminal assignment

Options\Channel A\Outputs\...\Output info

The terminals for the connection of the output are displayed.

By pressing `2` or `8` further information is displayed.

- Press `ENTER`.

#### Output function test

The function of the output can now be tested.

- Connect an external measuring instrument to the terminals of the output.

Options\Channel A\Outputs\...\Test signal

- Select `Yes` to test the output. Select `No` to display the next menu item.
- Press `ENTER`.

Options\Channel A\Outputs\...\Enter test value

- Enter a test value. It has to be within the output range.
- Press ENTER.

If the external measuring instrument displays the entered value, the output functions correctly.

- Select Repeat to repeat the test, Finish to display the next menu item.
- Press ENTER.


Options\Channel A\Outputs\...\Test mea. range

- Select Yes to test the status of the output signal. Select No to display the next menu item.
- Press ENTER.

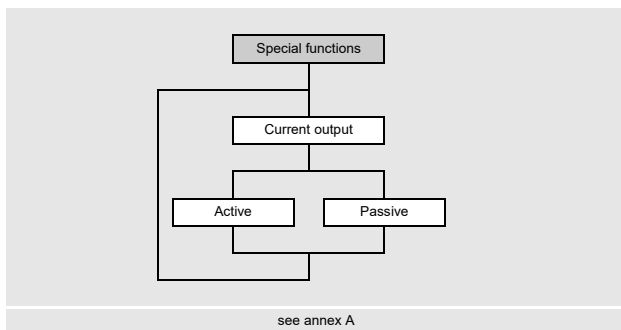
Options\Channel A\Outputs\...\Enter test value

- Select a list item as test value.
- Press ENTER.

status value	event value
Status OK or Status error If the external measuring instrument displays the value (min. output value for Status error, max. output for Status OK), the output functions correctly.	Active or Passive If the external measuring instrument displays the value (min. output value for Passive, max. output for Active), the output functions correctly.

- Select Repeat to repeat the test. Select Finish to display the next menu item.
- Press ENTER.
- Press and hold  to return to the main menu.

### 9.2.6.3 Switchable current outputs



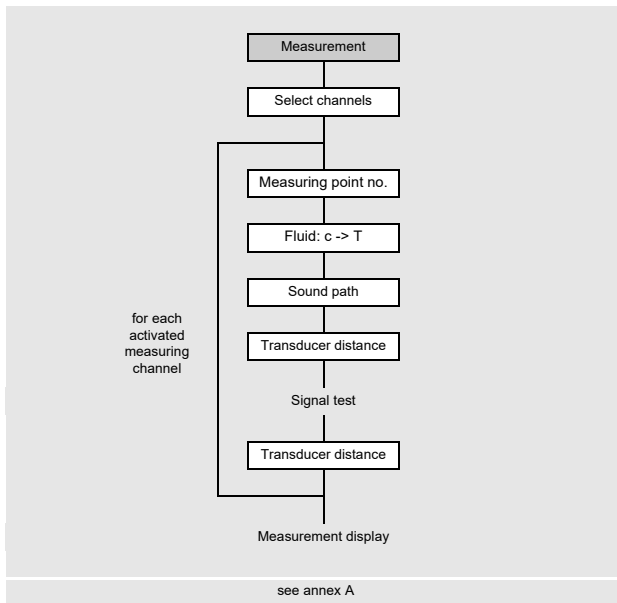
If the transmitter has switchable current outputs, it has to be defined how to switch them.

- Select the menu item Current output in the program branch Special functions.
- Press ENTER.

Special functions\Current output

- Select Active if the current outputs are to be switched to active.
  - Press ENTER.
- All switchable current outputs are switched to active.
- Select Passive if the current outputs are to be switched to passive.
  - Press ENTER.
- All switchable current outputs are switched to passive.

### 9.3 Start of the measurement



- Select the program branch `Measurement`.
- Press ENTER.

#### Activation of the channels

`Measurement\Select channels`

The channels for the measurement can be activated and deactivated.

: the channel is activated

: the channel is deactivated

: the channel cannot be activated

This display will not be indicated if the transmitter has only one measuring channel.

- Select a channel with `<4>` or `<6>`.

#### Notice!

Pass the program branch `Parameters` in its entirety if  is displayed for all channels.

- Press `<2>` or `<8>` to activate or deactivate the channel.

If the parameters in the program branch `Parameters` are not valid or incomplete, the error message `Invalid parameters` will be displayed.

A deactivated channel will be ignored during the measurement.

FLUXUS \*722:

If the synchronized channel averaging is activated in the menu item `Special functions\Measurement\Measurement modes\Synch. chan. averag.`, the measuring point number and the number of sound paths are queried once when the measurement is started. All other parameters are then queried individually for each measuring channel.

#### Input of the measuring point number

`Measurement\Measuring point no.`

- Enter the number of the measuring point.
- Press ENTER.

For the activation of text input see `Special functions\Dialogs/Menus\Measuring point no.`

#### Calibration of the temperature calculation from the sound speed

The transmitter is able to calculate the temperature from the sound speed of the fluid during the measurement. The accuracy of the measured sound speed of the fluid depends on the accuracy of the entered parameters or on the mounting of the transducers.

If the temperature has to be calculated from the sound speed of the fluid during the measurement, a calibration based on the actual fluid temperature is carried out when starting the measurement. It has to be measured and entered in the transmitter. From the difference of the entered fluid temperature and the sound speed of the calculated fluid temperature an offset is determined and stored in the transmitter.

If the measurement is started the first time with activated calculation of the fluid temperature from the sound speed, the transmitter does not have stored any offset yet. The fluid temperature has to be entered.

Measurement\Fluid temp.

- Enter the calculated fluid temperature.
- Press ENTER.

This display will only be indicated if the calculation of the temperature offset is enabled in the menu item `Options\Special settings\Fluid: c -> T`.

#### Notice!

After starting the measurement the determination of the offset can last up to 2 minutes (100 sound speed measurements are averaged).

If an offset for the calculation of the temperature from a previous measurement is stored in the transmitter, when starting a measurement, it will be requested whether a calibration is to be carried out. The currently stored offset will be displayed (here: 2.7 K).

Measurement\Fluid: c -> T  $\Delta$ 2.7K

- Select `Keep calibration` if the currently stored offset is to be used.
- Press ENTER.
- Select `New calibration` if the offset has to be redefined.
- Press ENTER.

Measurement\Fluid temp.

- Enter the calculated fluid temperature.
- Press ENTER.

This display will only be indicated if `New calibration` is selected.

#### Input of the sound path number

Measurement\Sound path

- Enter the number of sound paths.
- Press ENTER.

#### Adjustment of the transducer distance

Measurement\Transducer distance

The recommended transducer distance will be displayed. The transducer distance is measured between the inner edges of the transducers. In case of a measurement in diagonal arrangement on very small pipes, a negative transducer distance is possible.

#### Notice!

The accuracy of the recommended transducer distance depends on the accuracy of the entered pipe and fluid parameters.

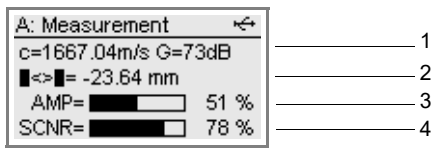
- Mount the transducers on the pipe and adjust the recommended transducer distance.
- Press ENTER.

The diagnostics window is displayed.

The amplitude of the received signal is displayed by bar graph `AMP`.

The bar graph `SCNR` shows the ratio of the useful signal and the correlated noise signal.

Fig. 9.1: Diagnostics window



- 1 – diagnostic value, selection with
- 2 – diagnostic value, selection with
- 3 – amplitude (bar graph)
- 4 – SCNR value (bar graph)

Tab. 9.4: Diagnostic values

	display <sup>(1)</sup>	explanation
line 1 of the display scroll with <input type="button" value="9"/>	c, G	measured sound speed of the fluid and signal amplification
	SCNR	signal-to-correlated noise ratio
	SNR	signal-to-noise ratio
	Q	signal quality By pressing <input type="button" value="8"/> it is possible to display the numeric value instead of the bar graph.
	GAIN	signal amplification If the current signal amplification value exceeds the max. amplification, it is followed by →FAIL!.
line 2 of the display scroll with <input type="button" value="3"/>	■<>■	recommended transducer distance
	SCNR	signal-to-correlated noise ratio
	SNR	signal-to-noise ratio
	Q	signal quality By pressing <input type="button" value="2"/> it is possible to display the numeric value instead of the bar graph.

<sup>(1)</sup> In order to avoid doubling, a value already displayed in one of the lines will be ignored in the other.

- In case of large diagnostic value deviations of the recommended limits, check if the entered parameters are correct or repeat the measurement at a different point on the pipe.
- Press ENTER.

Tab. 9.5: Recommended diagnostic limits

good measurement	measurement at limit	measurement not possible
SCNR > 30 dB (> 50 %)	20 dB ≤ SCNR ≤ 30 dB (0 % < SCNR ≤ 50 %)	SCNR < 20 dB (= 0 %)
SNR > 15 dB	0 dB ≤ SNR ≤ 15 dB	SNR < 0 dB
GAIN < 98 dB	98 dB ≤ GAIN ≤ 113 dB	GAIN > 113 dB

### Input of the transducer distance

```
Measurement\Transducer distance
```

The recommended transducer distance is calculated on the basis of the measured sound speed. It is therefore a better approximation than the first recommended value which had been calculated on the basis of the sound speed range entered in the program branch *Parameters*.

- Measure the adjusted transducer distance.
- Enter the measured transducer distance. The max. permissible difference to the recommended transducer distance must not be exceeded.
- Press ENTER.

The measurement is started. The measured values are displayed.

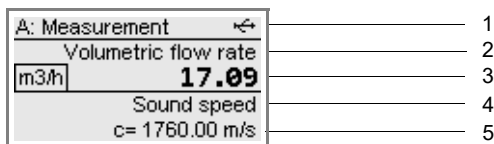
Tab. 9.6: Max. permissible deviation between the recommended and entered transducer distance

transducer frequency (3rd character of the technical type)	max. difference between the recommended and entered transducer distance [mm]	
	shear wave transducer	Lamb wave transducer
F	-	-60...+120
G	20	-45...+90
H	-	-30...+60
K	15	-20...+40
M	10	-10...+20
P	8	-5...+10
Q	6	-3...+5
S	3	-

## 9.4 Display of measured values

The measured values are displayed during the measurement as follows:

Fig. 9.2: Display of measured values



- 1 – channel, program branch, status indicators
- 2 – physical quantity
- 3 – unit of measurement and measured value
- 4 – further physical quantities
- 5 – further physical quantities

By pressing **[3]** or **[9]**, additional physical quantities can be displayed during the measurement.

- Press **[3]** to display the measured values in line 5. The designation of the physical quantity is displayed in line 4 by pressing **[9]** for several seconds.
- Press **[9]** to display the measured values in line 4. The designation of the physical quantity is displayed in line 5 by pressing **[3]** for several seconds.

### Toggling between the channels

If the measurement is started on several channels, the display of the measured values can be adapted as follows:

#### AutoMux mode

If the AutoMux mode is activated, the measured values of all activated channels (measuring and calculation channels) are displayed consecutively. The next active channel is selected after 3 s. The toggle time can be changed in the menu item *Special functions\Dialogs\Menus\Toggle time*.

#### HumanMux mode

The measured values of one channel are displayed in the HumanMux mode. The measurement on the other channels continues.

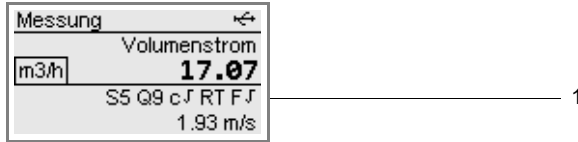
- Press **[7]** to display the next activated channel. The measured values for the selected channel are displayed.

Each measurement starts in AutoMux mode. Press **[1]** to toggle between the modes.

**Status line**

Important information of the running measurement is summarized in the status line. The quality and precision of the measurement can be evaluated. Press 9 during the measurement to scroll to the status line.

Fig. 9.3: Display of the status line



1 – status line

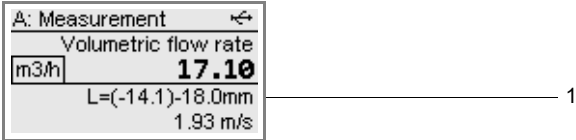
Tab. 9.7: Description of the status line

	value	explanation
S	0 ... 9	<b>signal amplitude</b>  < 5 % ... ≥ 90 %  values ≥ 3 are sufficient for the measurement
Q	0 ... 9	<b>signal quality</b>  < 5 % ... ≥ 90 %
c	√ ↑ ↓ ?	<b>sound speed</b> comparison of the measured and the expected sound speed of the fluid  The expected sound speed is calculated from the fluid parameters. The expected sound speed is calculated from the fluid parameters.  OK, is equal to the expected value > 20 % of the expected value < 20 % of the expected value unknown, cannot be measured
	T L ↑ ↓ ?	<b>flow profile</b> information about the flow profile based on the Reynolds number  fully turbulent flow profile fully laminar flow profile transition range between laminar and turbulent flow unknown, cannot be calculated
F	√ ↑ ↓ 0 ?	<b>flow velocity</b> comparison of the measured flow velocity with the flow limits of the system  OK, the flow velocity is not within the critical range the flow velocity is higher than the current limit the flow velocity is lower than the current cut-off flow the flow velocity is within the limit range of the measuring method unknown, cannot be measured

### Transducer distance

By pressing **9** during the measurement, it is possible to scroll to the display of the transducer distance.

Fig. 9.4: Display of the transducer distance



1 – transducer distance

The recommended transducer distance will be displayed in brackets, the measured transducer distance will be displayed afterwards. The recommended transducer distance might change during the measurement (e.g., due to temperature fluctuations). A deviation from the recommended transducer distance will be compensated internally.

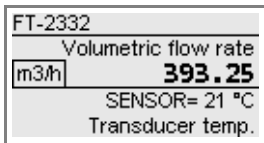
<b>Notice!</b>
Never change the transducer distance during the measurement.

### Transducer temperature

In the `SuperUser` and `SuperUser ext.` modes it is possible to display the transducer temperature during the measurement.

By pressing **9** during the measurement, it is possible to scroll to the transducer temperature display.

Fig. 9.5: Display of the transducer temperature



<b>Notice!</b>
If the compliance of the specified transducer temperature has to be monitored, an event trigger can be set on the temperature value.

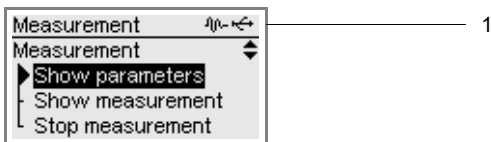
## 9.5 Display of parameters

The parameters can be displayed during the measurement.

- Press **5** during the measurement.

The following display appears:

Fig. 9.6: Scroll list in the program branch `Measurement`



1 – status indication

The measurement is running in the background. The symbol  is displayed in the status indication.

Measurement\Show parameters

- Select `Show parameters` in the scroll list.
- Press ENTER.



The program branch `Measurement` is displayed.

- Select another program branch to display the parameters.

### Notice!

The parameters cannot be changed during the measurement. When attempting to change the parameters, the message `Read-only mode` will be displayed.  
The measurement has to be stopped in order to change the parameters.

### Information regarding the data logger

Information regarding the data logger can be displayed during the measurement.

- Press `9` until the following is displayed:

Fig. 9.7: Information regarding the data logger

Measurement	↔
Volumetric flow rate	
m <sup>3</sup> /h	<b>3.69</b>
Log↔: 6d 21h 9m	
Capacity (time)	

If the ringbuffer is deactivated, line 4 indicates when the data logger will be full in case all settings are kept.

If the ringbuffer is activated, line 4 indicates how long measurement data can still be stored without losing older measurement data.

The information regarding the data logger can also be displayed using the function `Show parameters`.

```
Special functions\Data logger
```

- Select the list item `Data logger` in the menu item `Data logger info`.
- Press ENTER.

The information regarding the data logger will be displayed.

### Display of the current temperature offset

If the calculation of the fluid temperature from the sound speed is activated, the temperature offset can be displayed during the measurement.

```
Options\Special settings\Fluid: c -> T
```

- Select the menu item `Special settings` in the program branch `Options`.
- Press ENTER until the menu item `Fluid: c -> T` is displayed.

The following display appears:

Fig. 9.8: Display of the temperature offset

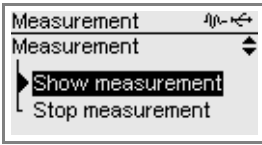
Options	↔
Fluid: c -> T	
Temperature offset	
2.68 K	

### 9.6 Repeated display of measured values

- Select the program branch `Measurement` to return to the measured value display.
- Press ENTER.

The following display appears:

Fig. 9.9: Scroll list in the program branch `Measurement`



`Measurement\Show measurement`

- Select `Show measurement` in the scroll list.
- Press ENTER.

The measured values are displayed.

### 9.7 Execution of special functions

Some of the keys have special functions. They can be used to enter data, to navigate through scroll lists and to execute special functions.

Tab. 9.8: Special functions

key	function
[1]	toggling between the AutoMux and HumanMux mode
[8]	totalizer display
[5]	triggering of snaps
[6]	press and hold to toggle between the alternating and standard measured values display (only for thermal energy rate measurement)
[7]	toggling between the displays of the activated channels
[0]	toggling between the TransitTime and the FastFood mode
[-]	toggling between the TransitTime and the NoiseTrek mode
[↩]	display of the scroll list in the program branch <code>Measurement</code>
ENTER	display of the diagnostic window

Some function are executed in the context of the channel that was last visible on the display.

- Press and hold C until the menu item `Execute command` is displayed.

#### Totalizers

`Measurement\Execute command\Totalizers`

- Select the list item `Totalizers`.
- Press ENTER.

The following scroll list appears:

display	description
Reset totalizers	reset the totalizer to zero
Freeze display	display the measured value of the totalizer for several seconds
Reset error	reset the totalizer error
Stop/clear totalizers	stop totalizer and reset it to zero
Start totalizers	start totalizer

### Measuring mode

If the NoiseTrek or FastFood mode is enabled, it is possible to toggle between the modes.

```
Measurement\Execute command\Measuring mode
```

- Select the list item `Measuring mode`.
- Press ENTER.
- Select a measuring mode.
- Press ENTER.

### Channel toggling

If the measurement is started on several channels, the display of the measured values can be adapted as follows:

```
Measurement\Execute command\Channel toggling
```

- Select the list item `Channel toggling`.
- Press ENTER.

During the measurement, the measured values of channel A or B can be displayed or it is toggled automatically between these channels.

- Select a list item for channel toggling.
- Press ENTER.

### Taking a snap

```
Measurement\Execute command\Take a snap
```

- Select the list item `Take a snap`.
- Press ENTER.

A snap will be taken.

This display will only be indicated if snap function is enabled in the menu item `Special functions\Snap\Configuration\Snap`.

### Reset the event trigger to idle state

```
Measurement\Execute command\Clear alarms
```

- Select the list item `Clear alarms`.
- Press ENTER.

This display will only be indicated if an event trigger has been parameterized and at least one event trigger has also been triggered.

### toggling option for alternating and standard measured value display (only for thermal energy rate measurement)


```
Measurement\Execute command\Display toggling on
```

- Select the list item `Display toggling on` to activate the toggling option alternating and standard measured value display (only for thermal energy rate measurement).
- Press ENTER.

```
Measurement\Execute command\Display toggling off
```

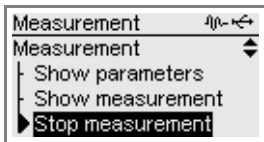
- Select the list item `Display toggling off` to deactivate this function.
- Press ENTER.

## 9.8 Stop of the measurement

- Press  during the measurement.

The following display appears:

Fig. 9.10: Scroll list in the program branch `Measurement`



```
Measurement\Stop measurement
```

- Select `Stop measurement`.
- Press ENTER.

The measurement is stopped. The program branch `Parameters` is displayed.

After disconnecting and reconnecting the power supply, the program branch `Parameters` appears.

## 10 Troubleshooting

### Danger!



#### Risk of explosion when using the measuring equipment in explosive atmospheres (ATEX, IECEx)

This may result in personal or material damage or dangerous situations.

→ Observe the "Safety instructions for the use in explosive atmospheres" (see document SIFLUXUS).

### Danger!



#### Risk of explosion when using the measuring equipment in explosive atmospheres (TR TS)

This may result in personal or material damage or dangerous situations.

→ Observe the "Safety instructions for the use in explosive atmospheres" (see document SIFLUXUSRU).

### Warning!



#### Service works by unauthorized and unqualified personnel

This may result in personal or material damage or dangerous situations.

→ Any work on the transmitter has to be carried out by authorized and qualified personnel.

### Danger!



#### Working in mines or cramped confines

Risk of intoxication and/or asphyxiation because of emerging gases, risk of injuries because of cramped conditions.

→ Wear the required personal protective equipment.

→ Observe the applicable rules.

### Caution!



#### Safety and accident prevention regulations for electrical systems and equipment

Failure to observe these regulations may lead to severe injuries.

→ Observe the safety and accident prevention regulations for electrical systems and equipment.

### Warning!



#### Touching live parts

Electric shock or arc faults can lead to severe injuries. The measuring equipment can be damaged.

→ Prior to any work on the transmitter (e.g., installation, dismounting, connection, start-up), the transmitter has to be disconnected from the power supply. It is not sufficient to remove the internal fuse of the instrument.

### Caution!



#### Touching hot or cold surfaces

This may result in injuries (e.g., thermal damages).

→ Observe the ambient conditions at the measuring point during installation.

→ Wear the required personal protective equipment.


→ Observe the applicable rules.

If any problem appears which cannot be solved with the help of this operating instruction, contact our sales office and give a precise description of the problem. Specify the type, the serial number and the firmware version of the transmitter.

**The display does not work at all or fails regularly.**

- Check the contrast setting of the transmitter or enter the HotCode **555000** to set the display to medium contrast.
- Make sure that the correct voltage is available at the terminals. The destined transmitter voltage is indicated on the nameplate below the outer right terminal strip.
- If the power supply is OK, the transducers or an internal component of the transmitter are defective. The transducers and the transmitter have to be sent to FLEXIM for repair.
- If the transmitter is only connected via the USB interface, the backlight will be switched off.

**An error is displayed in the status indication (symbol ).**

- Press  to return to the main menu.
- Select the menu item `Special functions\System settings\Event log`.
- Press ENTER.

The error message list will be displayed.

**Date and time are wrong, the measured values are deleted when the transmitter is switched off.**

- If the date and the time are reset or wrong or the measured values are deleted after the transmitter has been switched off and on again, the data backup battery has to be replaced. Send the transmitter to FLEXIM.

**An output does not work.**

- Make sure that the outputs are configured correctly. Check the function of the output. If the output is defective, contact FLEXIM.

## 10.1 Problems with the measurement

**A measurement is not possible because no signal is received. An interrogation point is displayed after the physical quantity. The LED lights red after starting the measurement.**

- Check whether the entered parameters are correct, especially the outer pipe diameter, the pipe wall thickness and the sound speed of the fluid. Typical errors: The circumference or the radius was entered instead of the diameter. The inner pipe diameter was entered instead of the outer pipe diameter.
- Check the number of sound paths.
- Make sure that the recommended transducer distance was adjusted when mounting the transducers.
- Make sure that an appropriate measuring point is selected and the number of sound paths was entered correctly.
- Try to establish a better acoustic contact between the pipe and the transducers.
- Enter a lower value for the number of sound paths. The signal attenuation might be too high due to a high fluid viscosity or deposits on the inner pipe wall.

**The measuring signal is received but no measured values can be obtained.**

- If the defined upper limit of the flow velocity is exceeded or the lower limit is below, UNDEF and after the physical quantity an exclamation point will be displayed. The measured values are marked as invalid. The limit has to be adapted to the measuring conditions.
- If no exclamation point is displayed, a measurement at the selected measuring point is impossible.

**The signal is lost during the measurement.**

- If there is no measuring signal after the pipe had been run empty and refilled, contact FLEXIM.
- Wait a moment until the acoustic contact is reestablished. The measurement can be interrupted due to a temporarily higher proportion of gas bubbles and solids in the fluid.

**The measured values substantially differ from the expected values.**

- Wrong measured values are often caused by wrong parameters. Make sure that the parameters entered for the measuring point are correct.

## 10.2 Measuring point selection

- Make sure that the recommended min. distance to any disturbance is observed.
- Avoid measuring points with deposit formation in the pipe.
- Avoid measuring points in the vicinity of deformations and defects on the pipe as well as welds.
- Make sure the pipe surface at the selected measuring point is even.
- Measure the temperature at the measuring point and make sure that the transducers are suitable for this temperature.
- Make sure that the outer pipe diameter is within the measuring range of the transducers.
- When measuring on a horizontal pipe, the transducers have to be mounted laterally on the pipe.
- A vertical pipe always has to be filled at the measuring point and the fluid should flow upward.
- No gas bubbles should form (even bubble-free fluids can form gas bubbles when the fluid expands, e.g., upstream of pumps and downstream of great cross-section enlargements).

## 10.3 Maximum acoustic contact

- see section 6.2

## 10.4 Application-specific problems

### **A fluid with a wrong sound speed was selected.**

- If the selected sound speed in the fluid does not match the actual one, the transducer distance may not be determined correctly.
- The fluid sound speed is used to calculate the transducer distance and is therefore very important for the transducer positioning. The sound speeds stored in the transmitter only serve as an orientation.

### **The entered pipe roughness is not appropriate.**

- Check the entered value considering the pipe condition.

### **Measurements on pipes made of porous materials (e.g., concrete or cast iron) are only conditionally possible.**

- Contact FLEXIM.

### **The pipe lining may cause problems during the measurement if it is not firmly attached to the inner pipe wall or consists of an acoustically absorbing material.**

- Try to measure on a section of the pipe free from lining.

### **Highly viscous fluids strongly attenuate the ultrasonic signal**

- The measurement of fluids with a viscosity of  $> 1000 \text{ mm}^2/\text{s}$  is only conditionally possible.

### **Gas bubbles or solids present in high concentration in the fluid scatter and absorb the ultrasonic signal and thus attenuate the measuring signal**

- A measurement is impossible if the value is  $\geq 10 \%$ . If the proportion is high, but  $< 10 \%$ , a measurement is only conditionally possible.

## 10.5 Significant deviations of the measured values

### A fluid with a wrong sound speed was selected.

- If a fluid was selected whose sound speed does not match the actual one, a pipe wall signal can be mistaken for the measuring signal. The flow calculated by the transmitter on the basis of the wrong signal is very small or fluctuates around zero.

### There is gas in the pipe.

- If there is gas in the pipe, the measured flow will be too high because both the liquid and the gas volume are measured.

### The defined upper limit of the flow velocity is too low.

- All measured flow velocities that are greater than the upper limit will be ignored and marked as invalid. All quantities deviated from the flow velocity will also be indicated as invalid. If several correct measured values are ignored, the totalizer values will be too low.

### The entered cut-off flow is too high.

- All flow velocities below the cut-off flow are set to zero. All derived quantities are also set to zero. The cut-off flow has to be set to a low value to be able to measure at low flow velocities (default: 2.5 cm/s).

### The entered pipe roughness is not appropriate.

### The flow velocity of the fluid is outside the measuring range of the transmitter.

### The measuring point is not appropriate.

- Check whether a different measuring point provides better results. Because pipes are never rotationally symmetric and the flow profile is affected.

## 10.6 Problems with the totalizers

### The values of the totalizers are too small.

- One of the totalizers has reached the upper limit and has to be reset to zero manually.

### The sum of the totalizers is not correct.

- The sum of both totalizers (throughput  $\Sigma Q$ ) transmitted via an output is not valid after one of the totalizers has overflowed for the first time.

### An interrogation point is displayed after the value of the totalizer.

- The measurement was temporarily impossible, therefore the totalizer value can be wrong.

## 10.7 Problems during the thermal energy rate measurement

### The measured fluid temperatures differ from the actual values.

- The temperature probes are not sufficiently insulated.
- On a pipe with a small diameter, the temperature probe is lifted from the pipe surface by the insulation foam.

### The measured absolute value of the thermal energy rate is correct but has the opposite sign.

- Check the assignment of the supply and return temperature to the temperature inputs.

### The calculated thermal energy rate differs from the actual one although the measured flow and temperature values are correct

- Check the thermal energy rate coefficient of the fluid.



## 11 Maintenance and cleaning

### Danger!



#### **Risk of explosion when using the measuring equipment in explosive atmospheres (ATEX, IECEx)**

This may result in personal or material damage or dangerous situations.

→ Observe the "Safety instructions for the use in explosive atmospheres" (see document SIFLUXUS).

### Danger!



#### **Risk of explosion when using the measuring equipment in explosive atmospheres (TR TS)**

This may result in personal or material damage or dangerous situations.

→ Observe the "Safety instructions for the use in explosive atmospheres" (see document SIFLUXUSRU).

### Warning!



#### **Service works by unauthorized and unqualified personnel**

This may result in personal or material damage or dangerous situations.

→ Any work on the transmitter has to be carried out by authorized and qualified personnel.

### Danger!



#### **Working in mines or cramped confines**

Risk of intoxication and/or asphyxiation because of emerging gases, risk of injuries because of cramped conditions.

→ Wear the required personal protective equipment.

→ Observe the applicable rules.

### Warning!



#### **Touching live parts**

Electric shock or arc faults can lead to severe injuries. The measuring equipment can be damaged.

→ Prior to any work on the transmitter (e.g., installation, dismantling, connection, start-up), the transmitter has to be disconnected from the power supply. It is not sufficient to remove the internal fuse of the instrument.

### Caution!



#### **Safety and accident prevention regulations for electrical systems and equipment**

Failure to observe these regulations may lead to severe injuries.

→ Observe the safety and accident prevention regulations for electrical systems and equipment.

### Caution!



#### **Touching hot or cold surfaces**

This may result in injuries (e.g., thermal damages).

→ Observe the ambient conditions at the measuring point during installation.

→ Wear the required personal protective equipment.

→ Observe the applicable rules.

## 11.1 Maintenance

The transmitter and the transducers are practically maintenance-free. In order to ensure security, the following maintenance intervals are recommended:

Tab. 11.1: Recommended maintenance intervals

item	maintenance step	interval	measure
stainless steel housing • transmitter • junction box • transducer mounting fixture	visual inspection for corrosion and damages	annually or more frequently, depending on the ambient conditions	cleaning
	visual inspection for contamination	annually or more frequently, depending on the ambient conditions	
aluminum housing • transmitter	visual inspection for contamination	annually or more frequently, depending on the ambient conditions	
transducers	check of the transducer coupling on the pipe	annually	replacement of coupling foil, if necessary
transmitter	check for firmware updates	annually	update, if necessary
transmitter	functional test	annually	reading of measured and diagnostic values
transmitter and transducers	calibration	-	see section 11.3

## 11.2 Cleaning

### Stainless steel housing

- Clean the housing with a soft cloth and care and cleaning spray for stainless steel.

### Aluminum housing

- Clean the housing with a soft cloth. Do not use detergents.

### Transducers

- Remove traces of coupling compound from the transducers with a soft paper towel.

## 11.3 Calibration

If installed as recommended in an appropriate location, used cautiously and serviced conscientiously, no troubles should appear.

The transmitter has been calibrated at factory and, usually, a recalibration is not necessary.

A recalibration is recommended if:

- the contact surfaces of the transducers show visible wear
- the transducers were used for a prolonged period at high temperatures (several months > 130 °C for normal transducers or > 200 °C for high temperature transducers)

In order to realize a recalibration under reference conditions, either the transmitter, the transducers or both have to be sent to FLEXIM.

## 11.4 Firmware update

A firmware update is carried out with FluxDiagReader or FluxDiag (option).

- For the connection of the transmitter to a PC, see section 7.6.
- For the operation of FluxDiagReader or FluxDiag see the help functions of these programs.

## 12 Dismounting and disposal

### Danger!



#### **Risk of explosion when using the measuring equipment in explosive atmospheres (ATEX, IECEx)**

This may result in personal or material damage or dangerous situations.

→ Observe the "Safety instructions for the use in explosive atmospheres" (see document SIFLUXUS).

### Danger!



#### **Risk of explosion when using the measuring equipment in explosive atmospheres (TR TS)**

This may result in personal or material damage or dangerous situations.

→ Observe the "Safety instructions for the use in explosive atmospheres" (see document SIFLUXUSRU).

### Warning!



#### **Installation, connection and start-up by unauthorized and unqualified personnel**

This may result in personal or material damage or dangerous situations.

→ Any work on the transmitter has to be carried out by authorized and qualified personnel.

### Danger!



#### **Working in mines or cramped confines**

Risk of intoxication and/or asphyxiation because of emerging gases, risk of injuries because of cramped conditions.

→ Wear the required personal protective equipment.

→ Observe the applicable rules.

### Warning!



#### **Touching live parts**

Electric shock or arc faults can lead to severe injuries. The measuring equipment can be damaged.

→ Prior to any work on the transmitter (e.g., installation, dismounting, connection, start-up), the transmitter has to be disconnected from the power supply. It is not sufficient to remove the internal fuse of the instrument.

### Caution!



#### **Safety and accident prevention regulations for electrical systems and equipment**

Failure to observe these regulations may lead to severe injuries.

→ Observe the safety and accident prevention regulations for electrical systems and equipment.

## 12.1 Dismounting

Dismounting is carried out in reverse order to the installation.

## 12.2 Disposal

The measuring equipment has to be disposed of in accordance with the applicable regulations.

### Important!

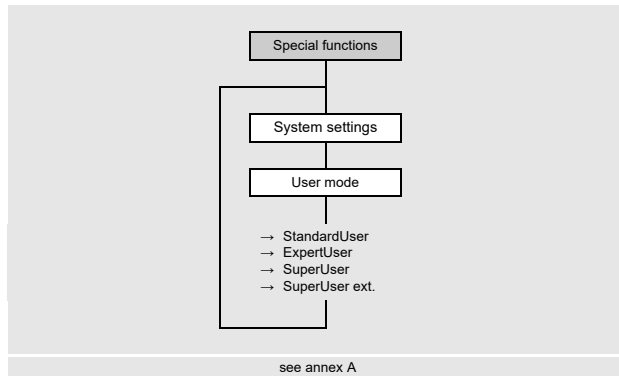
**Proper disposal of components of the transmitter and accessories that are no longer required avoids environmental damage and conserves resources.**

Depending on the material, the corresponding parts have to be disposed of in residual or special waste or recycled in accordance with the applicable regulations.

Batteries must be disposed of separately from electrical or electronic equipment. For this purpose, remove the batteries from the device and take them to the designated disposal system.

The components are taken back free of charge by FLEXIM in accordance with national regulations. Contact FLEXIM.

## 13 User modes



The user modes allow extended diagnostics of signals and measured values as well as the definition of additional parameters adapted to the application.

The following user modes can be selected:

- StandardUser
- ExpertUser
- SuperUser
- SuperUser ext.

Depending on the selected user mode, further options are displayed in the program branch `Options\Channel\Special settings`.

Tab. 13.1: Menu items of the user modes

Options\Special settings	StandardUser	ExpertUser	SuperUser	SuperUser ext.	default
Cut-off flow	x	x	x	x	On
Flow velocity limit		x	x	x	Off
Enable NoiseTrek	x	x	x	x	Off
Pig detection			x	x	Off
Turbulence mode	x	x	x	x	Off
Max. amplification		x	x	x	Off
Pipe signal detection		x	x	x	On
LWT pipe wall calibr.			x	x	Off
Linear calibration			x	x	Off
Profile correction		x	x	x	On
Weighting factor			x	x	Off
Fluid: c -> T	x	x	x	x	Off
Multi-point calibration (if enabled in Special functions\Measurement\ Measurement settings)	x	x	x	x	
Start in meas. mode	x	x	x	x	
Transducer temp. and Transd. temp. violat. (as source item Diagnostic values)			x	x	
Extended diagnostics (in the program branch Options, calculation channel)		x	x	x	

## User mode selection

Special functions\System settings\User mode

- Select the menu item `User mode`.
- Press ENTER.
- Select a list item.
- Press ENTER.

## Special settings

Options\Channel\Special settings

- Select the measuring channel in the program branch `Options`.
- Press ENTER.
- Select the list item `Special settings`.
- Press ENTER.

The menu items of the user mode are consecutively displayed.

FLUXUS \*722:

If the synchronized channel averaging is activated in the menu item `Special functions\Measurement\Measurement modes\Synch. chan. averag.`, the measuring channels A and B are not separately parameterized (display: `Channel AB`).

## 13.1 StandardUser mode

In the StandardUser mode, all measurements can be carried out for the corresponding application. At the first start-up the transmitter operates in the StandardUser mode.

### 13.1.1 Cut-off flow

The cut-off flow is a lower limit for the flow velocity. All measured flow velocities that are below the limit are set to zero. The cut-off flow can depend on the flow direction.

Options\Special settings\Cut-off flow

- Select the menu item `Options\Special settings`.
- Press ENTER until the menu item `Cut-off flow` is displayed.
- Select `Off` if no value is to be entered for the cut-off flow.
- Select `Default` if no customized inputs are to be made (default:  $\pm 25$  mm/s).
- Select `Customized` to define the values of the cut-off flow for the positive and negative flow direction.
- Press ENTER.

Options\Special settings\+Cut-off flow

All values of the flow velocity for the positive flow direction below this limit are set to zero.

- Enter the cut-off flow.
- Press ENTER.

Options\Special settings\ -Cut-off flow

All values of the flow velocity for the negative flow direction (as absolute value) below this absolute limit are set to zero.

- Enter the cut-off flow as absolute value.
- Press ENTER.

### 13.1.2 NoiseTrek mode

If the proportion of gas or solid particles is high, the transmitter can toggle to the NoiseTrek mode.

#### Notice!

Due to its higher measuring accuracy, the TransitTime mode should be preferred to the NoiseTrek mode.

In the NoiseTrek mode it is not possible to determine the sound speed in the fluid.

The following diagnostic values are not available in the NoiseTrek mode: signal quality, amplitude fluctuation, transit time fluctuation, pig detection.

```
Options\Special settings\Enable NoiseTrek
```

- Select the menu item `Special settings` in the program branch `Options`.
- Press ENTER until the menu item `Enable NoiseTrek` is displayed.
- Select `Default` if no customized inputs are to be made.
- Select `On` to enable the NoiseTrek mode and `Off` to disable it.
- Press ENTER.

If `On` has been selected, the following list items are available:

- `Manual`
- `HybridTrek`
- `Parallel beam`

FLUXUS \*722:

If the synchronized channel averaging is activated in the menu item `Special functions\Measurement\Measurement modes\Synch. chan. averag.`, this function will not be available.

#### 13.1.2.1 Manual

In order to manually toggle between the TransitTime and the NoiseTrek mode during the measurement, press  when the measured value is displayed.

#### 13.1.2.2 HybridTrek mode

The HybridTrek mode combines the TransitTime and the NoiseTrek mode. During a measurement in the HybridTrek mode, the transmitter automatically toggles between the TransitTime and the NoiseTrek mode depending on the proportion of gas bubbles and solid particles in the fluid in order to receive valid measuring values.

If the NoiseTrek mode is enabled, the menu item `HybridTrek` will be displayed.

```
Options\Special settings\HybridTrek
```

- Select `On` to activate the automatic toggling between the TransitTime and the NoiseTrek mode. If `On` is selected, the NoiseTrek mode can also be activated and deactivated manually during the measurement.
- Select `Off` to deactivate the automatic toggling between the TransitTime and the NoiseTrek mode. If `Off` is selected, the NoiseTrek mode can only be manually activated and deactivated during the measurement.
- Press ENTER.

```
Options\Special settings\HybridTrek\TT -> NT
```

If the automatic toggling between the TransitTime and NoiseTrek mode is activated, further parameters have to be configured.

- Enter the time after which the transmitter has to toggle to the NoiseTrek mode if there are no valid measured values in the TransitTime mode.
- Press ENTER.

```
Options\Special settings\HybridTrek\NT -> TT
```

- Enter the time after which the transmitter has to toggle from the NoiseTrek to the TransitTime mode if there are no valid measured values.
- Press ENTER.

```
Options\Special settings\HybridTrek\NT -> TT possible
```

If there are valid measured values in the NoiseTrek mode, the transmitter can periodically toggle to the TransitTime mode in order to check whether a measurement in the TransitTime mode is possible again. The time interval and the checking duration are set as follows:

- Enter the time after which the transmitter has to toggle to the TransitTime mode. If zero is entered, the transmitter does not toggle to the TransitTime mode.
- Press ENTER.

```
Options\Special settings\HybridTrek\Keep TT
```

- Enter the time after which the transmitter has to toggle from the TransitTime mode back to the NoiseTrek mode if there are no valid measured values.
- Press ENTER.

### Example

```
TT -> NT: 40s  
NT -> TT: 60s  
NT -> TT possible: 300s  
Keep TT: 5s
```

If no measurement is possible in the TransitTime mode within 40 s, the transmitter toggles to the NoiseTrek mode. If no measurement is possible in the NoiseTrek mode within 60 s, the transmitter toggles back to the TransitTime mode.

If valid measured values are obtained during the measurement in the NoiseTrek mode, the transmitter toggles to the TransitTime mode every 300 s. If no measurement is possible in the TransitTime mode within 5 s, the transmitter toggles back to the NoiseTrek mode. If a valid measured value is obtained in the TransitTime mode within 5 s, the transmitter continues the measurement in the TransitTime mode.

#### 13.1.2.3 NoiseTrek parallel beam mode

The NoiseTrek parallel beam mode works with parallel mounted transducers. It improves the signal quality when measuring on small pipes or with strongly attenuating fluids.

#### 13.1.3 Turbulence mode

In the presence of high turbulence, i.e., high Reynolds numbers or disturbed flow profiles due to short inlet and outlet lengths, there are large fluctuations in the transit time of the ultrasonic signals, resulting in poor signal quality (e.g., reduction in signal amplitude, increase in gain). An unstable measurement with frequent signal losses and diagnostic values VariAmp > 5 % indicate strong turbulence. Here it can be helpful to activate the turbulence mode.

##### Requirement for a measurement with activated turbulence mode

- The SNR has to be > 15 dB with deactivated turbulence mode.
- The signal amplification with activated turbulence mode is min. 3 dB smaller than with deactivated turbulence mode. For this purpose, the signal amplification must be measured in each case at flow velocities at the operating point where strong turbulence is suspected.

If these criteria are fulfilled, the specified measurement uncertainty can also be met with activated turbulence mode.

If they are not fulfilled, the measurement with deactivated turbulence mode is to be preferred.



`Options\Special settings\Turbulence mode`

- Select the menu item `Special settings` in the program branch `Options`.
- Press ENTER until the menu item `Turbulence mode` is displayed.
- Select `On` to activate the turbulence mode. Select `Off` to deactivate it. Select `Default` if no customized inputs are to be made.
- Press ENTER.

#### 13.1.4 Multi-point calibration

It is possible to enter a series of measured values in order to define a calibration curve for the flow velocity.

Record of a series of measured values:

- Start a measurement with the transmitter and a reference flowmeter.
- Gradually increase the value of the flow velocity. The measuring range of values has to be identical with the eventual operating range.
- Note or store the measured values.

Input of a series of measured values:

- Select the menu item `Special settings` in the program branch `Options`.
- Press ENTER until the menu item `Multi-point calibration` is displayed.

`Options\Special settings\Multi-point calibration`

- Select `Yes` to define the calibration curve. Select `No` to measure without calibration.
- Press ENTER.

`Options\Special settings\Multi-point calibration\Calibration points`

- Enter the number of pairs of measured values.
- Press ENTER.

`Options\Special settings\Multi-point calibration\Point x=act. value`

- Enter the measured value of the transmitter.
- Press ENTER.

`Options\Special settings\Multi-point calibration\Point x=set value`

- Enter the measured value of the reference flowmeter.
- Press ENTER.
- Repeat the input for all pairs of measured values.
- Press ENTER after each input.

`Options\Special settings\Multi-point calibration\Bidirectional use`

- Select `Yes` to apply the calibration curve for negative flow velocities as well. Select `No` if it is not to be used for negative flow velocities.

### 13.1.5 Start in measuring mode

For some application it is necessary to start the measurement in a particular measuring mode.

Options\Special settings\Start in meas. mode

- Select the menu item `Special settings` in the program branch `Options`.
  - Press ENTER until the menu item `Start in meas. mode` is displayed.
- The menu item `Start in meas. mode` will only be displayed if `FastFood` or `NoiseTrek` mode is enabled.
- Select `TransitTime`, `FastFood`, `NoiseTrek` to start the measurement in the corresponding mode.
  - Press ENTER.

Options\Special settings\Start in meas. mode\Only ... mode

- Select `Yes` to keep always the same the measuring mode. Select `No` to select another measuring mode by pressing  during the measurement.

The measuring modes `FastFood` and `NoiseTrek` can only be selected if they are available and activated in the transmitter.

FLUXUS \*722:

If the synchronized channel averaging is activated in the menu item `Special functions\Measurement\Measurement modes\Synch. chan. averag.`, this function will not be available.

### 13.1.6 Calculation of the fluid temperature from the sound speed of the fluid

Options\Special settings\Fluid: c -> T

- Select the menu item `Special settings` in the program branch `Options`.
- Press ENTER until the menu item `Fluid: c -> T` is displayed.
- Select `On` if the calculated fluid temperature from the sound speed has to be calculated. Select `Off` if not.
- Press ENTER.

## 13.2 ExpertUser mode

Some menu items that are not visible in the `StandardUser` mode are displayed.

#### Notice!

The `ExpertUser` mode is intended for experienced users with advanced application knowledge. Changed parameters can affect the `StandardUser` mode and lead to wrong measured values or to a measurement failure when setting up a new measuring point.

#### Notice!

Some of the defined parameters remain activated when switching to the `StandardUser` mode. These parameters are displayed but cannot be changed.

### 13.2.1 Limit of the flow velocity

Single outliers caused by heavily disturbed surroundings can appear among the measured values of the flow velocity. If these outliers are not ignored, they will affect all derived physical quantities, which will be unsuitable for the integration (e.g., pulse outputs).

In the ExpertUser mode it is possible to enter a limit for the flow velocity.

It is possible to ignore all measured flow velocities higher or lower than the preset limit. In this case an error will be output.

Options\Special settings\Flow velocity limit

- Select the menu item `Special settings` in the program branch `Options`.
- Press `ENTER` until the menu item `Flow velocity limit` is displayed.
- Select `Off` if no limit for the flow velocity is to be used.
- Select `Default` if no customized inputs are to be made.
- Select `Customized` to define a limit for the flow velocity.
- Press `ENTER`.

Options\Special settings\+Flow velocity limit

- Enter a limit of the flow velocity for the measurement in flow direction.
- Press `ENTER`.

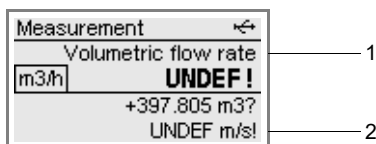
If the flow velocity is higher than this limit, it will be marked as invalid. The physical quantity cannot be determined. `UNDEF` will be displayed.

Options\Special settings\ -Flow velocity limit

- Enter a limit of the flow velocity for the measurement against the flow direction.
- Press `ENTER`.

If the flow velocity is lower than this limit, it will be marked as invalid. The physical quantity cannot be determined. `UNDEF` will be displayed.

Fig. 13.1: Flow velocity outside the valid range



- 1 – physical quantity
- 2 – flow velocity

#### Notice!

If the limit of the flow velocity `+Flow velocity limit` is too low or `-Flow velocity limit` is too high, a measurement might be impossible because most of the measured values will be marked as invalid.

### 13.2.2 Max. signal amplification

In order to prevent disturbing and/or pipe wall signals (e.g., if the pipe has run empty) from being interpreted as useful signals, it is possible to define a max. signal amplification.

If the signal amplification is greater than the max. signal amplification:

- the physical quantity cannot be determined and the measured value is marked as invalid
- a hash symbol will be displayed after the unit of measurement (in case of a normal error, an interrogation point is displayed)

Options\Special settings\Max. amplification

- Select the menu item `Special settings` in the program branch `Options`.
- Press ENTER until the menu item `Max. amplification` is displayed.
- Select `Off` if no limit of the signal amplification is to be used.
- Select `Default` if no customized inputs are to be made.
- Select `Customized` to define a limit for the max. amplification.
- Press ENTER.
- Enter a value for the max. signal amplification.
- Press ENTER.

### 13.2.3 Pipe signal detection

When evaluating the plausibility of the signal, it is checked whether the sound speed is within a defined range. The absolute threshold of the fluid sound speed used is calculated from the greatest of the following values:

- absolute threshold, default value: 1848 m/s
- value of the sound speed curve of the fluid at the operating point plus relative threshold, default relative threshold: 200 m/s

Options\Special settings\Pipe signal detection

- Select the menu item `Special settings` in the program branch `Options`.
- Press ENTER until the menu item `Pipe signal detection` is displayed.
- Select `Off` to measure without pipe signal detection.
- Select `Default` if no customized inputs are to be made and the default values are to be used.
- Select `Customized` to define the values of the pipe signal detection.
- Press ENTER.

Options\Special settings\Absolute threshold

- Enter the value of the absolute threshold for the particular measuring channel.
- Press ENTER.

Options\Special settings\Relative threshold

- Enter the value for the relative threshold for the particular measuring channel.
- Press ENTER.

### Example

absolute threshold: 2007 m/s

relative threshold: 600 m/s

value of the sound speed curve at the measuring point: 1546 m/s

As  $1546 \text{ m/s} + 600 \text{ m/s} = 2146 \text{ m/s}$  is greater than the absolute value 2007 m/s, this value will be used as the absolute limit of the sound speed when the plausibility of the signal is evaluated.

### 13.2.4 Profile correction

It is possible to select the following versions for the calculation of the fluid mechanic calibration factor  $k_{Re}$ :

- `kRe 1.0`: profile correction (previous version)
- `kRe 2.0`: improved profile correction (current version, default)
- `kRe 2.0 disturb. corr.`: improved profile correction at non ideal inflow conditions for the positive flow direction (negative flow direction without disturbance correction)
- `kRe 2.0 dist.corr.bidir.`: improved profile correction at non ideal inflow conditions for the positive and negative flow direction (automatic toggling of the profile correction depending on the flow direction)

The following steps are necessary to set the profile correction:

- selection of the profile correction version for all measuring channels in the program branch `Special functions`.
- selection of the disturbance type in the program branch `Parameters`
- input of the disturbance distance in the program branch `Parameters` if `kRe 2.0 disturb. corr.` or `kRe 2.0 dist.corr.bidir.` has been selected

#### Notice!

If `kRe 2.0 disturb. corr.` or `kRe 2.0 dist.corr.bidir.` has been selected, the transducers have to be mounted in reflection arrangement, X arrangement or displaced X arrangement to compensate cross-flow effects.

#### Selection of the version

```
Special functions\Measurement\Measurement settings\Profile correction
```

- Select the menu item `Measurement settings` in the program branch `Special functions`.
- Press ENTER until the menu item `Profile correction` is displayed.
- Select a list item (default: `kRe 2.0`).
- Press ENTER.

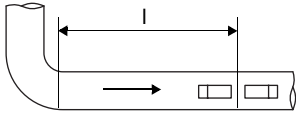
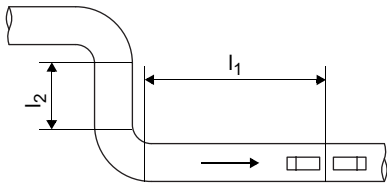
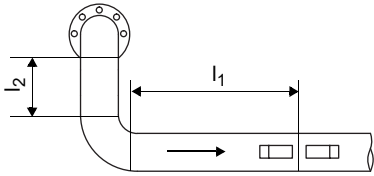
#### Selection of the disturbance

```
Parameters\Disturbance type
```

- Select a list item.
- Press ENTER.

If `kRe 2.0 disturb. corr.` or `kRe 2.0 dist.corr.bidir.` is selected, the disturbance parameters have to be entered.

Tab. 13.2: Disturbance parameters

disturbance type	further inputs	description
90° elbow	Disturbance distance ( $l_1$ )	
Double elbow	Disturbance distance ( $l_1$ ) Dist. between elbows ( $l_2$ )	
Double elb. out of plane	Disturbance distance ( $l_1$ ) Dist. between elbows ( $l_2$ )	

### 13.2.4.1 Measuring point specific profile correction

In special cases a measuring point specific profile correction can be used.

Options\Special settings\Profile correction

- Select the program branch `Options`.
- Press ENTER.
- Select a channel for which the profile correction is to be set.
- Select the menu item `Special settings`.
- Press ENTER until the menu item `Profile correction` is displayed.
- Select `Off` to deactivate the profile correction for the channel.
- Select `Default` to use the global setting from the program branch `Special functions` for the profile correction.
- Select `Customized` to use a measuring point specific profile correction.
- Press ENTER.

In case the list item `Customized` has been selected, the parameters of the measuring point specific profile correction will now be displayed. The parameters of the profile correction are preferably transmitted to the transmitter via the service interface but can also be entered here.

### 13.2.5 Advanced diagnosis

There are further diagnostic values available for the calculation channels. These can either be transmitted via the outputs of the transmitter or defined as source of the event trigger.

### 13.3 SuperUser mode and SuperUser ext. mode

Some menu items that are not visible in the StandardUser or ExpertUser mode are now displayed.

In the SuperUser ext. mode it is not possible to carry out any plausibility test of the entered parameters.

#### Notice!

The SuperUser and SuperUser ext. mode is intended for experienced users with advanced application knowledge. Changed parameters can affect the StandardUser mode and lead to wrong measured values or to a failure of the measurement when setting up a new measuring point.

#### Notice!

Some of the defined parameters remain activated when switching to the StandardUser mode. These parameters are displayed but cannot be changed.

#### 13.3.1 Pig detection

This function detects pigs inside the pipe. The pig detection can be activated/deactivated via the HotCode **007028** (default: deactivated).

Deviating from the global device settings, the pig detection for particular channels can be activated or deactivated.

```
Options\Special settings\Pig detection
```

- Select the menu item `Special settings` in the program branch `Options`.
- Press ENTER until the menu item `Pig detection` is displayed.
- Select `Global settings` if the measurement is to be carried out using the global settings of the transmitter.
- If the pig detection has been deactivated in the global device settings and the measurement is to be carried out with pig detection on this channel, select `On` for this channel.
- Press ENTER.
- If the pig detection has been activated in the global device settings and the measurement is to be carried out without pig detection on this channel, select `Off` for this channel.
- Press ENTER.

#### 13.3.2 Pipe wall calibration for Lamb wave transducers

The parameter record of a measuring channel for Lamb wave transducers has a calibration factor for the uncorrected flow velocity. This calibration factor depends on the pipe material.

The pipe wall calibration for Lamb wave transducers becomes effective if the following criteria are met when starting a measurement:

- Lamb wave transducers are used
- pipe wall calibration is activated
- a factor for the pipe material is defined and selected from the program branch `Parameters`

The factor can be activated in the transmitter.

```
Options\Special settings\LWT pipe wall calibr.
```

- Select the menu item `Special settings` in the program branch `Options`.
- Press ENTER until the menu item `LWT pipe wall calibr.` is displayed.
- Select `Off` to measure without pipe wall calibration.
- Select `Default` if no customized inputs are to be made.
- Select `On` to define the values for the pipe wall calibration.
- Press ENTER.

### 13.3.3 Linear calibration

It is possible to define a correction of the flow velocity:

$$v_{\text{cor}} = m \cdot v + n$$

where

- v – measured flow velocity
- m – factor, range: -2...+2
- n – offset, range: -12...+12 cm/s
- $v_{\text{cor}}$  – corrected flow velocity

All quantities derived from the flow velocity will be calculated with the corrected flow velocity.

#### Notice!

It will not be displayed during the measurement that the correction of the flow velocity is activated.

Options\Special settings\Linear calibration

- Select the menu item `Special settings` in the program branch `Options`.
- Press ENTER until the menu item `Linear calibration` is displayed.
- Select `Off` to measure without linear calibration.
- Select `Default` if no customized inputs are to be made.
- Select `On` to define the values for the calibration.
- Press ENTER.

Options\...\Factor

- Enter the factor for the linear calibration.
- Press ENTER.

Options\...\Offset

- Enter the offset for the linear calibration.
- Press ENTER.

#### Example

factor: 1.1

offset: -10 cm/s = -0.1 m/s

If a flow velocity  $v = 5$  m/s is measured, before the calculation of the derived quantities it will be corrected as follows:

$$v_{\text{cor}} = 1.1 \cdot 5 \text{ m/s} - 0.1 \text{ m/s} = 5.4 \text{ m/s}$$

#### Example

factor: -1

offset: 0

Only the sign of the measured values changes.

#### Notice!

The correction data will not be stored until a measurement is started.

If the transmitter is switched off without starting a measurement, the entered correction data will be lost.



### 13.3.4 Weighting factor

The weighting factor is used for transducers installed on the same pipe in order to compensate differences between the measured values of the flow velocity of different channels.

The differences can be caused by profile deformations or cross-flows. These influences can be reduced by averaging the measured values of several channels. If a channel has a temporary malfunction, the average will change abruptly. In order to avoid differences, all channels have to be adjusted with the weighting factor.

The weighting factor for the channel  $x$  results from the flow velocity  $v_x$  and the average flow velocity of all channels  $v_a$ :

$$w_x = \frac{v_m}{v_x}$$

The weighting factor can be activated in the transmitter.

Options\Special settings\Weighting factor

- Select the menu item `Special settings` in the program branch `Options`.
- Press ENTER until the menu item `Weighting factor` is displayed.
- Select `Off` to measure without the weighting factor.
- Select `Default` if no customized inputs are to be made.
- Select `On` to define the weighting factor.
- Press ENTER.

FLUXUS \*722:

If the synchronized channel averaging is activated in the menu item `Special functions\Measurement\Measurement modes\Synch. chan. averag.`, the weighting factor for the measuring channels A and B is separately entered.

### 13.3.5 Calculation of the fluid temperature from the sound speed of the fluid

Options\Special settings\Fluid: c -> T

- Select the menu item `Special settings` in the program branch `Options`.
- Press ENTER until the menu item `Fluid: c -> T` is displayed.
- Select `On` if the calculated fluid temperature from the sound speed has to be calculated. Select `Off` if not.
- Press ENTER.

If the transmitter is operating in the `SuperUser 0 SuperUser ext.` and `On` is selected, the options of temperature determination will be displayed.

Options\Special settings\Fluid: c -> T\Temperature meas.

- Select `With calibration` to realize a calibration for the temperature determination.
- From the difference between the entered fluid temperature and the sound speed of the calculated fluid temperature an offset is determined, when starting the measurement. The fluid temperature has to be entered.
- Press ENTER.
  - Select `Without calibration` if no measured value for the temperature is available.
  - Press ENTER.

#### Notice!

If the determination of the fluid temperature from the sound speed without calibration may lead to notable temperature deviations.

- Select `Customized` to enter an offset.
- Press ENTER.
- Enter the offset.
- Press ENTER.

### 13.3.6 Transducer temperature and transducer temperature violation as diagnostic value

When configuring outputs, the list items `Transducer temp.` and `Transd. temp. violat.` are available in the menu item `Diagnostic values`. The diagnostic values can either be transmitted via the output of the transmitter or defined as source of the event trigger. The diagnostic value `Transducer temp.` is available on measuring channels only.

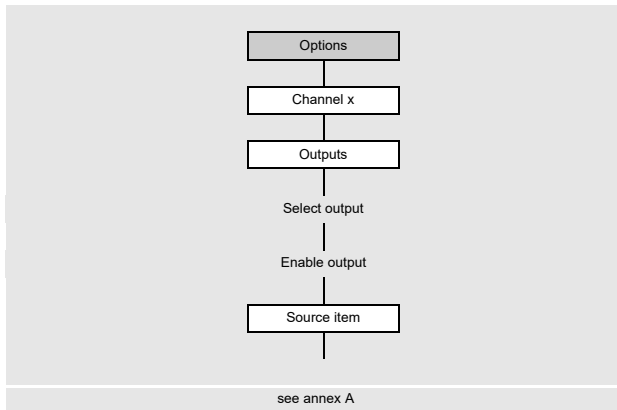
Options\Channel...\Outputs\...\Source item

- Select `Diagnostic values` as source item.
- Press ENTER.
- Select a list item for the quantity to be output.
- Press ENTER.

Tab. 13.3: Source item `Diagnostic values`

source item	list item	output
Diagnostic values	Transducer temp.	average temperature of both transducers
	Transd. temp. violat.	status information: yes/no

## 14 Outputs (TF7-\*721\*\*\_\*\*\*\*\*\_\*\*\*\*\*a-\*\*\*\*\*-\*\*; a = U, V, D)



If the transmitter is equipped with outputs, they have to be configured. For the configuration of the analog output, see section 9.2.6.

The transmitter can also be equipped with binary outputs. A binary output switches if one of the following switching conditions is met:

- the measured value exceeds or falls below a limit
- the measured value lays within or outside a defined range
- a measurement is not possible
- an event occurs

### 14.1 Configuration of a binary output

#### Assignment of an output

```
Options\Channel A
```

- Select the channel in the program branch `Options` (here: `Channel A`).
- Press ENTER.

This display will not be indicated if the transmitter has only one measuring channel.

- Select the list item `Outputs`.
- Press ENTER.

```
Options\Channel A\Outputs\Binary B1(--)
```

- Select the output to be assigned to the channel.
- Press ENTER.

If the channel has already been assigned to a channel, it is displayed as follows: `Binary B1 (A)`.

```
Options\Channel A\Outputs\Binary B1\B1 Enable
```

- Select `Yes` to change the settings for an already assigned output or to assign a new output.
- Select `No` to cancel the assignment and to return to the previous menu item.
- Press ENTER.

**Assignment of a source item**

Options\Channel A\Outputs\...\Source item

Depending on the selected source item, status or event values can be output.

Tab. 14.1: Output of status values or event values

	source item	status value	event value
physical quantities	Flow quantities	x	
	Fluid properties	x	
	Miscellaneous (Custom. Input 1...4)	x	
	Sound speed	x	
	Totalizers	x	
events	Event trigger		x

- Select the source item.
- Press ENTER.

**14.1.1 Definition of the switching function for the status/event value**

- Select the switching function for the output of the status/event value.
- Press ENTER.

Tab. 14.2: Selection of the switching condition

property	switching function	description
Status OK (status value)	NC	<ul style="list-style-type: none"> <li>• valid measured value: binary output is closed</li> <li>• invalid measured value: binary output is open</li> </ul>
	NO	<ul style="list-style-type: none"> <li>• valid measured value: binary output is open</li> <li>• invalid measured value: binary output is closed</li> </ul>
Idle state (event value)	NO	<ul style="list-style-type: none"> <li>• event occurs: binary output is closed</li> <li>• event has not occurred yet: binary output is open</li> </ul>
	NC	<ul style="list-style-type: none"> <li>• event occurs: binary output is open</li> <li>• event has not occurred yet: binary output is closed</li> </ul>

If no measurement is carried out, all binary outputs are open (de-energized), independent of the set switching condition.

**Terminal assignment**

Options\Channel A\Outputs\...\Output info

The terminals for the connection of the output are displayed.

By pressing **2** or **8** further information is displayed.

- Press ENTER.

**Output function test**

The function of the output can now be tested.

- Connect a multimeter to the output.

Options\Channel A\Outputs\...\B1 Test signal

- Select **Yes** to test the output. Select **No** to display the next menu item.
- Press ENTER.

```
Options\Channel A\Outputs\...\B1 Enter test value
```

- Select **On** to test the energized state of the output.
- Press **ENTER**.

The value has to be low ohmic.

- Select **Off** to test the de-energized state of the output.
- Press **ENTER**.

The value has to be high ohmic.

- Select **Repeat** to repeat the test, **Finish** to display the next menu item.
- Press **ENTER**.

```
Options\Channel A\Outputs\...\B1 Test mea. range
```

- Select **Yes** to test the status of the output signal. Select **No** to display the next menu item.
- Press **ENTER**.

```
Options\Outputs\...\B1 Enter test value
```

- Select **Passive** (idle state) or **Active** in case a event has been selected as source item.
- Press **ENTER**.

Depending on the selected switching condition, the value has to be either high or low ohmic.

- Select **Repeat** to repeat the test, **Finish** to display the next menu item.
- Press **ENTER**.

## 14.2 Activation of a binary output as pulse output

A pulse output is an integrating output which emits a pulse when the volume or the mass of the fluid which has passed the measuring point, reaches a certain value (pulse value).

The integrated quantity is the selected physical quantity. The integration is restarted as soon as the pulse is emitted. Before the activation, the binary output has to be configured.

### Notice!

The activation of a binary output as pulse output is only possible for binary outputs supporting a pulse output.

```
Options\Channel A\Outputs\Binary B1
```

- Select the list item **Binary B1** in the menu item **Outputs**.
- Press **ENTER**.

```
Options\Channel A\Outputs\Binary B1\Source item\Pulse
```

- Select the list item **Pulse** in the menu item **Source item**.
- Press **ENTER**.

```
Options\Channel A\Outputs\Binary B1\Source item\Pulse\Pulse +V
```

- Select a list item (here: **Pulse +V**).
- Press **ENTER**.

```
Options\Channel A\Outputs\Binary B1\Source item\Pulse\Pulse value
```

- Enter the pulse value.

The unit of measurement will be displayed according to the actual physical quantity.

When the counted physical quantity reaches the entered pulse value, a pulse will be transmitted.

- Press ENTER.

```
Options\Channel A\Outputs\Binary B1\Source item\Pulse\Pulse width
```

- Enter the pulse width.

The range of possible pulse widths depends on the specification of the instrument (e.g., counter, PLC) that is to be connected to the output.

- Press ENTER.

### Terminal assignment

```
Options\Channel A\Outputs\...\Output info
```

The terminals for the connection of the output are displayed.

By pressing  or  further information is displayed.

- Press ENTER.

## 14.3 Activation of a frequency output as pulse output

```
Options\Channel A\Outputs\Frequency F1
```

- Select the list item `Frequency F1` in the menu item `Outputs`.
- Press ENTER.

```
Options\Channel A\Outputs\Frequency F1\Source item\Pulse
```

- Select the list item `Pulse` in the menu item `Source item`.
- Press ENTER.

```
Options\Channel A\Outputs\Frequency F1\Source item\Pulse\Pulse +V
```

- Select a list item (here: `Pulse +V`).
- Press ENTER.

```
Options\...\Frequency F1\Source item\Pulse\F1 Output range
```

- Select a list item:

- 0...1 kHz
- 0...5 kHz
- Other range

- Press ENTER.

If `Other range` is selected, enter a value for `Output MAX`.

```
Options\...\Frequency F1\Source item\Pulse\F1 Output range\Pulses per unit
```

- Enter the number of pulses per unit.
- Press ENTER.

The unit of measurement will be displayed according to the actual physical quantity.

## Terminal assignment

Options\...\Frequency F1\...\Output info

The terminals for the connection of the output are displayed.

By pressing  or  further information is displayed.

- Press  twice.

The max. value of the physical quantity is displayed.

- Press ENTER.

The pulse output emits a frequency resulting from the physical quantity of the fluid passing at the measuring point and the entered number of pulses per unit.

## Example

pulse: Pulse +V

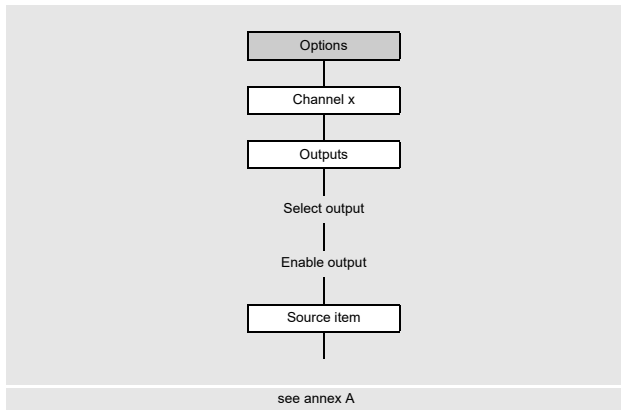
output range: 0...1 kHz

pulses per unit: 100/m<sup>3</sup>

5 m<sup>3</sup> of the fluid are passing at the measuring point. A frequency of 0.5 kHz is transmitted at the pulse output.

display: Maximum 36000.00 m<sup>3</sup>/h

## 15 Outputs (TF7-\*72\*\*\*-\*\*\*\*\*-\*\*\*\*\*a-\*\*\*\*\*-\*\*, a = M, P, Q)



If the transmitter is equipped with outputs, they have to be configured. For the configuration of the analog output, see section 9.2.6.

The transmitter can also be equipped with digital outputs. A digital output combines the functions of the following outputs:

- binary output (output of binary switching conditions)
- pulse output (integrating output of quantities)
- frequency output (scaled output of flow quantities)

These functions depend on the selected physical quantity.

Tab. 15.1: Output via digital outputs

	source item	binary output		pulse output	frequency output
		status value	event value		
physical quantities	Flow quantities	x			x
	Totalizers	x			x
	Pulse			x	
	Fluid properties	x			x
	Diagnostic values (Crest factor)				x
	Miscellaneous (Custom. Input 1...4)	x			x
events	Event trigger		x		

### 15.1 Configuration of a digital output as binary output

A digital output switches if one of the following switching conditions is met:

- the measured value exceeds or falls below a limit
- the measured value lays within or outside a defined range
- a measurement is not possible
- an event occurs

#### Assignment of an output

```
Options\Channel A
```

- Select the channel in the program branch Options (here: Channel A).
- Press ENTER.

This display will not be indicated if the transmitter has only one measuring channel.

- Select the list item Outputs.
- Press ENTER.

```
Options\Channel A\Outputs\Digital output B1(--)
```

- Select an output to be assigned to the channel (here: Digital output B1).
- Press ENTER.

If the output has already been assigned to a channel, it is displayed as follows: Digital output B1 (A).



Options\Channel A\Outputs\Digital output B1\Enable B1

- Select **Yes** to change the settings for an already assigned output or to assign a new output.
- Select **No** to cancel the assignment and to return to the previous menu item.
- Press **ENTER**.

**Assignment of a source item**

Options\Channel A\Outputs\...\Source item

Depending on the selected source item, status or event values can be output.

Tab. 15.2: Output of status values or event values

	source item	status value	event value
physical quantities	Flow quantities	x	
	Fluid properties	x	
	Miscellaneous (Custom. Input 1...4)	x	
	Sound speed	x	
	Totalizers	x	
events	Event trigger		x

- Select the source item.
- Press **ENTER**.
- Select the list item **Status**.
- Press **ENTER**.

If **Event trigger** is selected as source item, **Idle state** will be displayed as property of the binary output.

**15.1.1 Definition of the switching function for the status/event value**

- Select the switching function for the output of the status/event value.
- Press **ENTER**.

Tab. 15.3: Selection of the switching condition

property	switching function	description
Status OK (status value)	NC	<ul style="list-style-type: none"> <li>• valid measured value: binary output is closed</li> <li>• invalid measured value: binary output is open</li> </ul>
	NO	<ul style="list-style-type: none"> <li>• valid measured value: binary output is open</li> <li>• invalid measured value: binary output is closed</li> </ul>
Idle state (event value)	NO	<ul style="list-style-type: none"> <li>• event occurs: binary output is closed</li> <li>• event has not occurred yet: binary output is open</li> </ul>
	NC	<ul style="list-style-type: none"> <li>• event occurs: binary output is open</li> <li>• event has not occurred yet: binary output is closed</li> </ul>

If no measurement is carried out, all binary outputs are open (de-energized), independent of the set switching condition.

**Terminal assignment**

Options\Channel A\Outputs\...\Output info

The terminals for the connection of the output are displayed.

By pressing  or  further information is displayed.

- Press ENTER.

**Output function test**

The function of the output can now be tested.

- Connect a multimeter to the output.

Options\Channel A\Outputs\...\B1 Test signal

- Select **Yes** to test the output. Select **No** to display the next menu item.
- Press ENTER.

Options\Channel A\Outputs\...\B1 Enter test value

- Select a list item as test value.
- Press ENTER.

Tab. 15.4: Output function test – signal

list item	description
NC	<ul style="list-style-type: none"> <li>• binary output is energized</li> <li>• measured value has to be low ohmic</li> </ul>
NO	<ul style="list-style-type: none"> <li>• binary output is de-energized</li> <li>• measured value has to be high ohmic</li> </ul>

- Select **Repeat** to repeat the test or **Finish** to display the next menu item.
- Press ENTER.

Options\Channel A\Outputs\...\B1 Test mea. range

- Select **Yes** to test the status of the output signal. Select **No** to display the next menu item.
- Press ENTER.

Options\Channel A\Outputs\...\B1 Enter test value

- Select a list item as test value.
- Press ENTER.

Tab. 15.5: Output function test – measuring range

list item	switching function	test value	description
Status OK (status value)	NC	Status OK	<ul style="list-style-type: none"> <li>binary output is energized</li> <li>measured value has to be low ohmic</li> </ul>
		Status error	<ul style="list-style-type: none"> <li>binary output is de-energized</li> <li>measured value has to be high ohmic</li> </ul>
	NO	Status OK	<ul style="list-style-type: none"> <li>binary output is de-energized</li> <li>measured value has to be high ohmic</li> </ul>
		Status error	<ul style="list-style-type: none"> <li>binary output is energized</li> <li>measured value has to be low ohmic</li> </ul>
Idle state (event value)	NC	Passive	<ul style="list-style-type: none"> <li>binary output is energized</li> <li>measured value has to be low ohmic</li> </ul>
		Active	<ul style="list-style-type: none"> <li>binary output is de-energized</li> <li>measured value has to be high ohmic</li> </ul>
	NO	Passive	<ul style="list-style-type: none"> <li>binary output is de-energized</li> <li>measured value has to be high ohmic</li> </ul>
		Active	<ul style="list-style-type: none"> <li>binary output is energized</li> <li>measured value has to be low ohmic</li> </ul>

- Select `Repeat` to repeat the test or `Finish` to display the next menu item.
- Press `ENTER`.

## 15.2 Configuration of a digital output as pulse output

A pulse output is an integrating output which emits a pulse when the volume or the mass of the fluid which has passed the measuring point reaches a certain value (pulse value).

The integrated quantity is the selected physical quantity. The integration is restarted as soon as the pulse is emitted. Before the activation, the digital output has to be configured.

```
Options\Channel A\Outputs\Digital output
```

- Select the menu item `Options\Channel A\Outputs\Digital output`.
- Press `ENTER`.

### Assignment of a source item

```
Options\Channel A\Outputs\Digital output B1\Source item\Pulse
```

- Select `Pulse` as source item.
- Press `ENTER`.

```
Options\Channel A\Outputs\Digital output B1\Source item\Pulse\Pulse +V
```

- Select a list item (here: `Pulse +V`):
- Press `ENTER`.

Tab. 15.6: Selection of the physical quantity

source item	list item	output
Pulse	Pulse  V	pulse without considering the sign of the volumetric flow rate
	Pulse +V	pulse for positive measured values of the volumetric flow rate
	Pulse -V	pulse for negative measured values of the volumetric flow rate
	Pulse  m	pulse without considering the sign of the mass flow rate
	Pulse +m	pulse for the positive measured values of the mass flow rate
	Pulse -m	pulse for the negative measured values of the mas flow rate

### 15.2.1 Pulse output by defining the pulse value

Options\Channel A\Outputs\Digital output B1\Source item\Pulse\Pulse output

- Select Pulse output.
- Press ENTER.

Options\Channel A\Outputs\Digital output B1\...\Pulse mode

The pulse output can be operated in 2 modes:

mode	description
Continuous pulses	<ul style="list-style-type: none"> <li>• output of a continuous pulse sequence, reproducing the temporal behavior of the corresponding flow quantity (volumetric flow rate, mass flow rate), at simultaneous totalizing</li> <li>• smallest pulse break = pulse width at max. pulse rate (pulse width is constant)</li> </ul>
Burst pulses	<ul style="list-style-type: none"> <li>• output of a discontinuous pulse sequence, reproducing the behavior of the totalizer</li> <li>• several pulses can arise intermittently with equidistant pulse distances (pulse break = pulse width)</li> <li>• serves exclusively for totalizing</li> <li>• max. pulse rate (depends on the pulse width that is constant)</li> </ul>

- Select a mode.
- Press ENTER.

Options\Channel A\Outputs\Digital output B1\...\Pulse mode\Pulse value

- Enter the pulse value.

The unit of measurement will be displayed according to the actual physical quantity.

When the counted physical quantity reaches the entered pulse value, a pulse will be transmitted.

- Press ENTER.

Options\Channel A\Outputs\Digital output B1\...\Pulse mode\Pulse width

- Enter the pulse width.

The range of possible pulse widths depends on the specification of the instrument (e.g., counter, PLC) that is to be connected to the output.

- Press ENTER.

### 15.2.2 Pulse output by defining pulses per unit

Options\Channel A\Outputs\Digital output B1\Source item\Pulse\Pulse output

- Select Pulses per unit.
- Press ENTER.

Options\Channel A\Outputs\Digital output B1\...\Output range B1

- Select a list item:
  - 0...1 kHz
  - 0...5 kHz
  - Other range

- Press ENTER.

If Other range is selected, enter a value for Output MAX.

Options\Channel A\Outputs\Digital output B1\...\Pulses per unit

- Enter the number of pulses per unit.
- Press ENTER.

The unit of measurement will be displayed according to the actual physical quantity.

### 15.2.3 Output options

Options\Channel A\Outputs\Digital output B1\Source item\Pulse\...\Idle state

- Select the setting of the idle state:

setting	description
NO	The pulse output is energized if a pulse is emitted and de-energized if no pulse is emitted (idle state).
NC	The pulse output is de-energized if a pulse is emitted and energized if no pulse is emitted (idle state).

### Terminal assignment

Options\Channel A\Outputs\Digital output B1\...\Output info

The terminals for the connection of the output are displayed.

By pressing 2 or 8 further information is displayed.

- Press ENTER.

### Output function test

Options\Channel A\Outputs\...\B1 Test signal

- Select Yes to test the status of the output signal. Select No to display the next menu item.
- Press ENTER.

Options\Channel A\Outputs\...\B1 Enter test value

- Select a list item as test value.
- Press ENTER.

Tab. 15.7: Output function test – signal

output mode	test value	description
Pulses per unit	The entered test value has to be within the output range.	If the external measuring instrument displays the entered value, the output functions correctly.
Pulse value	NO	<ul style="list-style-type: none"> <li>• pulse output is de-energized</li> <li>• measured value has to be high ohmic</li> </ul>
	NC	<ul style="list-style-type: none"> <li>• pulse output is energized</li> <li>• measured value has to be low ohmic</li> </ul>

### 15.3 Configuration of a digital output as frequency output

The frequency output emits a square wave signal with a frequency which is proportional to the measured value of the source item sent to the output.

#### Assignment of a source item

Options\Channel A\Outputs\Digital output B1\Source item

- Select one of the following source items:
  - Flow quantities
  - Totalizers
  - Fluid properties
  - Diagnostic values
  - Miscellaneous (Custom. Input 1...4)
  - Sound speed

Options\Channel A\Outputs\Digital output B1\Source item\Flow quantities

- Select a list item (here: Flow quantities).
- Press ENTER.

Options\Channel A\Outputs\Digital output B1\Source item\...\Volumetric flow rate

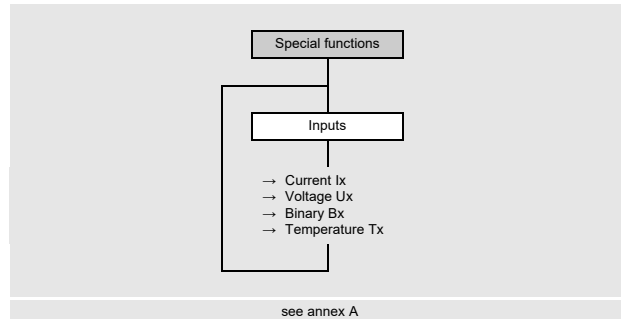
- Select a list item (here: Volumetric flow rate).
- Press ENTER.
- Select Values.
- Press ENTER.
- Pass the menu item Options\...\Outputs in its entirety:
  - output range
  - error value
  - measuring range
  - output info
  - function test

For the description of the individual steps, see section 9.2.6.

## 16 Inputs

The inputs are configured in the program branch `Special functions` and assigned to the individual measuring channels in the program branch `Options`.

### 16.1 Configuration of an input



If the transmitter is equipped with inputs, they have to be configured.

- Select the program branch `Special functions`.
- Press ENTER.

```
Special functions\Inputs
```

- Select the input to be configured.
- Press ENTER.

The scroll list contains all available inputs.

- Select a list item:
  - Current Ix (-)
  - Voltage Ux (-)
  - Binary Bx (-)
  - Temperature Tx (-)

If the input has already been configured, it is displayed as follows: `Current I1 (✓)`.

#### Enabling the input

To use the input, it has to be enabled (here: `Current I1`)

```
Special functions\Inputs\Current I1\I1 Enable
```

- Select `Yes` to enable an input or change the settings for an already enabled input.
- Select `No` to uninstall an already configured input and to return to the previous menu item.
- Press ENTER.

#### 16.1.1 Current and voltage inputs

When configuring the current or voltage inputs, the source item can now be selected and the input and measuring range is defined.

##### Selection of the source item

```
Special functions\Inputs\...\Source item
```

- Select the source item.

##### Input range

Now the input range is defined.

```
Special functions\Inputs\...\Input range
```

- Select a list item:
  - 0...20 mA
  - 4...20 mA
  - Other range

- Press ENTER.

If `Other range` is selected, enter the values `Input MIN` and `Input MAX`.

## Measuring range

```
Special functions\Inputs\...\Start of meas. range
```

- Enter the lowest expected measured value. The unit of measurement of the source item will be displayed. `Start of meas. range` is the physical quantity assigned to the lower limit of the input range (`Input MIN`).
- Enter the highest expected measured value. The unit of measurement of the source item will be displayed. `End of meas. range` is the physical quantity assigned to the higher limit of the input range (`Input MAX`).

## Input of an error value

```
Special functions\Inputs\...\Error value
```

It is possible to define an error value which is output if the source item is not available.

- Select `Yes` if an error value is to be defined.
- Press `ENTER`.
- Enter the error value.
- Press `ENTER`.

### 16.1.2 Temperature inputs

When configuring the temperature input, the temperature probe can now be selected.

#### Selection of the temperature probe

```
Special functions\Inputs\Temperature Tx\Pt100/Pt1000
```

- Select the temperature probe:
  - `Pt100`
  - `Pt1000`

#### Activation of the temperature correction

A temperature correction (offset) can be set for each temperature input. This function is activated in the menu item `Special version\Dialogs/Menu`.

```
Special functions\Dialogs/Menu\Tx temperature offset
```

- Select `Yes` to activate the temperature correction. Select `No` to deactivate it.
- Press `ENTER`.

#### Notice!

The entered correction value for each temperature input will be stored and displayed when the temperature correction is activated again.

The correction value is automatically added to the measured temperature. It is used e.g., if the characteristic curves of the two temperature probes differ considerably from each other or a known and constant temperature gradient exists between the measured temperature and the actual temperature.

#### Input of the temperature correction

```
Special functions\Inputs\Temperature Tx\Temperature offset
```

- Enter the offset for the temperature input.
- Press `ENTER`.



### 16.1.3 Definition of a switching condition

If a transmitter function is to be performed by remote control, a switching condition has to be defined.

Special functions\Inputs\...\Trigger value

- Select **Yes** if a switching condition is to be defined. Select **No** to display the next menu item.
- Press **ENTER**.

Special functions\Inputs\...\Function

- Select a list item:
  - **MAX** ( $x > \text{limit}$ ): the switching condition is met when the measured value exceeds the limit
  - **MIN** ( $x < \text{limit}$ ): the switching condition is met when the measured value falls below the limit
  - **ERR** ( $x = \text{fail}$ ): the switching condition is met when a measurement is not possible
  - **Within range**: the switching condition is met when the measured value is within the defined range.
  - **Out of range**: the switching condition is met when the measured value is outside the defined range
- Press **ENTER**.

Special functions\Inputs\...\Trigger value

- Enter the limit for the switching condition.
  - Press **ENTER**.
- This display will only be indicated if **MAX** ( $x > \text{limit}$ ) or **MIN** ( $x < \text{limit}$ ) is selected.

Special functions\Inputs\...\Hysteresis

It is possible to define a hysteresis to avoid constant switching of the event trigger.

The event trigger is activated when the measured value exceeds the upper limit and deactivated when it falls below the lower limit.

- Enter the value for the hysteresis.
- If zero is entered, no hysteresis is used.
- Press **ENTER**.

This display will only be indicated if **MAX** ( $x > \text{limit}$ ) or **MIN** ( $x < \text{limit}$ ) is selected.

Special functions\Inputs\...\Range center

- Enter the center of the switching range.
- Press **ENTER**.

This display will only be indicated if **Within range** or **Out of range** is selected.

Special functions\Inputs\...\Range width

- Enter the width of the switching range.
- Press **ENTER**.

This display will only be indicated if **Within range** or **Out of range** is selected.

Special functions\Inputs\...\Glitch interval

- Enter a time interval at the end of which the event trigger has to switch.
- Press **ENTER**.

### 16.1.4 Binary inputs

The transmitter can be equipped with max. 4 binary inputs. Via the binary inputs, it is possible to remotely trigger some functions of the transmitter.

#### Inversion of the input

```
Special functions\Inputs\Binary Bx\Negate input
```

- Select **Yes** if a function is to be triggered when no voltage is existing (negated logic).
- Select **No** if a function is to be triggered when voltage is existing.

### 16.1.5 Terminal assignment

```
Special functions\Inputs\...\Input info
```

The terminals for the connection of the input are displayed.

By pressing **2** or **8** further information is displayed.

- Press **ENTER**.

### 16.1.6 Function test of the input

The function of the installed input can now be tested.

#### Analog input

- Connect the signal source to the input.

```
Special functions\Inputs\...\I1 Test signal
```

- Select **Yes** to test the input signal. Select **No** to display the next menu item.
- Press **ENTER**.

```
Special functions\Inputs\...\I1 Test signal\Current
```

- If the transmitter displays a value (here: **Current**), the input functions correctly.
- Press **ENTER**.
- Select **Repeat** to repeat the test or **Finish** to display the next menu item.
- Press **ENTER**.

```
Special functions\Inputs\...\I1 Test mea. range
```

- Select **Yes** to test the assignment of the measured value to the input signal. Select **No** to display the next menu item.
- Press **ENTER**.

```
Special functions\Inputs\...\I1 Test mea. range\Temperature
```

- If the transmitter displays a value (here: **Temperature**), the input functions correctly.
- Press **ENTER**.
- Select **Repeat** to repeat the test or **Finish** to display the next menu item.
- Press **ENTER**.


### Binary input

- Connect the signal source to the input.

```
Special functions\Inputs\...\I1 Test signal
```

- Select **Yes** to test the input signal. Select **No** to display the next menu item.
- Press **ENTER**.

If the transmitter displays that a input signal is connected, the input functions correctly.

- Press  to return to the main menu.

## 16.2 Assignment of an input

- Select the program branch **Options**.
- Press **ENTER**.

```
Options\Channel ...
```

- Select the channel.
- Press **ENTER**.

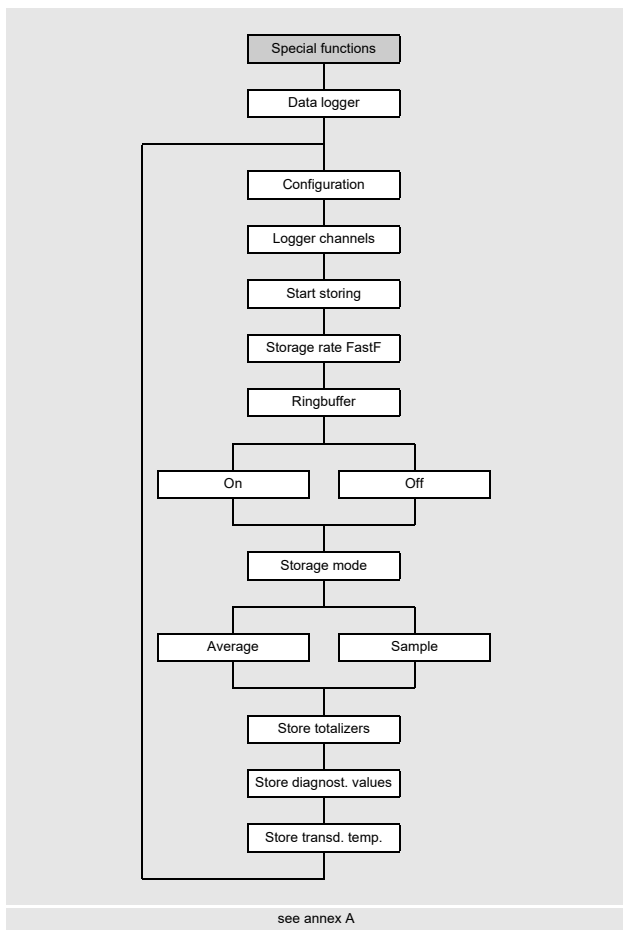
This display will not be indicated if the transmitter has only one measuring channel.

- Select **Assign inputs**.
- Press **ENTER**.

```
Options\Assign inputs
```

- Select the input to be assigned to the channel. Only the installed inputs are displayed in the scroll list.
- Select the list item **No linkage** if no input is to be assigned to the channel.
- Press **ENTER**.

## 17 Data logger



The transmitter has a data logger which stores the measured values during the measurement.

**Notice!**  
In order to store measured data, the data logger has to be configured.

The following data can be stored:

- date
- time
- measuring point number
- pipe parameters
- fluid parameters
- transducer data
- physical quantity
- unit of measurement
- measured values

Measured values transmitted via the outputs are also stored in the data logger.

If the pulse values are transmitted via an output, the corresponding flow quantity and the totalizer value are stored in the data logger. In case of absolute pulse values, the values of both totalizers are stored.

### 17.1 Configuration of the data logger

#### Activation of the channels for storing

```
Special functions\Data logger\Configuration\Logger channels
```

- Select the menu item `Configuration`.
- Press `ENTER`.
- Activate the channels whose measured values have to be stored.
- Press `4` or `6` to select a channel.
- Press `2` to activate/deactivate a channel.
- Press `ENTER`.

#### Starting time

```
Special functions\Data logger\Configuration\Start storing
```

It is possible to set a starting time if it is necessary to synchronize the storing of measured values for several transmitters.

- Select the menu item `Configuration`.
- Press `ENTER` until the menu item `Start storing` is displayed.
- Select the moment at which to start the storing.

display	description
Immediately	The storing starts immediately.
Full 5 minutes	The storing starts in the next full 5 minutes.
Full 10 minutes	The storing starts in the next full 10 minutes.
Full 15 minutes	The storing starts in the next full 15 minutes.
Full 30 minutes	The storing starts in the next full 30 minutes.
Full hour	The storing starts in the next full 60 minutes.
Event-based	The storing starts when a defined event occurs.

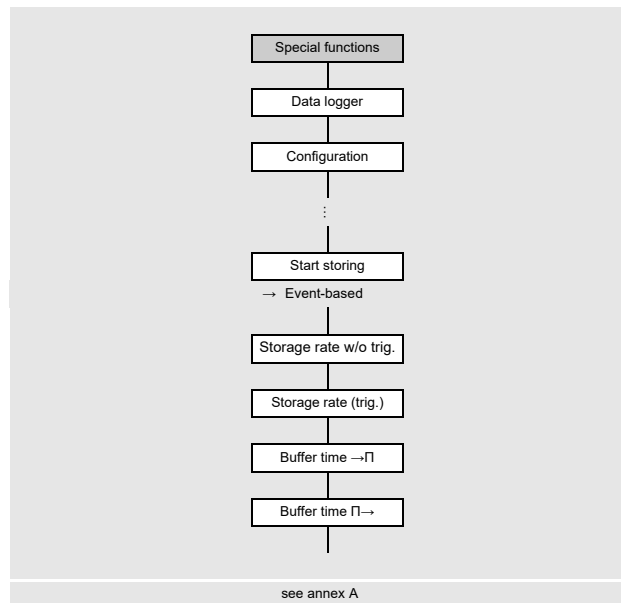
### Example

actual time: 09:06 am  
 setting: Full 10 minutes  
 The storing starts at 09:10 am.

### Notice!

Make sure that the time of all transmitters is synchronized.

### Event-based starting time



```
Special functions\Data logger\  
Configuration\Start storing\Event-based
```

If it is necessary to start the storing of measured values at a particular event, select **Event-based** as starting time. The event is signaled via an input or event trigger. All configured inputs and event triggers are displayed in the scroll list.

- Select the input or the event trigger through which the event is to be signaled.
- Press ENTER.

```
Special functions\Data logger\  
Configuration\Start storing\Event-based\  
Storage rate w/o trig.
```

The storage rate is the frequency to transmit or store measured values.

- Select in the scroll list a storage rate for storing the measured values in case the event does not occur.
- Press ENTER.
- Select **Off** if no measured values are to be stored, as long as the event does not occur.
- Press ENTER.

```
Special functions\Data logger\Configuration\Start storing\Event-based\  
Storage rate (trig.)
```

- Select in the scroll list a storage rate for storing the measured values in case the event occurs.
- Press ENTER.

```
Special functions\Data logger\Configuration\Start storing\Event-based\  
Buffer time ->Π
```

- Enter the time interval for the measured values to be stored before the event occurs.
- Press ENTER.

```
Special functions\Data logger\Configuration\Start storing\Event-based\  
Buffer time Π->
```

- Enter the time interval for the measured values to be stored if the event is no longer activated.
- Press ENTER.

### Storage rate

```
Special functions\Data logger\Configuration\Storage rate
```

The storage rate is the frequency to transmit or store measured values. If a start time for storing the measured values is defined, a storage rate has to be entered.

- Select the menu item `Configuration`.
- Press ENTER until the menu item `Storage rate` is displayed.
- Select a storage rate from the scroll list.
- Press ENTER.
- If `Customized` is selected, enter the storage rate.
- Press ENTER.

### Storage rate of the FastFood mode

The the storage rate of the FastFood mode is the frequency at which the measured values are stored in the FastFood mode.

```
Special functions\Data logger\Configuration\Storage rate FastF
```

This display will only be indicated if the FastFood mode has been activated in the menu item `Special functions\Measurement\Measurement modes`.

- Select the menu item `Configuration`.
- Press ENTER until the menu item `Storage rate FastF` is displayed.
- Select `Automatic` if the storage rate has to correspond to the value of the FastFood measuring rate.
- Press ENTER.
- Select `Customized` if the value for the storage rate is to be defined.
- Press ENTER.
- Enter a value.
- Press ENTER.

### Ringbuffer

Special functions\Data logger\Configuration\Ringbuffer

The data logger can be configured as linear logger or ringbuffer. If the ringbuffer is deactivated and the data logger is full, the storing of measured values will be terminated. It can be continued after clearing the data logger. If the ringbuffer is activated and the data logger is full, the oldest measured values will be overwritten. In ringbuffer mode, the remaining capacity of the data logger is displayed during the measurement, e.g.:

Log→ : 1d 6h 57m is displayed, if no measured values have been overwritten.

Log|←| : 1d 6h 57m is displayed, if the old measured values have been overwritten.

- Select the menu item `Configuration`.
- Press ENTER until the menu item `Ringbuffer` is displayed.
- Select `On` to activate the ringbuffer.
- Press ENTER.

If the ringbuffer is deactivated and the data logger is full, the storing of measured values will be terminated.

- Select `Off` to deactivate the ringbuffer.
- Press ENTER.

### Storage mode

Special functions\Data logger\Configuration\Storage mode

- Select the menu item `Configuration`.
- Press ENTER until the menu item `Storage mode` is displayed.
- Press ENTER.
- Select `Sample` to store the current measured value.
- Select `Average` if the average of all undamped measured values of a storage interval is to be stored.

#### Notice!

The storage mode does not affect the outputs.

#### Notice!

Storage mode = Average

The average of the physical quantity and of other quantities assigned to the measuring channel, e.g., the measured temperature, will be calculated.

If a storage rate < 5 s is selected, `Sample` will be used.

If no average could be calculated over the complete storage interval, the value will be marked as invalid.

### Further parameters for storing

It can be defined whether the following parameters are to be stored together with the measured values.

Tab. 17.1: Parameters for storing

display	description of the parameters
Store totalizers	values of the totalizers
Store diagnost. values	diagnostic values
Store transd. temp.	transducer temperature

- Select `Yes` to store the value. Select `No` in order not to store the value.

## 17.2 Deletion of the data logger

Special functions\Data logger>Delete meas. values

- Select the menu item Delete meas. values.
- Press ENTER.
- Select Yes or No.
- Press ENTER.

## 17.3 Information regarding the data logger

Special functions\Data logger\Data logger info

- Select the menu item Data logger info.
- Press ENTER.

The following information regarding the data logger is displayed:

display	description
Activated	data logger is activated/deactivated This display will only be indicated if the measurement has started and the data logger is activated.
Full (date)	date on which the data logger will be full This display will only be indicated if the measurement has started and the ringbuffer is deactivated.
Full (time)	time at which the data logger will be full This display will only be indicated if the measurement has started, the ringbuffer is deactivated and the data logger is not full yet.
Overflow (date)	date from which the oldest measured values will be overwritten This display will only be indicated if the measurement has started, the ringbuffer is activated and the data logger is not full yet.
Capacity (time)	remaining data logger capacity This display will only be indicated if the measurement has started and the ringbuffer is activated.
Ringbuffer	ringbuffer is activated/deactivated
Meas. val. series	number of stored series of measured values
Occup. logger	percentage of memory actually used

## 17.4 Print of measured values

- Start the terminal program.
- Enter the transmission parameters into the terminal program. The transmission parameters of the terminal program and the transmitter have to be identical.

Special functions\Data logger\Print meas. values

- Select the menu item Print meas. values.  
This display will only be indicated if the transmitter has an interface RS485.
- Press ENTER.



## 17.5 Transmission settings

Special functions\Data logger\Transmission settings\Serial output channel

- Select the menu item `Transmission settings`.

This display will only be indicated if the transmitter has an interface RS485.

- Press ENTER.

The channels for the serial transmission can be activated and deactivated.

- the channel is activated
- the channel is deactivated

- Select a channel with `<4>` or `<6>`.
- Press `<2>` or `<8>` to activate or deactivate the channel.
- Press ENTER.

Special functions\Data logger\Transmission settings>Delete spaces

- Select `On` if the space characters are not to be transmitted.
- Press ENTER.

The file size will be considerably reduced (shorter transmission time).

Special functions\Data logger\Transmission settings\Decimal marker

- Select the decimal marker to be used for floating-point numbers (point or comma).
- Press ENTER.

This setting depends on the setting of the operating system of the PC.

Special functions\Data logger\Transmission settings\Column separator

- Select the character to be used to separate columns (semicolon or tabulator).
- Press ENTER.

Special functions\Data logger\Transmission settings>Date/time

- Select `Yes` to transmit time and date.
- Press ENTER.

## 18 Data transmission

The data is transmit via the service interfaces or the process interface (optional) of the transmitter.

### 18.1 Service interfaces

By means of the program FluxDiagReader it is possible to transmit via service interfaces (USB, LAN) data to the PC.

The following tasks can be carried out:

- read and store measured values, setup settings and snaps
- graphically display measured values
- export of data in csv format

For the operation of FluxDiagReader see the help function of this program.

#### 18.1.1 LAN interface

In order to use the LAN interface it is important to enter the network parameters.

- Select the program branch `Special functions`.
- Press ENTER.

```
Special functions\Communication\Network
```

- Select the menu item `Special functions\Communication\Network`.
- Press ENTER.

#### Manual input

- Select `Manual` to enter the network parameter (IP address, subnet mask and standard gateway).

#### Notice!

The entered network parameters have to accord with the network parameters of the LAN.

Default values in the transmitter:

- IP address: 192.168.0.70
- subnet mask: 255.255.255.0
- standard gateway: 192.168.0.1

#### Automatic addressing with DHCP

- Select `Automatic` to automatically identify the network parameters (IP address, subnet mask and gateway address) via a DHCP server.

#### Notice!

The network parameters can only be automatically identified if the LAN supports DCHP.

- Select the menu item `Special functions\Communication\Network\Show auto config`, to display the identified network parameters.
- Press ENTER.

#### Notice!

To transmit data from the PC to the transmitter, the program FluxDiag has to be used.

## 18.2 Process interface

The transmitter can be equipped with a process interface (e.g., Profibus, Modbus). For the connection of the process interface to the transmitter see supplement to operating instruction.

### RS485 interface

```
Special functions\Communication\RS485
```

- Select the menu item RS485 to change the settings of the transmission parameters.
- Press ENTER.

This display will only be indicated if the transmitter has an interface RS485.

default: 9600 bit/s, 8 data bits, no parity, 1 stop bit

- Set the transmission parameters in the scroll lists.
  - Baud (baud rate)
  - Data bits
  - Stop bits
  - Parity
  - Data flow control
- Press ENTER.

```
Special functions\Communication\Info RS485
```

The terminals for the connection of the RS485 interface are displayed.

- Press ENTER.

## 19 Advanced functions








### 19.1 Totalizers

The thermal energy, total volume or total mass of the fluid at the measuring point can be determined.

There are 2 totalizers, one for the positive and the other for the negative flow direction. The unit of measurement used for totalizing corresponds to the heat, volume or mass unit selected for the physical quantity.

The totalizer values can be displayed in the status line during the measurement.

Tab. 19.1: Key functions

totalizer display	press  during the measurement
freezing of the displayed totalizer value	press  for at least 2 s during the measurement
display of the totalizer for the positive flow direction	press  during the measurement
display of the totalizer for the negative flow direction	press  during the measurement
reset of the totalizers to zero	press  3 times during the measurement totalizing will be restarted after pressing 
	press  3 times during the measurement totalizing will be restarted and displayed immediately

#### Notice!

The pressing of a key will only influence the totalizers of the measuring channel whose measured values are currently displayed.

#### 19.1.1 Number of decimal places

The values of the totalizers can be displayed with up to 11 places, e.g., 74890046.03. The number of decimal places (max. 4) can be defined.

Special functions\Totalizers

- Select the menu item `Totalizers` in the program branch `Special functions`.
- Press ENTER.
- Select `Automatic` if the number of decimal places has to be adjusted automatically.
- Press ENTER.

Low totalizer values will initially be displayed with 3 decimal places. If the values of the totalizers are higher, the number of decimal places will be reduced.

max. value	display
$< 10^6$	±0.000                      ...                      ±999999.999
$< 10^7$	±1000000.00                      ...                      ±9999999.99
$< 10^8$	±10000000.0                      ...                      ±99999999.9
$< 10^{10}$	±1000000000                      ...                      ±9999999999

- Select the number of decimal places.
- Press ENTER.

The number of decimal places is constant. The max. value of the totalizers decreases with an increasing number of decimal places.

decimal places	max. value	max. display
0	$< 10^{10}$	±9999999999
1	$< 10^8$	±99999999.9
2	$< 10^7$	±9999999.99
3	$< 10^6$	±999999.999
4	$< 10^5$	±99999.9999

**Notice!**

The number of decimal places and the max. value of the totalizers only affect the display.

**19.1.2 Detection of long measurement failures**

If there are no valid measured values during a long time interval, the totalizers remain unchanged. Behind this value an interrogation point will be displayed.

The time interval can be defined.

Special functions\Totalizers\Totalizer timeout

- Select the menu item `Totalizers` in the program branch `Special functions`.
- Press ENTER until the menu item `Totalizer timeout` is displayed.
- Select `Default` if no customized inputs are to be carried out and the default value of 30 s is to be used.
- Press ENTER.
- Select `Customized` if the time interval is to be defined.
- Press ENTER.
- Enter the time interval.
- Press ENTER.

**19.1.3 Totalizer overflow**

The overflow behavior of the totalizers can be set:

**Without overflow**

- The totalizer value increases up to the internal limit of  $10^{38}$ .
- The values will be displayed as exponential numbers ( $\pm 1.00000E10$ ), if necessary. The totalizer can only be reset to zero manually.

**With overflow**

The totalizer will be automatically reset to zero when reaching  $\pm 9999999999$ .

Special functions\Totalizers\Overflow behavior

- Select the menu item `Totalizers` in the program branch `Special functions`.
- Press ENTER until the menu item `Overflow behavior` is displayed.
- Select `Yes` to work with overflow. Select `No` to work without overflow.
- Press ENTER.

Independent of the setting, the totalizers can be reset to zero manually.

**Notice!**

The overflow of a totalizer influences all output channels, e.g., the data logger and the online transmission of data. The sum of both totalizers (throughput  $\Sigma Q$ ) transmitted via an output is no longer valid after one of the totalizers has overflowed for the first time.

#### 19.1.4 Totalizer behavior after the measurement is stopped

It is possible to define the totalizer behavior after the measurement is stopped or after a reset of the transmitter.

```
Special functions\Totalizers\Keep totalizers
```

- Select the menu item `Totalizers` in the program branch `Special functions`.
- Press ENTER until the menu item `Keep totalizers` is displayed.
- Select `Yes` if the values of the totalizers are to be stored and used for the next measurement. Select `No` if the totalizers are to be set to zero.
- Press ENTER.

#### 19.1.5 Totalizer behavior during the thermal energy rate measurement

During the thermal energy rate measurement, it is possible to output and store the values the thermal energy totalizer and of the volume totalizer.

```
Special functions\Totalizers\Therm.ener.+flow tot.
```

- Select the menu item `Totalizers`.
- Press ENTER until the menu item `Therm.ener.+flow tot.` is displayed.
- Select `Yes` if the values of the thermal energy totalizer and the volume totalizer are to be stored and output during the thermal energy measurement.
- Press ENTER.

#### 19.1.6 Totalizer sum

The sum of the totalizers for both flow directions can be displayed in the status line during the measurement.

```
Special functions\Totalizers>Show  $\Sigma Q$ 
```

- Select the menu item `Totalizers` in the program branch `Special functions`.
- Press ENTER until the menu item `Show  $\Sigma Q$`  is displayed.
- Select `Yes` to display the totalizer sum. Select `No` if it is not to be displayed.
- Press ENTER.

#### 19.1.7 Totalizer storing

The totalizer values can be stored now.

- Select the menu item `Special functions\Data logger\Configuration`.
- Press ENTER until the menu item `Store totalizers` is displayed.
- Select `Yes`.
- Press ENTER.

## 19.2 FastFood mode

The FastFood mode allows to measure highly dynamic flows. A continuous adaptation to changing measuring conditions is only partially realized in the FastFood mode.

- The sound speed of the fluid is not updated. The last measured value of the sound speed before toggling to the FastFood mode is used.
- It is not possible to change the measuring channel. The measurement takes place on one channel only. As long as the FastFood mode is activated, no measurement is carried out on the other channels.
- The outputs of the channel activated in FastFood mode can still be used. They are updated synchronously with the FastFood measuring rate, independently from the storage rate.
- Outputs for further channels (multi-channel measurement) transmit an error value.
- The measured values are stored with the storage rate of the FastFood mode.
- The FastFood mode has to be enabled and activated.

FLUXUS \*722:

If the synchronized channel averaging is activated in the menu item `Special functions\Measurement\Measurement modes\Synch. chan. averag.`, this function will not be available.

### 19.2.1 Enabling/disabling the FastFood mode

```
Special functions\Measurement\Measurement modes\Enable FastFood
```

- Select the menu item `Measurement modes`.
- Press ENTER until the menu item `Enable FastFood` is displayed.
- Select `On` to enable the FastFood mode. Select `Off` to disable it.
- Press ENTER.

If `On` is selected, the menu item `Measuring rate FastF` is displayed. The FastFood measuring rate indicates in which interval measured values are transmitted to the process outputs.

- Select `Default` if no customized inputs are to be made (default: 50 ms).
- Select `Customized` if a value for the FastFood measuring rate is to be entered.
- Enter a value within the range 20...200 ms.
- Press ENTER.

### 19.2.2 Storage rate of the FastFood mode


The storage rate for the FastFood mode is entered during the configuration of the data logger in the menu item `Storage rate FastF`.

```
Special functions\Data logger\Configuration\Storage rate FastF
```

- Select the menu item `Configuration`.
- Activate the channels whose measured values have to be stored.
- Press ENTER until the menu item `Storage rate FastF` is displayed.
- Select `Automatic` if the storage rate has to correspond to the value of the FastFood measuring rate.
- Press ENTER.
- Select `Customized` if the value for the storage rate is to be defined.
- Press ENTER.
- Enter a value.
- Press ENTER.

### 19.2.3 Activation/deactivation of the FastFood mode

If the FastFood mode is enabled and a measurement is started, the normal measuring mode will still be running.

- Press  to activate the FastFood mode for the measuring channel currently displayed. The symbol for the FastFood mode  appears in the upper line.
- Press  to deactivate the FastFood mode.

The FastFood mode can be activated/deactivated via remote functions.

### 19.3 Calculation channels

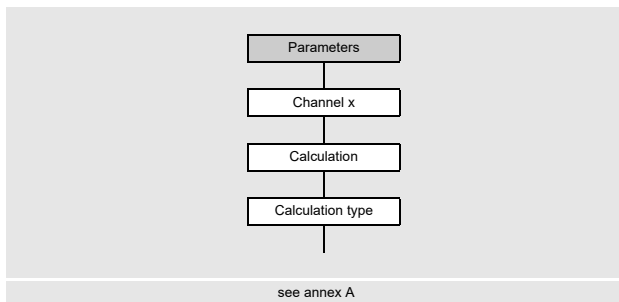
**Notice!**

Calculation channels are only available if the transmitter has more than one measuring channel.

In addition to the ultrasonic measuring channels, the transmitter has 2 virtual calculation channels Y and Z which calculate the measured values of all measuring channels.

The result of the defined calculation function is the measured value of the selected calculation channel. This measured value is equivalent to the measured values of a measuring channel. All operations which are possible with the measured values of a measuring channel (totalizing, storing, outputs, etc.) can also be done with the measured values of a calculation channel.

#### 19.3.1 Characteristics of the calculation channels



The measuring channels to be used for calculation and the calculation function have to be entered in the program branch `Parameters`.

It is possible to define 2 cut-off flows for each calculation channel. The cut-off flow is not based on the flow velocity as is the case with the measuring channels. Instead, it is defined in the unit of measurement of the physical quantity selected for the calculation channel. During the measurement, the calculation values are compared with the cut-off values and set to zero, if necessary.

#### 19.3.2 Parameterization of a calculation channel

`Parameters\Channel Y`

- Select a calculation channel (here: `Channel Y`) in the program branch `Parameters`.
- Press ENTER.

The current calculation function is displayed.

- Press ENTER.

##### 19.3.2.1 Selection of the calculation type

Tab. 19.2: Calculation types

Average (all chan. OK)	Average (1 chan. OK)	Special
mean with "AND" All measuring channels have to deliver a valid measuring value.  calculation function: $Y = (A + B) / 2$	mean with "OR" At least one measuring channel has to deliver a valid measuring value.  calculation function: $Y = (A + B) / n$	Each channel selected for calculation can be assigned with a signed value.

FLUXUS \*722:

If the synchronized channel averaging is activated in the menu item `Special functions\Measurement\Measurement modes\Synch. chan. averag.`, the average can only be selected as calculation type (AND or OR operation).

`Parameters\Channel Y\Calculation type`

- Select a calculation type.
- Press ENTER.
- Assign a measuring channel to each source channel.
- Press ENTER after each selection.



**Example**

calculation type:	Special
source channel 1:	Meas. Channel A
sign source channel 1:	A
source channel 2:	Meas. Channel B
sign source channel 2:	B
average:	1/2 (AND)
linear correction:	Yes
factor:	1.5 Factor
offset:	2.0 m/s
calculation function:	$1.5 * ( A  +  B ) / 2 + 2 \text{ m/s}$

**19.3.2.2 Input of limits**

It is possible to define limits for the physical quantity for each calculation channel. They are entered in the unit of measurement of the physical quantity selected for the calculation channel.

```
Parameters\Channel Y\Calculation type\+Upper limit
```

- Select `No limit` if the calculation channel has to output all positive values without upper limit.
- Press ENTER.
- Select `Set to limit` if the calculation channel has to output the limit when exceeding the upper limit.
- Press ENTER.
- Select `Set to error` if the calculation channel has to output an error (`UNDEF`) when exceeding the upper limit.
- Press ENTER.

```
Parameters\Channel Y\Calculation type\ -Upper limit
```

- Select `No limit` if the calculation channel has to output all negative values without upper limit
- Press ENTER.
- Select `Set to limit` if the calculation channel has to output the limit when falling below the upper limit.
- Press ENTER.
- Select `Set to error` if the calculation channel has to output an error (`UNDEF`) when falling below the upper limit.
- Press ENTER.

It is possible to define 2 cut-off flows for each calculation channel. They are entered in the unit of measurement of the physical quantity selected for the calculation channel.

```
Parameters\Channel Y\Calculation type\+Cut-off flow
```

- Enter a value for the positive cut-off flow.
- Press ENTER.

All positive calculated values below the limit are set to zero.

```
Parameters\Channel Y\Calculation type\ -Cut-off flow
```

- Enter a value for the negative cut-off flow as absolute value.
- Press ENTER.

All negative calculated values (as absolute value) below the limit are set to zero.

### 19.3.3 Output options for a calculation channel

- Select the program branch `Options`.
- Press ENTER.

`Options\Channel`

- Select a calculation channel for which the physical quantity is to be entered.
- Press ENTER.
- Select `Measurement`.
- Press ENTER.

`Options\Measurement\Physical quantity`

- Select a physical quantity which is to be transmitted via the calculation channel.
  - Press ENTER.
- For the selected physical quantity (except sound speed), a scroll list with the available units of measurement is displayed. The unit of measurement which was selected previously is displayed first.
- Select the unit of measurement of the physical quantity.
  - Press ENTER.

#### Notice!

If the thermal energy rate has to be output as physical quantity via the calculation channel, it has to be measured on all measuring channels.

`Options\Measurement\Damping`

- Enter the damping factor.
- If the damping factor for the measuring channels A or B has already been entered in the program branch `Options`, enter the value zero.
- Press ENTER.

### 19.3.4 Measurement with calculation channels

- Select the program branch `Measurement`.
- Press ENTER.

`Measurement>Select channels`

- Activate the necessary channels. Calculation channels are activated or deactivated the same way as measuring channels.
- Press ENTER.

#### Notice!

If a measuring channel that is needed for an activated calculation channel is deactivated, no value is output for the calculation channel.

### 19.3.5 Extended diagnostics

Extended diagnostics is available for the calculation channels in the ExperUser, SuperUser and SuperUser ext. mode. It serves to detect errors on individual measuring channels. The values of the extended diagnostics can either be transmitted via the outputs of the transmitter or defined as source of the event triggers.

#### Selection of the calculation channel

```
Options\Channel Y
```

- Select the program branch `Options`.
- Press ENTER.
- Select the calculation channel (here: `Channel Y`).
- Press ENTER.

#### Assignment of an output

- Select `Outputs`.
- Press ENTER.

```
Options\Channel Y\Outputs\Current I1(--)
```

- Select the output to be assigned to the calculation channel (here: `Current I1(--)`).
- Press ENTER.

The scroll list contains all available outputs of the transmitter.

If the output has already been assigned to a channel, it is displayed as follows: `Current I1 (Y)`.

```
Options\Channel Y\Outputs\Current I1\I1 Enable
```

- Select `Yes` to change the settings for an already assigned output or to assign a new output.
- Select `No` to cancel the assignment and to return to the previous menu item.
- Press ENTER.

#### Assignment of a source item

One source item has to be assigned to each selected output.

```
Options\Channel Y\Outputs\...\Source item
```

- Select `Extended diagnostics as source item`.
- Press ENTER.
- Select a list item for the quantity to be output.
- Press ENTER.

Tab. 19.3: Source item Extended diagnostics

source item	list item	output
Extended diagnostics	Valid channels	percentage of physical channels, with valid measuring state
	$\sigma$ (Sound speed)	standard deviation of the sound speed
	$\sigma$ (Flow velocity)	standard deviation of the flow velocity
	$\sigma$ (Amplification)	standard deviation of the signal amplification
	$\sigma$ (Amplitude)	standard deviation of the signal amplitude
	$\sigma$ (Quality)	standard deviation of the signal quality
	$\sigma$ (SNR)	standard deviation SNR
	$\sigma$ (SCNR)	standard deviation SCNR
	$\sigma$ (VariAmp)	standard deviation of the amplitude fluctuation
$\sigma$ (VariTime)	standard deviation of transit time fluctuation	

The list item `Valid channels` will not be displayed if a binary output was selected as output.  
 The status of a standard deviation is OK if a measured value for calculation is available on at least 2 measuring channels.

**Definition of an event trigger**

Options\Channel Y

- Select a calculation channel in the program branch `Options`, for which an event trigger is to be enabled (here: `Channel Y`).
- Press ENTER.
- Select the menu item `Event trigger`.
- Press ENTER.

Options\Channel Y\Event trigger\Rx(-)

- Select the event trigger.
- If the event trigger has already been enabled, it is displayed as follows: `R1(+)`

Options\Channel Y\Event trigger\Rx Enable

- Select `Yes` to change the settings for an already assigned event trigger or to assign a new one.
- Select `No` to cancel the assignment and to return to the previous menu item.
- Press ENTER.

Options\Channel Y\Event trigger\Rx Enable\Source item

- Select the source item `Extended diagnostics`.
- Press ENTER.
- Select the list item for which a condition is to be defined.
- Press ENTER.

## 19.4 Diagnosis with the help of the snap function

### 19.4.1 Configuration

By means of the snap function it is possible to store measuring parameters which are useful for the evaluation of measuring results or for diagnostic purposes. In order to use of the snap function it has to be configured.

```
Special functions\Snap\Configuration
```

- Select the menu item `Configuration`.
- Press ENTER.

```
Special functions\Snap\Configuration\Snap
```

- Select `On` to activate the snap function.
- Press ENTER.

```
Special functions\Snap\Configuration\Snap ringbuffer
```

- Select `Yes` to activate the snap ringbuffer.

If the snap ringbuffer is activated, after taking the 51th, snap the oldest snaps are overwritten. If the ringbuffer is deactivated, up to 50 snaps can be stored.

- Press ENTER.

```
Special functions\Snap\Configuration\Auto snap
```

- Select `Yes` if the auto snap has to be activated.

If the auto snap is activated, snaps are automatically stored during a measurement failure.

- Press ENTER.

```
Special functions\Snap\Configuration\Snap on R1
```

- Select `Yes` if an event that releases a snap has been parameterized for the event trigger R1.
- Press ENTER.

### 19.4.2 Taking a snap

```
Measurement\Execute command\Take a snap
```

- Press and hold `C` during the measurement until the menu item `Execute command` is displayed.
- Select the list item `Take a snap`.
- Press ENTER.

A snap will be taken.

### 19.4.3 Information concerning snaps

Special functions\Snap\Snap info

- Select the menu item `Snap info`.
- Press ENTER.

The following information is displayed:

display	description
Stored snaps:	number of stored snaps
Snaps left:	number of snaps that can still be stored
Ringbuffer:	snap ringbuffer activated

### 19.4.4 Deletion of snaps

Special functions\Snap>Delete snaps

- Select the menu item `Delete snaps`.
- Press ENTER.
- Select `Yes` or `No`.
- Press ENTER.

## 19.5 Modification of the limit for the inner pipe diameter

It is possible to modify the lower limit of the inner pipe diameter for a given transducer type.

- Select the program branch `Special functions`.
- Press ENTER.

Special functions\Pipe diameter MIN

- Select `Pipe diameter MIN`.
- Press ENTER.

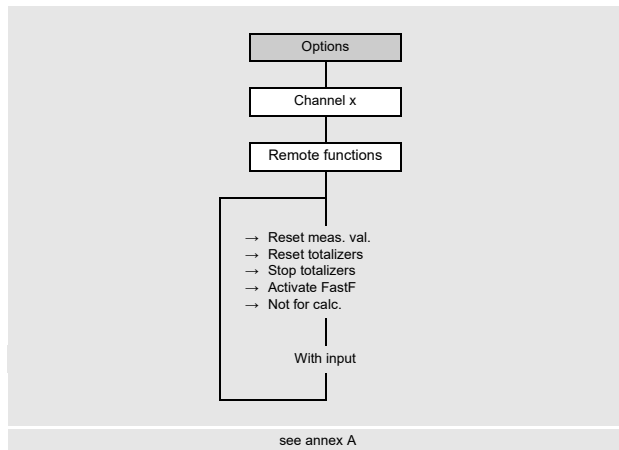
It is possible to define a min. pipe diameter for all relevant transducer frequencies.

- Select `Default` if no customized inputs are to be made and the default values are to be used.
- Press ENTER.
- Select `Customized` if a min. pipe diameter is to be defined.
- Press ENTER.
- Enter the pipe diameter in mm.
- Press ENTER.

#### Notice!

If a transducer is used below its recommended inner pipe diameter, a measurement might be impossible.

## 19.6 Remote functions



Remote functions can be triggered by event triggers, triggerable analog inputs or binary inputs.

In order to define an input for a remote function, it has to be enabled in the menu item `Special functions\Inputs`.

In order to define an event trigger for a remote function, it has to be enabled in the menu item `Options\Channel x\Event trigger`.

It is possible to trigger one or more of the following remote functions for different channels:

- reset of measured values
- reset of totalizers
- stop of totalizers
- activation of the FastFood mode
- not for calculation

### Triggerable inputs and event triggers

The remote function is triggered if the switching condition is met. The remote function is reset as soon as the switching condition is not longer met.

### Binary input

The remote function will be triggered if a voltage in the active range is applied at the binary input:

- FLUXUS S721\*\*-A20, FG721\*\*-NN0: 5...30 V
- FLUXUS \*72\*\*\*-F20: 5...26 V

The remote function will be reset if the voltage at the binary input is switched back to the passive range (< 5 V).

### 19.6.1 Configuration of the remote function

The remote function can be configured for each individual channel.


```
Options\Channel x\Remote functions
```

- Select the measuring channel in the program branch `Options` for which an remote function is to be activated.
- Press ENTER.
- Select the menu item `Remote functions`.
- Press ENTER.

In the scroll list of the functions it is displayed whether the function is assigned and if yes with which input or event trigger it is defined.

- Select a list item:
  - Reset meas. val. (-)
  - Reset totalizers (-)
  - Stop totalizers (-)
  - Activate FastF (-)
  - Not for calc. (-)

If this function has already been assigned to an input or event trigger, it is displayed as follows: `Reset meas. val. (R1)`.

- Press  to return to the previous menu.

### Reset of measured values

- Select the list item `Reset meas. val.`
- Press ENTER.

The measured value output simulates a reposing application for the duration of the signal. The actual measured flow velocity is ignored and the measured value is set to zero. All values of the physical quantity derived from the flow velocity and the values from the calculation channels also yield zero.

The transmitter continues the measurement if the condition of the remote function is no longer met.

- Select the input which is to be used to trigger the selected remote function.
- Press ENTER.
- Select `No linkage` in order to deactivate the remote function.
- Press ENTER.

### Reset of totalizers

- Select the list item `Reset totalizers.`
- Press ENTER.

The totalizers are set to zero. The totalizers are deactivated for the duration of the signal.

Totalizing starts at zero again, as soon as the condition for the remote function is no longer met.

When the totalizers are reset to zero with the remote function, the character `H` is displayed next to the measured value during the measurement.

- Select the input which is to be used to trigger the selected remote function.
- Press ENTER.
- Select `No linkage` in order to deactivate the remote function.
- Press ENTER.

### Stop of totalizers

- Select the list item `Stop totalizers.`
- Press ENTER.

The totalizers are stopped for the duration of the signal.

Totalizing will be continued with the last registered totalizer value if the condition of the remote function is no longer met.

- Select the input which is to be used to trigger the selected remote function.
- Press ENTER.
- Select `No linkage` in order to deactivate the remote function.
- Press ENTER.

### Activation of the FastFood mode

- Select the list item `Activate FastF.`
- Press ENTER.

The FastFood mode is activated for the duration of the signal. It is deactivated as soon as the condition for the remote function is no longer met.

This list item is only available for measuring channels and only appears if the FastFood mode was activated in menu item `Special functions\Measurement\Measurement modes\FastFood.`

- Select the input which is to be used to trigger the selected remote function.
- Press ENTER.
- Select `No linkage` in order to deactivate the remote function.
- Press ENTER.



**Not for calculation**

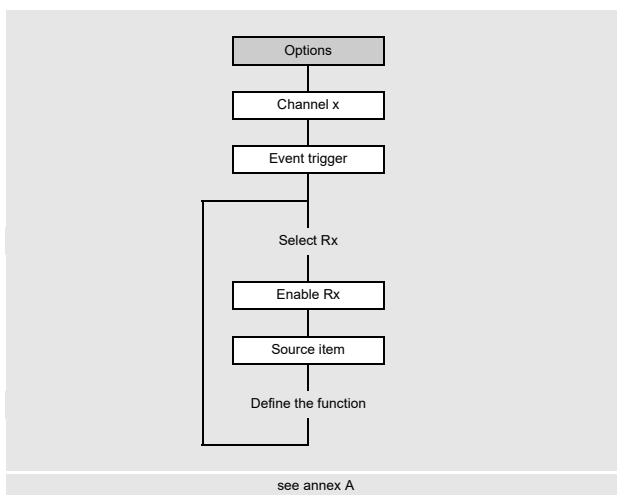
This function enables the user to define an event-based channel selection for calculation channels.

- Select the list item `Not for calc.`
- Press ENTER.

If the condition for the remote function is met, this measuring channel will not be calculated in the calculation channel. The measurement on the measuring channel continues running. The source of this remote function can be an event trigger or a process input.

The measuring channel is available again for the calculation channel, if the condition for the remote function is no longer met.

- Select the input which is to be used to trigger the selected remote function.
- Press ENTER.
- Select `No linkage` in order to deactivate the remote function.
- Press ENTER.

**19.7 Event triggers**

It is possible to configure max. 4 independent event triggers per channel: R1, R2, R3 and R4.

The event triggers can be used, e.g., to:

- output information about the running measurement
- trigger special remote functions
- switch on/off pumps and motors
- Select the program branch `Options`.
- Press ENTER.

```
Options\Channel x\Event trigger\Rx(-)
```

- Select the event trigger.

If an event trigger has already been installed, it is displayed as follows: `Rx (+)`.

```
Options\Channel x\Event trigger\Rx Enable
```

- Select `Yes` to change the settings for an already assigned event trigger or to assign a new one.
- Select `No` to cancel the assignment and to return to the previous menu item.
- Press ENTER.

```
Options\Channel x\Event trigger\Rx Enable\Source item
```

- Select the source item (physical quantity) for which a condition has to be defined.

Tab. 19.4: Source items

source item	list item	output
Flow quantities	Flow velocity	flow velocity
	Volumetric flow rate	volumetric flow rate
	Mass flow rate	mass flow rate
	Thermal energy rate	thermal energy rate
Totalizers	Volume (+)	totalizer for the volumetric flow rate in positive flow direction
	Volume (-)	totalizer for the volumetric flow rate in negative flow direction
	Volume ( $\Delta$ )	difference of the totalizers for the positive and negative flow direction
	Mass (+)	totalizer for the mass flow rate in positive flow direction
	Mass (-)	totalizer for the mass flow rate in negative flow direction
	Mass ( $\Delta$ )	difference of the totalizers for the positive and negative flow direction
	Thermal energy (+)	thermal energy totalizer for positive measured values of the thermal energy rate
	Thermal energy (-)	thermal energy totalizer for negative measured values of the thermal energy rate
Thermal energy ( $\Delta$ )	difference of the thermal energy totalizer	
Fluid properties	Fluid temp.	fluid temperature
	Supply temperature	supply temperature (thermal energy rate measurement)
	Return temperature	return temperature (thermal energy rate measurement)
	Temperature ( $\Delta$ )	difference between supply and return temperature (thermal energy rate measurement)
	Fluid pressure	fluid pressure
	Supply pressure	supply pressure (thermal energy rate measurement)
	Return pressure	return pressure (thermal energy rate measurement)
	Pressure ( $\Delta$ )	difference between supply and return pressure (thermal energy rate measurement)
	Fluid density	fluid density
	Kin. viscosity	kinematic viscosity
	Dyn. viscosity	dynamic viscosity
Diagnostic values	Amplitude	signal amplitude
	Quality	signal quality
	SNR	signal-to-noise ratio
	SCNR	signal-to-correlated noise ratio
	VariAmp	amplitude variation
	VariTime	transit time variation
	Amplification	amplification required to receive a useful signal
	Pig detection	signals whether a pig is detected This display will only be indicated if <code>Pig detection</code> is activated.

Tab. 19.4: Source items

source item	list item	output
Miscellaneous	Custom. Input 1	measured values of input quantities (e.g., temperature, density) which are not used for calculation  In the menu item <code>Options\Assign inputs</code> it is possible to assign configured inputs to customized inputs.
	Custom. Input 2	
	Custom. Input 3	
	Custom. Input 4	
Sound speed	Sound speed	measured sound speed in the fluid
	Sound speed ( $\Delta$ )	difference of the measured sound speed and the sound speed calculated from the fluid data

Afterwards the properties of the event trigger are defined.

Tab. 19.5: Properties of the event trigger

property	setting	description
Function (switching condition)	MAX ( $x > \text{limit}$ )	The event trigger switches when the measured value exceeds the upper limit.
	MIN ( $x < \text{limit}$ )	The event trigger switches when the measured value falls below the lower limit.
	ERR ( $x = \text{fail}$ )	The event trigger switches when a measurement is not possible.
	Within range	The event trigger switches when the measured value is within the defined range.
	Out of range	The event trigger switches when the measured value is outside the defined range.
Type (holding behavior)	Non-hold	When the switching condition is no longer met, the event trigger returns to the idle state after approx. 1 s.
	Hold	The event trigger remains activated even when the switching condition is no longer met.
	Hold for a while	The event trigger remains activated during a defined time even when the switching condition is no longer met.

### Definition of the switching condition

```
Options\Event trigger\Rx Enable\Source item\...\Function
```

- Select the switching condition.
- Press ENTER.

### Definition of the holding behavior

```
Options\Event trigger\Rx Enable\Source item\...\Type
```

- Select the type of the holding behavior.
- Press ENTER.

### Definition of trigger limits

```
Options\Event trigger\Rx Enable\Source item\...\Trigger value
```

The limits are to be entered at which the event trigger has to switch.

- Enter the upper limit MAX ( $x > \text{limit}$ ).
- Press ENTER.
- Enter the lower limit MIN ( $x < \text{limit}$ ).
- Press ENTER.

```
Options\Event trigger\Rx Enable\Source item\...\Hysteresis
```

It is possible to define a hysteresis to avoid constant switching of the event trigger.

The event trigger is activated when the measured values exceed the upper limit. It is deactivated when the measured values fall below the lower limit.

- Enter the value for the hysteresis.
- If zero is entered, no hysteresis is used.
- Press ENTER.

#### Example

```
MAX ( $x > \text{limit}$ ): 30 m3/h
```

```
Hysteresis: 1 m3/h
```

The event trigger is activated for measured values  $> 30.5 \text{ m}^3/\text{h}$  and deactivated for measured values  $< 29.5 \text{ m}^3/\text{h}$ .

```
Options\Event trigger\Rx Enable\Source item\...\Range center
```

- Enter the center of the range in which the event trigger has to be switched.
- Press ENTER.

```
Options\Event trigger\Rx Enable\Source item\...\Range width
```

- Enter the width of the range in which the event trigger has to be switched.
- Press ENTER.

#### Example

```
Function: Out of range
```

```
Range center: 100 m3/h
```

```
Range width: 40 m3/h
```

The event trigger will switch if the measured value is below  $80 \text{ m}^3/\text{h}$  or above  $120 \text{ m}^3/\text{h}$ .

### Definition of the switching delay

```
Options\Event trigger\Rx Enable\Source item\...\Glitch interval
```

- Enter a time interval after which the event trigger has to switch in case the event occurred.
- Press ENTER.

```
Options\Event trigger\Rx Enable\Source item\...\Failure delay
```

- Enter a time interval after which the event trigger has to be deactivated in case of a measurement failure.
- Press ENTER.

### 19.7.1 Apparent switching delay

The measured values and totalizer values will be displayed rounded according to the set number of decimal places. The limits, however, will be compared to the non-rounded measured values. This might cause an apparent switching delay when the measured value changes marginally (less than the visualized decimal places). In this case, the switching accuracy of the event trigger is higher than the accuracy of the display.

### 19.7.2 Reset and initialization of the event triggers

After an initialization of the transmitter all event triggers are deactivated.

- Press 3 times C during measurement to set all event triggers to the idle state.

Event triggers whose switching condition is still met will be activated again after 1 s. This function is used to reset event triggers of the type HOLD if the switching condition is no longer met.

If a measurement is stopped, all event triggers will be deactivated and the corresponding process outputs will be de-energized, independently of the programmed idle state.

### 19.7.3 Event trigger during the measurement

An event trigger with the switching condition MAX ( $x > \text{limit}$ ), MIN ( $x < \text{limit}$ ), Within range or Out of range is updated max. once per second to avoid a constant switching of the event trigger (in case the measured values fluctuate around the value of the switching condition).

An event trigger with switching condition ERR ( $x = \text{fail}$ ) is activated during a measurement failure.

An event trigger of the type Non-hold is activated when the switching condition is met. It is deactivated when the switching condition is no longer met. But it remains activated for at least 1 s even when the switching condition is met for a shorter period of time.

An event trigger of the type Hold is activated when the switching condition is met. It remains activated even when the switching condition is no longer met.

An event trigger of the type Hold for a while is activated when the switching condition is met. The time after which the deactivation takes place is defined in the menu item Hold interval.

### 19.7.4 Status display of the event triggers

<b>Notice!</b>
There is no visual or acoustic indication of event trigger switching.











The state of the event triggers is displayed during the measurement.

- Press 9 to scroll through the second line from below until the event trigger status is displayed.



The status display of the event triggers is structured as follows.

R<sub>x</sub> =    with X being the number of the event trigger and  a pictogram according to Tab. 19.6.


Tab. 19.6: Pictograms for the status display of the event triggers

	no.		Function (switching condition)	Type (holding behavior)	current state
R	<input type="text"/>	=	<input type="text"/>	<input type="text"/>	<input type="text"/>
	1		 MAX ( $x > \text{limit}$ )	 Non-hold	 deactivated (false state)
	2		 MIN ( $x < \text{limit}$ )	 Hold	 activated (true state)
	3		 Within range	 Hold for a while	
	4		 Out of range		
			 ERR ( $x = \text{fail}$ )		

### Example

R1 =   



## 19.8 Event protocol

If an error occurs, an error message will be displayed in the first line indicating the symbol . The error message can be displayed via the menu item `Event log`.

`Special functions\System settings\Event log`

- Select the menu item `Event log`.
- Press ENTER.

A list is displayed containing all error messages since the last time the transmitter was switched on.

- Press  and  to select an error message.
- Press ENTER.

The display indicates the cause of the error.

### Notice!

After reading out the event protocol the error message symbol will be deleted on the display, even if the error has not been eliminated yet.

The event protocol will be deleted after a restart of the transmitter.

## 20 Settings

### 20.1 Dialogs and menus

Special functions\Dialogs/Menu

- Select the menu item `Dialogs/Menu` in the program branch `Special functions`.
- Press ENTER.

#### Pipe circumference

Special functions\Dialogs/Menu\Pipe circumference

- Select the menu item `Pipe circumference`.
- Select `Yes` if the pipe circumference is to be entered instead of the pipe diameter in the program branch `Parameters`.
- Press ENTER.

If `Yes` is selected for `Pipe circumference`, the outer pipe diameter will still be requested in the program branch `Parameters`.

- Press  to select the menu item `Pipe circumference`.
- Press ENTER.

The value displayed in the menu item `Pipe circumference` is calculated from the last displayed outer pipe diameter.

Example: 100 mm · π = 314.2 mm

- Enter the pipe circumference. The limits for the pipe circumference are calculated on the basis of the limits for the outer pipe diameter.
- Press ENTER.

During the next scroll through the program branch `Parameters`, the outer pipe diameter that corresponds to the entered pipe circumference will be displayed.

Example: 180 mm : π = 57.3 mm

#### Coating

If the pipe has a coating, the material parameters of the coating have to be entered in the program branch `Parameters`.

Special functions\Dialogs/Menu>Edit coating

- Press ENTER until the menu item `Edit coating` is displayed.
- Select `Yes` if the pipe has a coating.
- Press ENTER.

#### Lining 2

If the pipe has a second lining, the material parameters of the coating have to be entered in the program branch `Parameters`.

Special functions\Dialogs/Menu>Edit Lining 2

- Press ENTER until the menu item `Edit Lining 2` is displayed.
- Select `Yes` if the pipe has 2 linings.
- Press ENTER.

#### Measuring point number

Special functions\Dialogs/Menu\Measuring point no.

- Press ENTER until the menu item `Measuring point no.` is displayed.
- Select `Number` if the measuring point number should only consist of numeric characters. Select `Text` if the measuring point number should only consist of alphabetic characters.
- Press ENTER.

### Error delay

The error delay is the time after which an error value will be sent to an output if no valid measured values are available.

```
Special functions\Dialogs/Menus/Error delay
```

- Press ENTER until the menu item `Error delay` is displayed.
- Select `Edit` to enter an error delay. Select `Damping` if the damping factor is to be used as the error delay.
- Press ENTER.

### Temperature correction

```
Special functions\Dialogs/Menus/Tx temperature offset
```

- Press ENTER until the menu item `Tx temperature offset` is displayed.
- Select `Yes` to enable the input of a temperature correction for each temperature input.
- Press ENTER.

### Transducer distance

```
Special functions\Dialogs/Menus/Transducer distance
```

- Press ENTER until the menu item `Transducer distance` is displayed.
- Select `Customized` if the measuring point is always the same. Select `Automatic` if the measuring point often changes.
- Press ENTER.

In the program branch `Measurement`, the recommended transducer distance will be displayed in parenthesis, below the entered transducer distance.

### Sound speed of the reference fluid

```
Special functions\Dialogs/Menus/Compare c fluid
```

- Press ENTER until the menu item `Compare c fluid` is displayed.

Select `Yes` if the difference  $\Delta c = c_{\text{mea}} - c_{\text{stored}}$  between the two sound speeds has to be displayed.  $c_{\text{ref}}$  is the calculated sound speed of the reference fluid at same process conditions (temperature, pressure).

- Press ENTER.

`Compare c fluid` can also be activated or deactivated during the measurement and has an immediate effect on the display of the measured values.

- Press  during the measurement to scroll to the display of  $\Delta c$ .

### Display of the last value

```
Special functions\Dialogs/Menus/Display last value
```

- Press ENTER until the menu item `Display last value` is displayed.
- Select `Yes` to display the last valid value.
- Press ENTER.

If `Yes` is selected and no valid measured value can be displayed during the measurement, the channel will display the last valid value. Behind this value an interrogation point will be displayed.



### Toggle time

The toggle time indicates the time interval after which the transmitter toggles between the different channels during the measurement. The default value is 3 s.

```
Special functions\Dialogs/Menus\Toggle time
```

- Press ENTER until the menu item `Toggle time` is displayed.
- Enter a different toggle time value if the default value is not to be used.
- Press ENTER.

This value remains stored until a new toggle time is entered.

### Primary display value

```
Special functions\Dialogs/Menus\Primary display value
```

- Press ENTER until the menu item `Primary display value` is displayed.
- Select `Flow quantity` to display the selected physical quantity value as primary value during the measurement. Select `Totalizer` to display the totalizer value as primary value during the measurement.
- Press ENTER.

### Switching off the display backlight

```
Special functions\Dialogs/Menus\Light autom. off
```

- Press ENTER until the menu item `Light autom. off` is displayed.
- Select `Yes` to activate the automatic switch-off.
- Press ENTER.

If the automatic switch-off of the display backlight is activated, the backlight is switched off after about 30 s. When pressing a key or connecting a USB cable, the backlight is switched on again.

## 20.2 Measuring modes

```
Special functions\Measurement\Measurement modes
```

- Select the menu item `Measurement` in the program branch `Special functions`.
- Press ENTER.
- Select the menu item `Measurement modes`.
- Press ENTER.

### Synchronized channel averaging (FLUXUS \*722)

```
Special functions\Measurement\Measurement modes\Synch. chan. averag.
```

- Select `On` to activate the synchronized channel averaging. Select `Off` to deactivate it.
- Press ENTER.

### FastFood mode

```
Special functions\Measurement\Measurement modes\Enable FastFood
```

- Select `On` to enable the FastFood mode. Select `Off` to disable it.
- Press ENTER.

If the synchronized channel averaging is activated, this display will not be indicated.

## 20.3 Measurement settings

Special functions\Measurement\Measurement settings

- Select the menu item `Measurement` in the program branch `Special functions`.
- Press ENTER.
- Select the menu item `Measurement settings`.
- Press ENTER.

### Multi-point calibration

A multi-point calibration allows a very precise output of measuring results. It is based on calibration curves of series of measured values

Special functions\Measurement\Measurement settings\Multi-point calibration

- Select the menu item `Multi-point calibration`.
- Select `On` to activate the multi-point calibration. Select `Off` to deactivate it (default: `Off`).
- Press ENTER.

If `On` is selected, a series of measured values has to be entered in the program branch `Options`.

### Swift damping

If `Swift damping` is activated, each displayed measured value is a floating average of the last `x` seconds, with `x` being the damping factor. The display thus takes `x` seconds to fully respond to flow rate changes.

If `Swift damping` is deactivated, the damping is calculated as first order low-pass filter, i.e. changes of measured values become effective in form of an exponential time course in the measuring result.

Special functions\Measurement\Measurement settings\Swift damping

- Select the menu item `Swift damping`.
- Select `Off` to deactivate the swift damping. Select `On` to activate it (default: `On`).
- Press ENTER.

### Dynamic damping

If dynamic damping is activated, volatile changes in the measured values of the selected physical quantity are transmitted through the transmitter without any time lag.

#### Important!

The dynamic damping will only have impact on the selected physical quantity. All other physical quantities are not dynamically damped.

Special functions\Measurement\Measurement settings\Dynamic damping

- Select the menu item `Dynamic damping`.
- Select `On` to activate the dynamic damping and `Off` to deactivate it (default: `Off`).
- Press ENTER.

If `On` is selected, the dynamic damping has to be parameterized in the menu item `Options\Channel A\Measurement\Dynamic damping`.

## 20.4 Units of measurement

It is possible to set the global units of measurement for length, temperature, pressure, sound speed, density and kinematic viscosity.

Special functions\Units of measurement

- Select the menu item `Units of measurement`.
- Press ENTER.
- Select a unit of measurement for all quantities.
- Press ENTER.

Special functions\Units of measurement\Barrel type

In this menu item it is possible to define which barrel type is to be displayed as unit of measurement for the volumetric flow rate.

- Select a barrel type.
- Press ENTER.

## 20.5 Material and fluid scroll list

At delivery, all stored materials and fluids are displayed in the corresponding lists in the menu item `Parameters\Pipe material` or `Parameters\Fluid`.

For the sake of clarity, materials and fluids can be removed from the scroll list. Removed materials and fluids can be added at any time.

### Adding or removing materials/fluids

- Select the menu item `Special functions\Libraries\Use material list`.
- Press ENTER.

Special functions\Libraries\Use material list

- Select `Yes` if a material is to be added or removed from the material scroll list.
- Press ENTER.
- Press `8` or `2` to scroll through the scroll list.
- Press `6` or `4` to add (+) or remove (-) a material.
- Press ENTER.

Similarly, the fluid scroll list can be adapted (`Special functions\Libraries\Use fluid list`).

### Adding all materials/fluids

- Select the menu item `Special functions\Libraries\Use material list`.
- Press ENTER.

Special functions\Libraries\Use material list

- Select `No` if all materials are to be displayed in the material scroll list.
- Press ENTER.

Similarly, the fluid scroll list can be adapted (`Special functions\Libraries\Use fluid list`).

## 20.6 Working with parameter records

### 20.6.1 Introduction

Parameter records are data sets that contain all information necessary to perform a certain measurement task:

- pipe parameters
- transducer parameters
- fluid parameters
- output options

Working with parameter records will make repeated measurement tasks easier and faster. The transmitter can store max. 20 parameter records.

#### Notice!

No parameter records are stored in the delivery state. Parameter records have to be entered manually.

The parameters have first to be entered in the program branches `Parameters`, `Options` and `Special functions`. Afterwards, they can be stored as parameter record.

```
Special functions\Param. record memo.
```

- Select the menu item `Param. record memo.`
- Press ENTER.
- Select `Save current record.`
- Press ENTER.

```
Special functions\Param. record name
```

- Enter the name the parameter record has to be stored with.
- Press ENTER.

### 20.6.2 Load of a parameter record

Stored parameter records can be loaded and used for measurement.

```
Special functions\Param. record memo.\Load param. record
```

- Select the menu item `Load param. record.`
- Press ENTER.
- Select the parameter record to be loaded.
- Press ENTER.

### 20.6.3 Deletion of parameter records

```
Special functions\Param. record memo.\Delete param. record
```

- Select the menu item `Delete param. record.`
- Press ENTER.
- Select the parameter record to be deleted.
- Press ENTER.


## 20.7 Contrast settings

Special functions\System settings\Display contrast

- Select the menu item `System settings` in the program branch `Special functions`.
- Press ENTER.
- Select the menu item `Display contrast`.
- Press ENTER.

The display contrast is adjusted with the following keys:

 increases the contrast

 reduces the contrast


- Press ENTER.

### Notice!

After an initialization of the transmitter, the display is reset to medium contrast.

## 20.8 HotCodes

A HotCode is a digit sequence that activates certain functions and settings.

- Press  for several seconds to return to the beginning of the program branch.
- Press C.
- Enter the HotCode via the keyboard. It is not displayed during the input.

function	HotCode
display setting to medium contrast	555000
language selection	9090xx
initialization	909000
activation/deactivation of the flow direction detection	007026
activation/deactivation of the pig detection	007028
display of totalizers in the lower line as well	007032

### Language selection

The language selection can either be carried out in the program branch `Special functions` or by entering a HotCode:

language	HotCode
English	909044
German	909049
French	909033
Spanish	909034
Dutch	909031
Russian	909007
Polish	909048
Turkish	909090
Italian	909039

After the last digit has been entered, the main menu is displayed in the selected language. The selected language remains activated when the transmitter is switched off and on again.

## 20.9 Key lock

An ongoing measurement can be protected from an inadvertent intervention by means of a key lock.

### Definition of a key lock code

- Select the menu item `System settings` in the program branch `Special functions`.
- Press ENTER.

`Special functions\System settings\Key lock`


- Select `Key lock`.
- Press ENTER.
- Enter a 6-digit key lock code.
- Press ENTER.

### Notice!

Do not forget the key lock code!

### Intervention in the measurement

If the key lock is activated, the message `Key lock activated` will be displayed for a few seconds when pressing a key. In order to interrupt a measurement, the key lock has to be deactivated.

- Press .
- Select `Show parameters`.
- Press ENTER.
- Deactivate the key lock.

### Deactivation of the key lock

- Select the menu item `System settings` in the program branch `Special functions`.
- Press ENTER.

`Special functions\System settings\Key lock`

- Select `Key lock`.
- Press ENTER.
- Enter a 6-digit key lock code.
- Press ENTER.

### Disabled functions with activated key lock

The following table gives an overview of the transmitter functions that are not available when the key lock is activated.

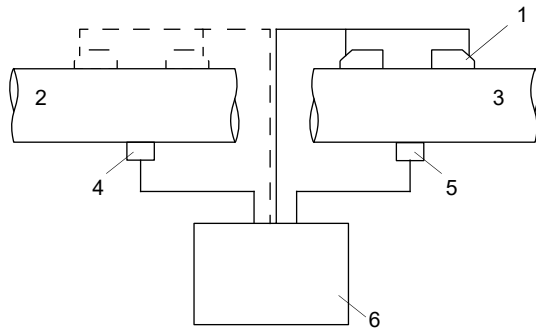
measurement not started	measurement started
<ul style="list-style-type: none"> <li>• parameter input</li> <li>• modification of settings (e.g., measuring modes)</li> <li>• deletion of the data logger</li> <li>• setting of time/date</li> <li>• start of measurement (start-up)</li> </ul>	<ul style="list-style-type: none"> <li>• modification of settings that are available in an ongoing measurement (e.g., language selection)</li> <li>• triggering snaps</li> <li>• toggling to FastFood mode</li> <li>• toggling to NoiseTrek mode</li> <li>• stop of the totalizers</li> <li>• reset of the totalizers</li> <li>• stop of the measurement</li> </ul>

## 21 Thermal energy rate measurement (option)

If the transmitter has the optional thermal energy measurement and 2 temperature inputs, the thermal energy rate can be measured. A temperature probe is fixed on the supply and the return line.

The transducers are fixed on the return line. If this is not possible, they can also be mounted on the supply line.

Fig. 21.1: Thermal energy rate measurement with flow measurement



- 1 – transducer
- 2 – supply line
- 3 – return line
- 4 – temperature probe on supply line (temperature input  $T_V$ )
- 5 – temperature probe on return line (temperature input  $T_R$ )
- 6 – transmitter

Tab. 21.1: Possible measurement arrangements

<b>heating application</b>	$T_V > T_R$	transducers on supply line
		transducers on return line
<b>cooling application</b>	$T_V < T_R$	transducers on supply line
		transducers on return line

A temperature correction value (offset) can be set for each temperature input.

The thermal energy is the totalizer of the thermal energy rate.

### 21.1 Calculation of the thermal energy rate

The thermal energy rate is calculated with the following formula:

$$\Phi = k_i \cdot \dot{V} \cdot (T_V - T_R)$$

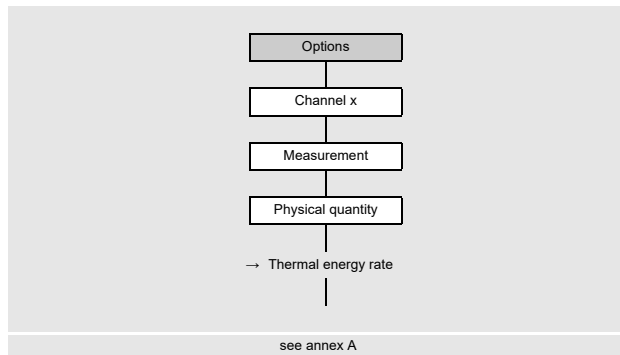
where

- $\Phi$  – thermal energy rate
- $k_i$  – thermal coefficient
- $\dot{V}$  – volumetric flow rate
- $T_V$  – supply temperature
- $T_R$  – return temperature

The thermal coefficient  $k_i$  is calculated from several thermal energy rate coefficients for the specific enthalpy and the density of the fluid. The thermal coefficients of some fluids are stored in the internal database of the transmitter.

If no thermal energy rate coefficients are available for the selected fluid, an error message will be displayed.

## 21.2 Definition of the physical quantity and the unit of measurement



Options\Channel x\Measurement

- Select the menu item `Measurement`.
- Press ENTER.
- Select the list item `Thermal energy rate`.
- Press ENTER.
- Select the unit of measurement to be used for the thermal energy rate.
- Press ENTER.

## 21.3 Application and transducer positioning

Options\Channel x\Measurement\Application

- Select `Heating` if the system is to be operated as heating application.
- Press ENTER.
- Select `Cooling` if the system is to be operated as cooling application.
- Press ENTER.

Options\Channel x\Measurement\Transducer location

- Select `Return line` if the measurement arrangement was configured for a thermal energy rate measurement on the return line.
- Press ENTER.
- Select `Supply line` if the measurement arrangement was configured for a thermal energy rate measurement on the supply line.
- Press ENTER.

Options\Channel x\Measurement\Thermal energy rate

- Select `Sign` if the sign of the thermal energy rate is not to be considered.
- Press ENTER.
- Select `Absolute value` if the absolute value of the thermal energy rate is to be displayed.
- Press ENTER.

Options\Channel x\Measurement\Phase transition

- Select `Yes` if the aggregate state of the fluid changes between the return and supply line. Select `No` if it does not change.
- Press ENTER.

This function is not available, if water, ammonia or a coolant has been selected as fluid in the program branch `Parameters`.

In the `SuperUser` mode it is possible to additionally enter a lower limit of the temperature difference.

Options\Channel x\Measurement\Limit  $\Delta T$

- Select the menu item `Options` in the program branch `Special settings`.
- Press ENTER until the menu item `Limit  $\Delta T$`  is displayed.
- Select `Customized` to define a lower limit for the thermal energy rate measurement.
- Select `Default` if no customized inputs are to be made and the default values are to be used.
- Select `Off` if no lower limit for the thermal energy rate measurement is to be defined.
- Press ENTER.



### 21.4 Assignment of the temperature inputs

The supply and return temperature are assigned to the measuring channels as `Supply temperature` and `Return temperature` respectively. The temperatures can be measured or entered as constant values.

The inputs have to be enabled in the menu item `Special functions\Inputs`.

`Options\Channel x\Assign inputs`

- Select the list item `Assign inputs`.
- Press ENTER.
- Select the list item `Supply temperature`.
- Press ENTER.
- Select the assignment to determine the supply temperature. Select `Fixed value` if the supply temperature is known and constant during the entire measuring time. The value has to be entered in the program branch `Parameters`.
- Press ENTER.
- Select the list item `Return temperature`.
- Press ENTER.
- Select the assignment to determine the return temperature. Select `Fixed value` if the return temperature is known and constant during the entire measuring time. The value has to be entered in the program branch `Parameters`.
- Press ENTER.

### 21.5 Two independent thermal energy rate measurements

If the transmitter has 2 measuring channels and 4 temperature inputs for each measuring channel, it is possible to conduct 2 independent thermal energy rate measurements at the same time.

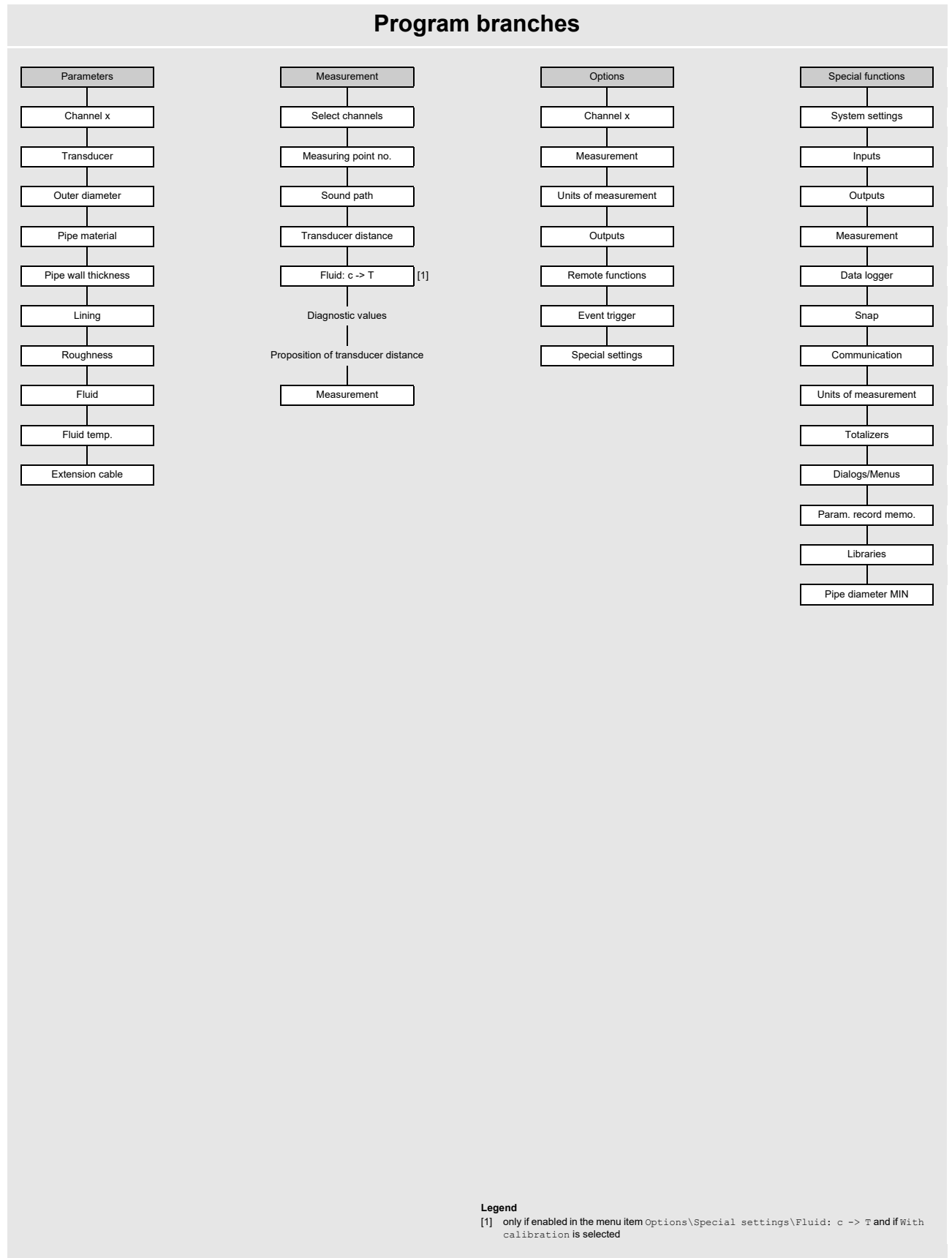
Tab. 21.2: Configuration of the temperature inputs in case of 2 independent thermal energy rate measurements

		temperature input
<b>measuring channel A</b>	supply temperature	T1 or constant value
	return temperature	T2 or constant value
	measurement of thermal energy	possible
<b>measuring channel B</b>	supply temperature	T3 or constant value
	return temperature	T4 or constant value
	measurement of thermal energy	possible

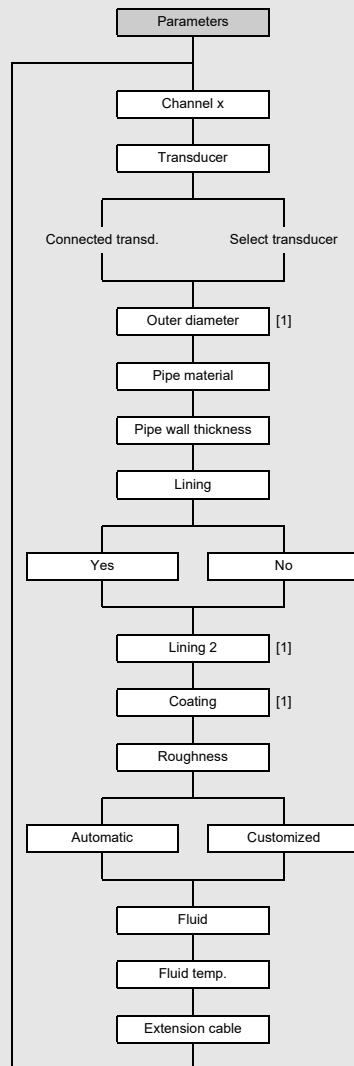


# Annex

## A Menu structure

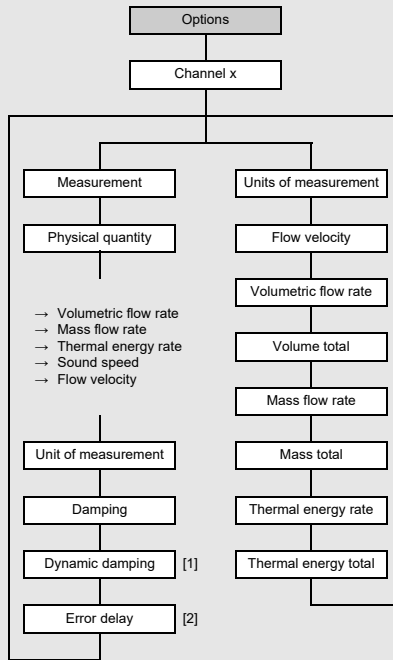


## Parameter input



**Legend**  
[1] only if enabled in the menu item Special functions\Dialogs\Menus

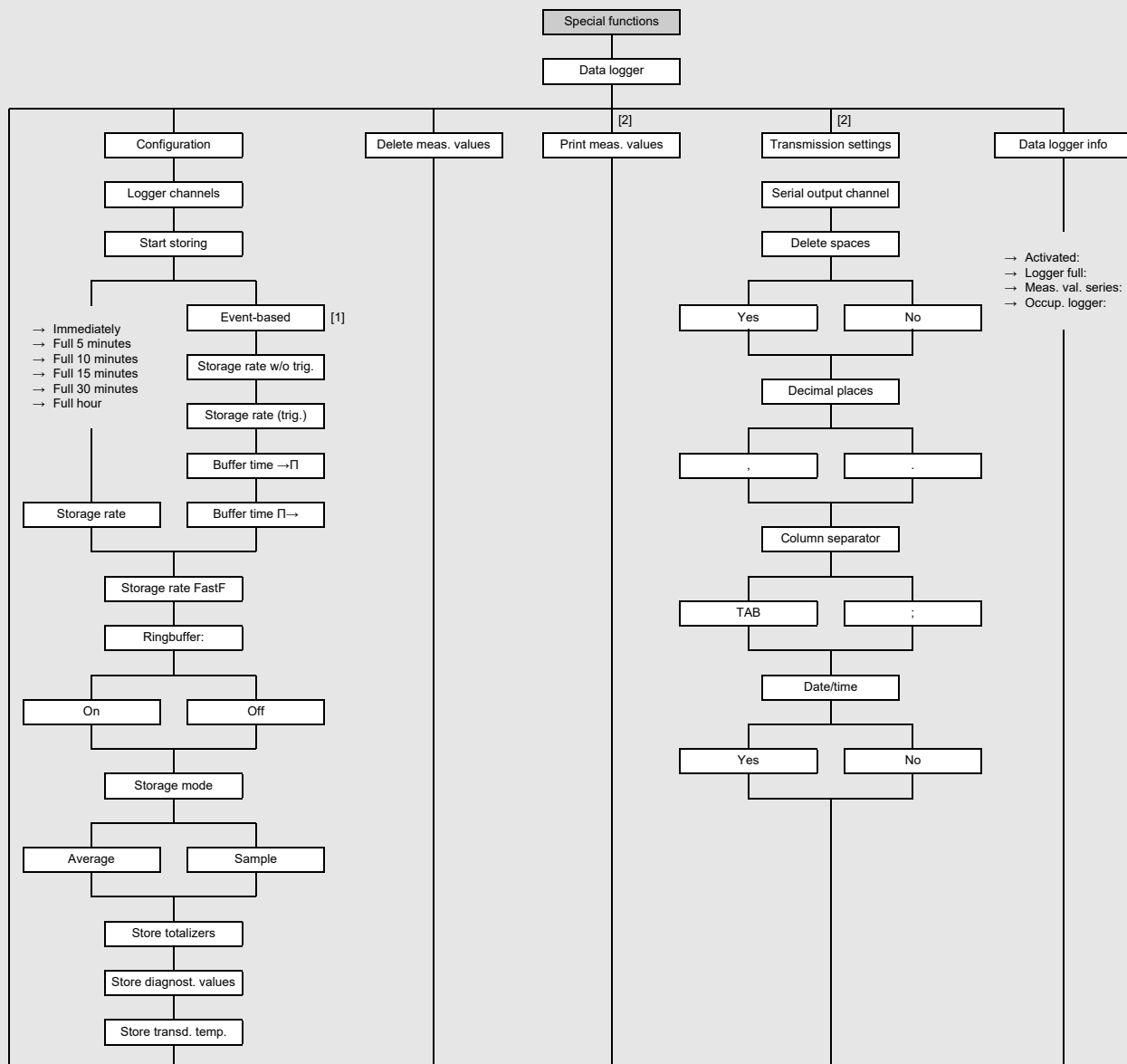
## Measurement settings



**Legend**

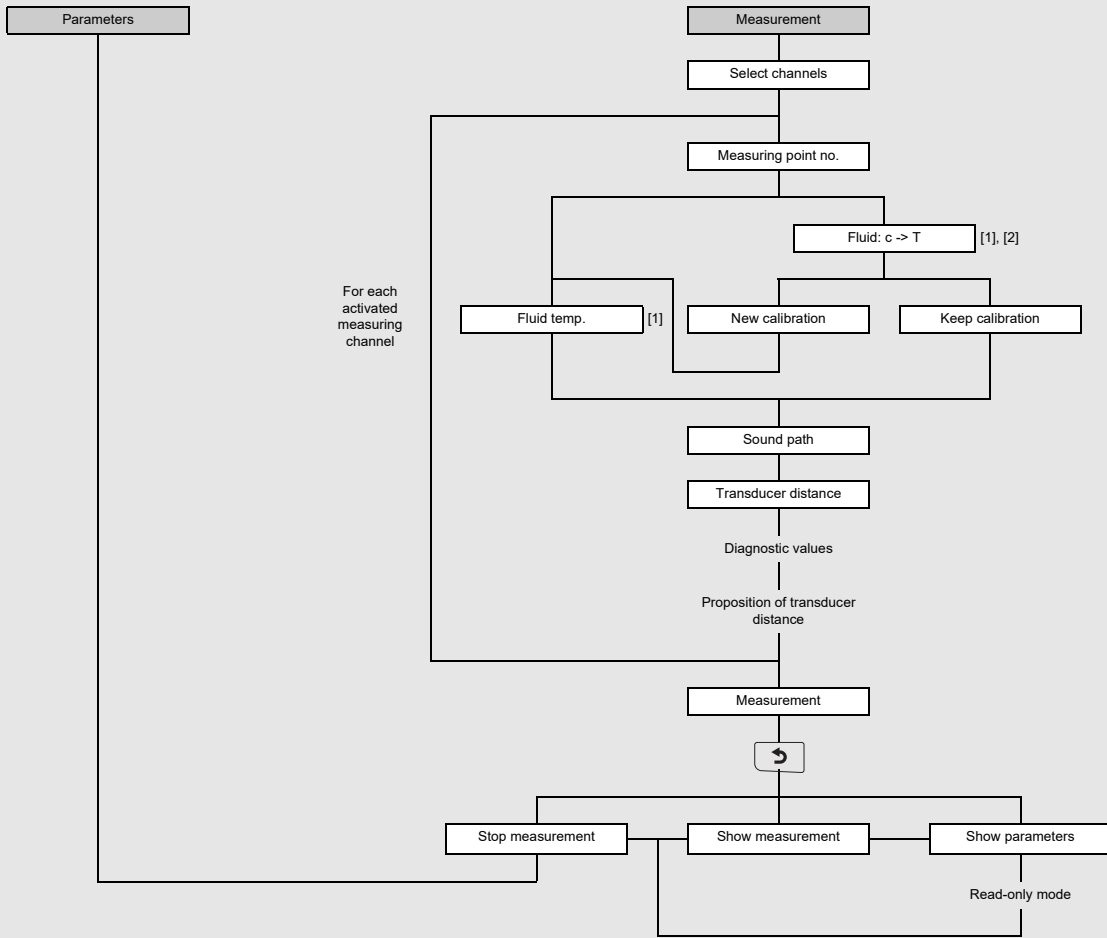
- [1] only if enabled in the menu item Measurement\Measurement settings\Dynamic damping
- [2] only if enabled in the menu item Special functions\Dialogs\Menus

## Data logger



**Legend**  
 [1] list of parameterized triggerable inputs and event triggers  
 [2] only if RS485 interface is available

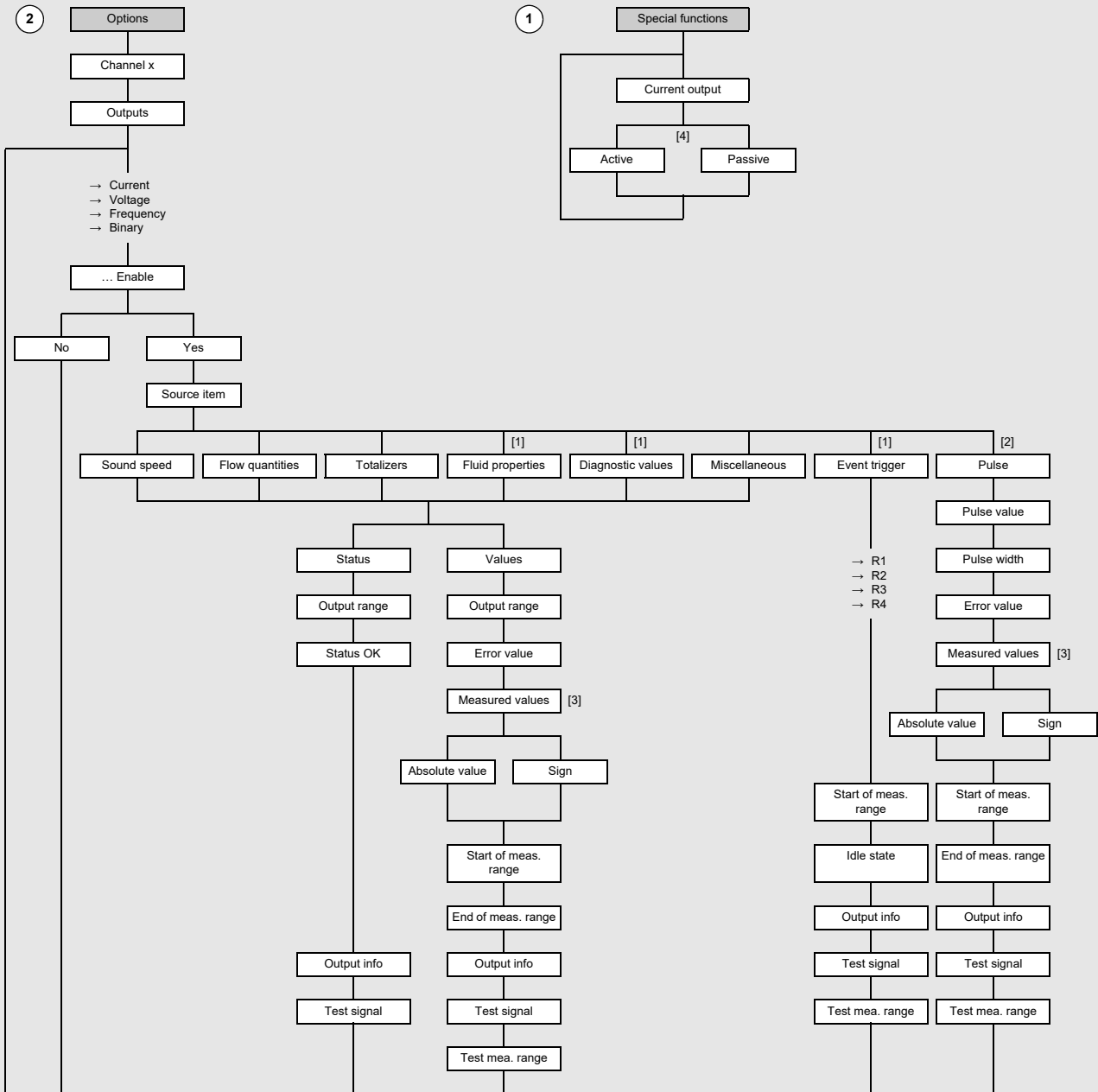
### Measurement start



**Legend**

- [1] only if enabled in the menu item Options\Special settings\Fluid: c -> T and if With calibration is selected
- [2] only if an offset has already been stored for the corresponding measuring channel of the transmitter

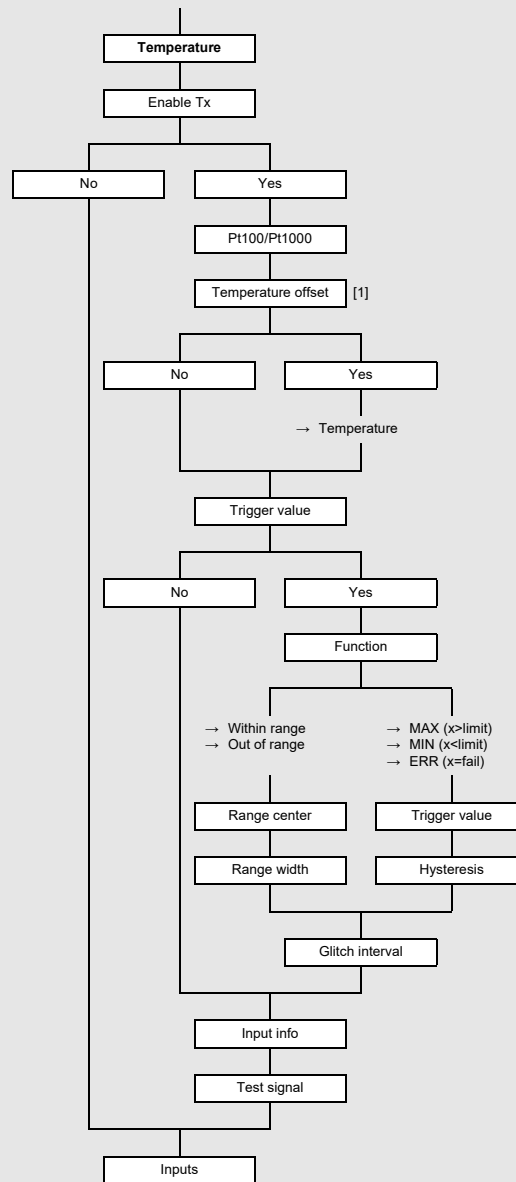
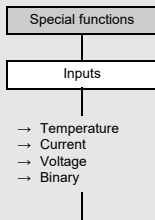
### Configuration of outputs



- Legend**
- [1] not available for calculation channels
  - [2] only available for binary outputs supporting pulse output
  - [3] requested only if the physical quantity can adopt a negative value
  - [4] only if switchable current outputs are available



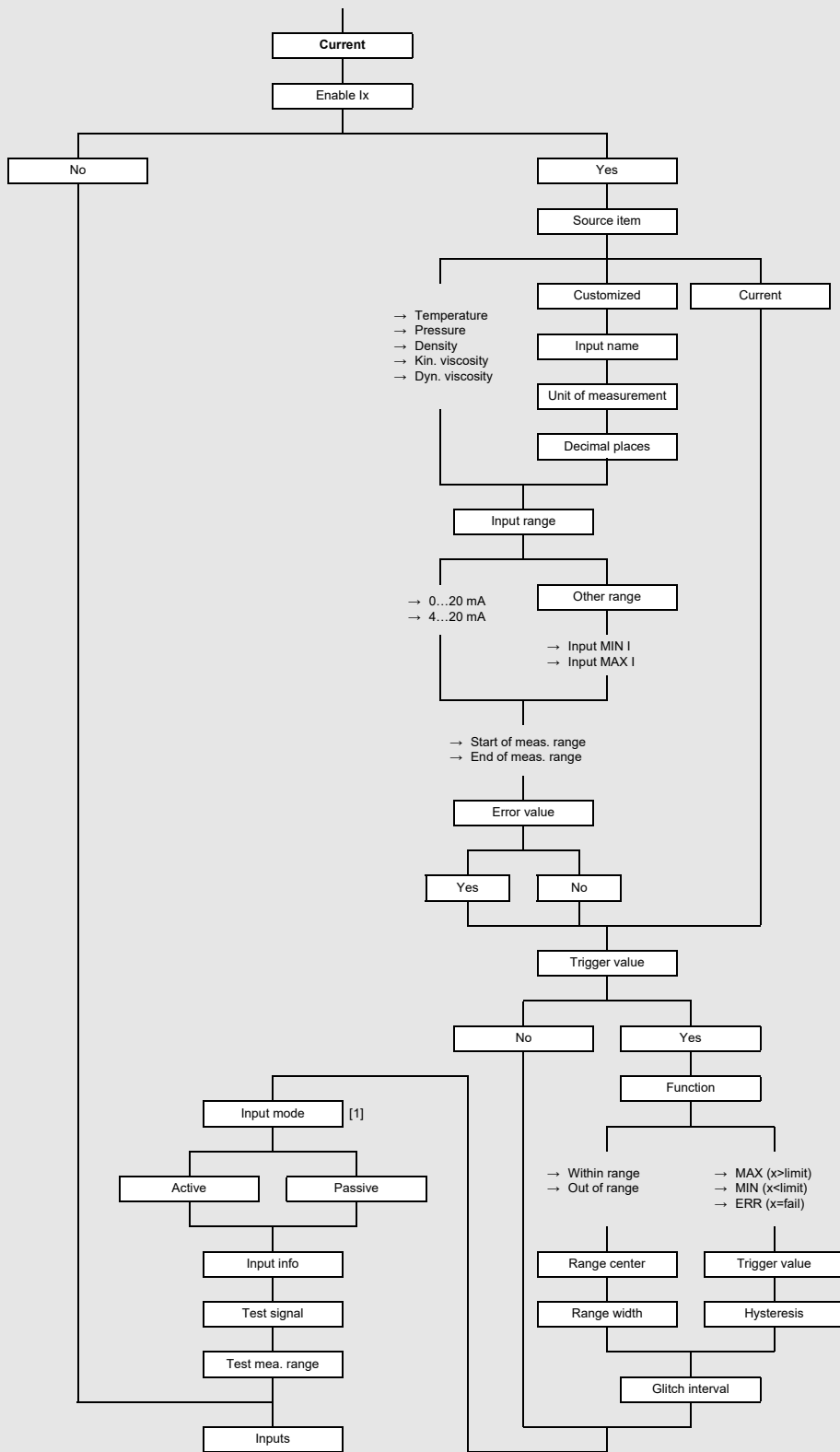
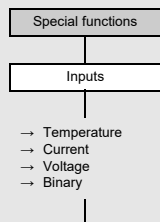
## Configuration of inputs



**Legend**

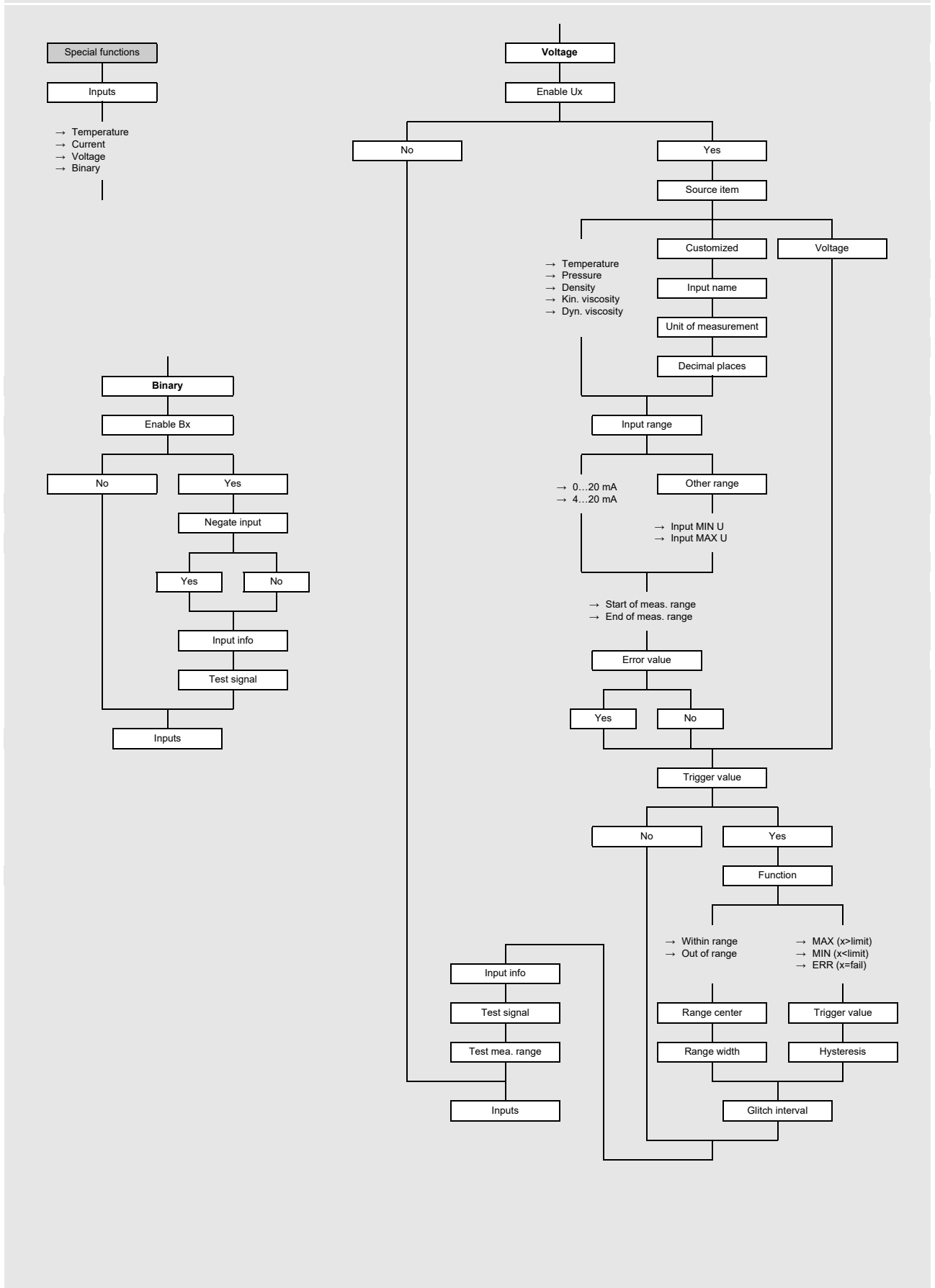
[1] only if enabled in the menu item Special functions\Dialogs\Menus

### Configuration of inputs

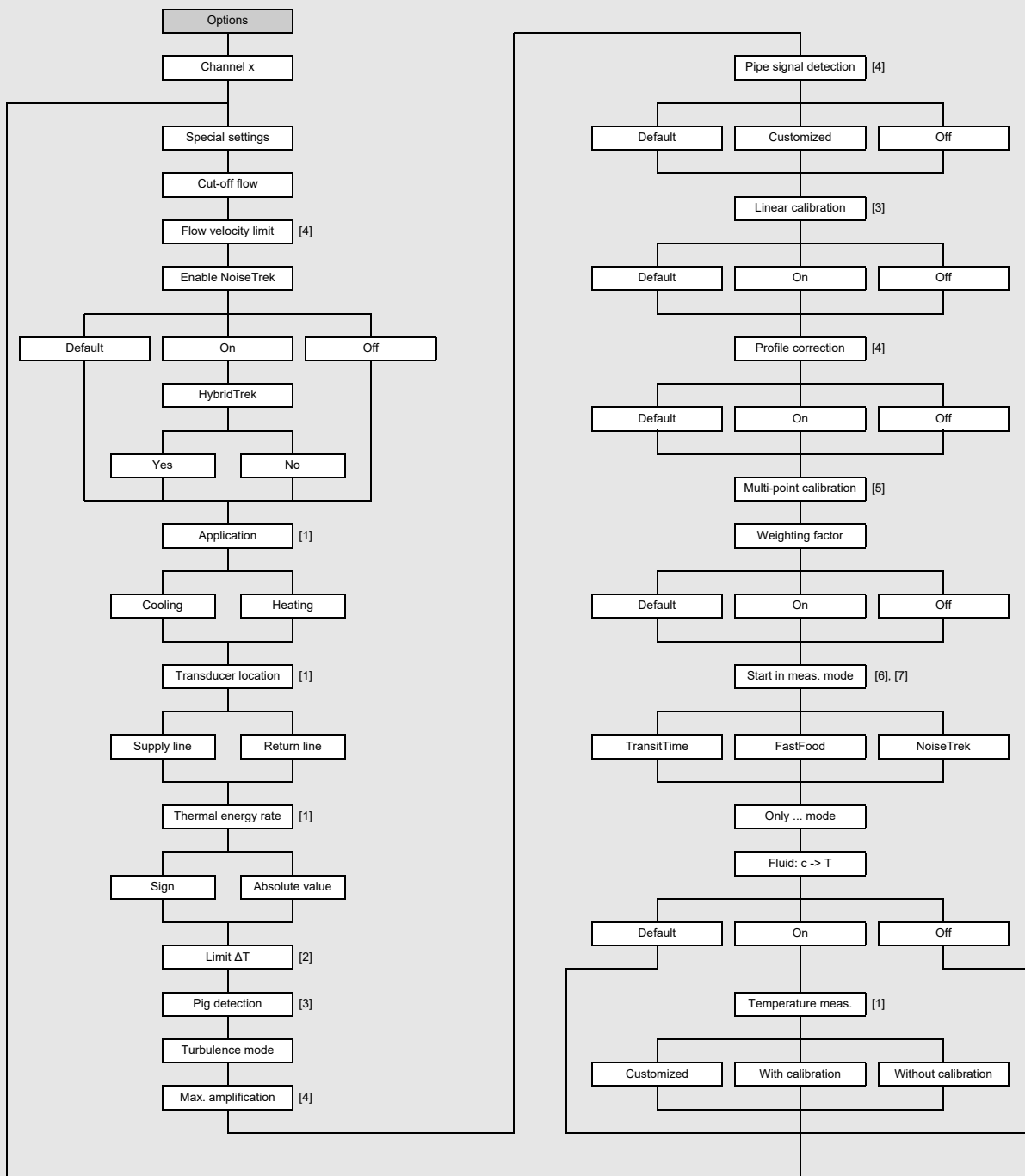


**Legend**  
[1] only if supported by the hardware

## Configuration of inputs



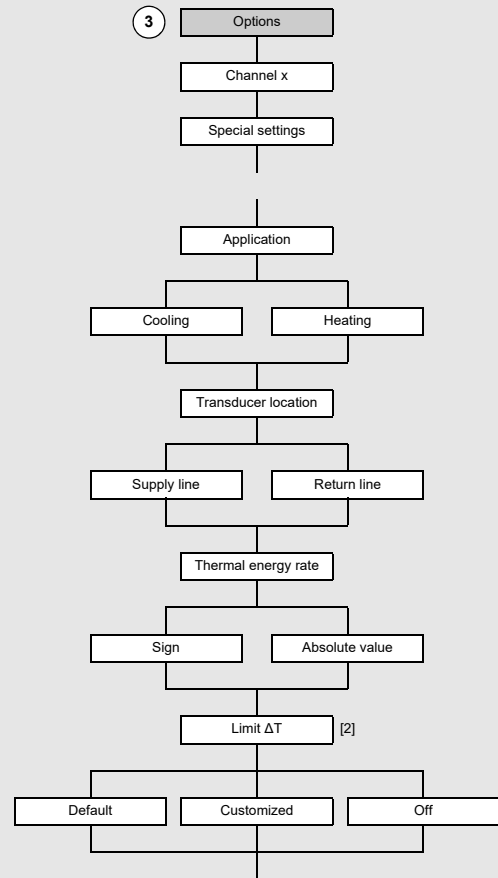
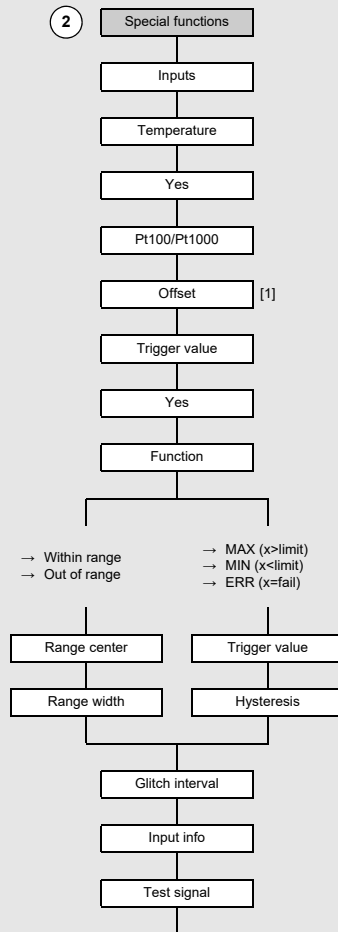
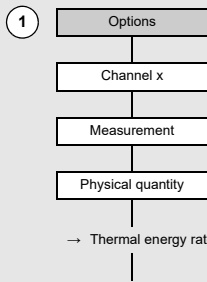
## Special settings



**Legend**

- [1] only in thermal energy rate measurement
- [2] only in thermal energy rate measurement and SuperUser mode
- [3] only in SuperUser mode
- [4] only in ExpertUser, SuperUser and SuperUser ext. mode
- [5] only if enabled in the menu item Special functions\Measurement\Measurement settings
- [6] only if FastFood is enabled in Special functions\Measurement\Measurement modes or NoiseTrek mode is supported
- [7] only if synchronized channel averaging is deactivated (FLUXUS \*722)

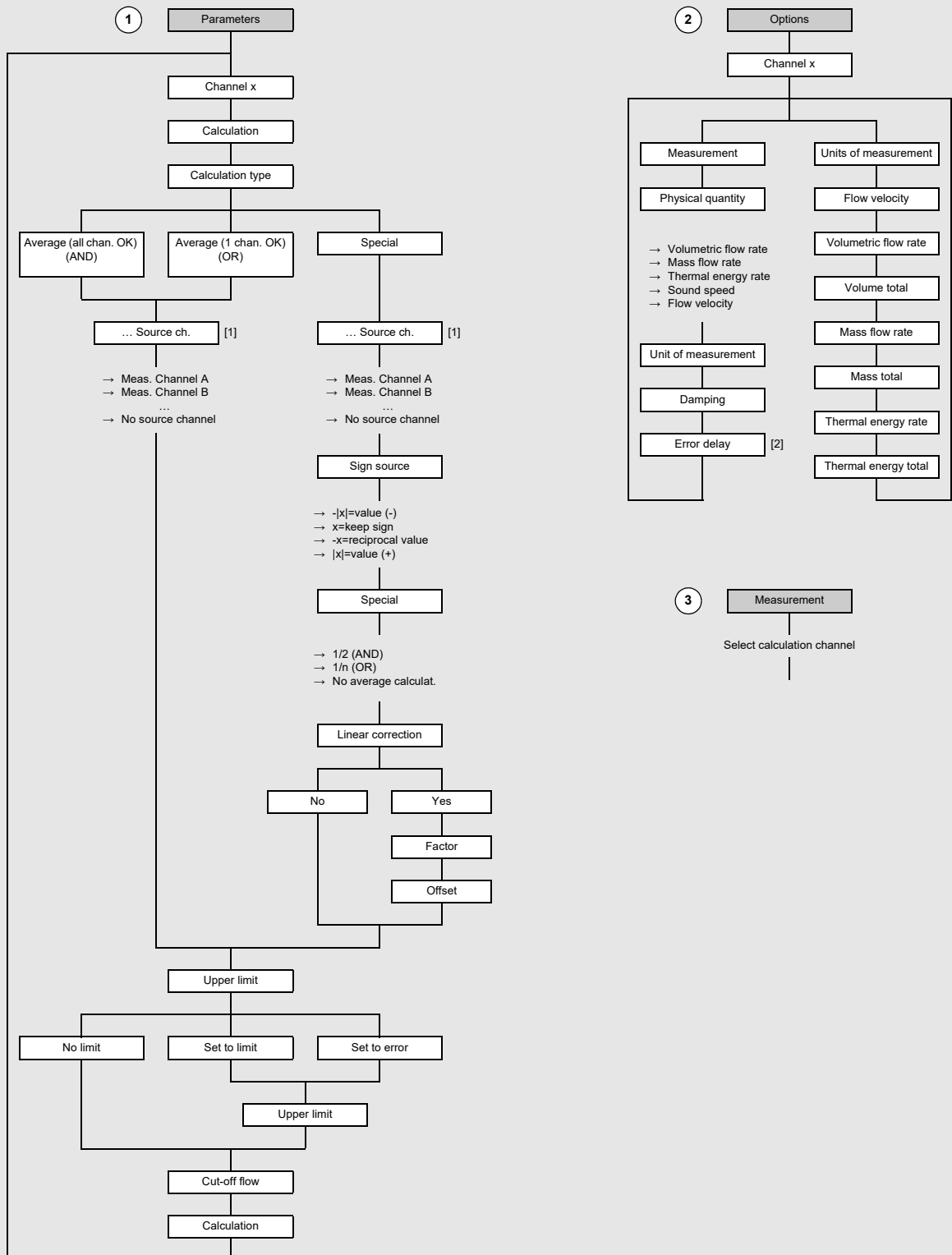
## Thermal energy rate measurement



**Legend**

- [1] only if enabled in the menu item Special functions\Dialogs/Menu
- [2] only in SuperUser mode

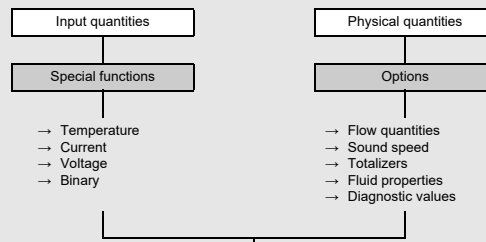
### Calculation channels



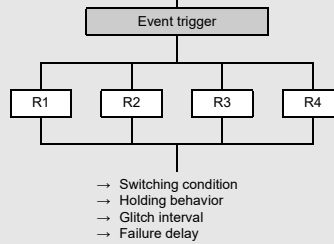
**Legend**  
 [1] n corresponds to the number of physical channels in the transmitter  
 [2] only if enabled in the menu item Special functions\Dialogs/Menus

## Results – overview

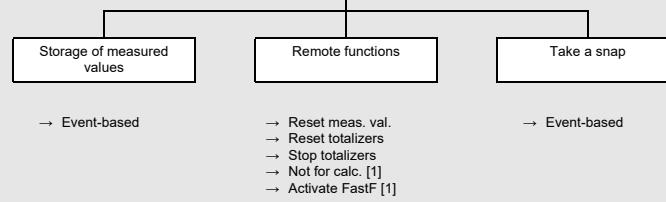
### Trigger



### Condition

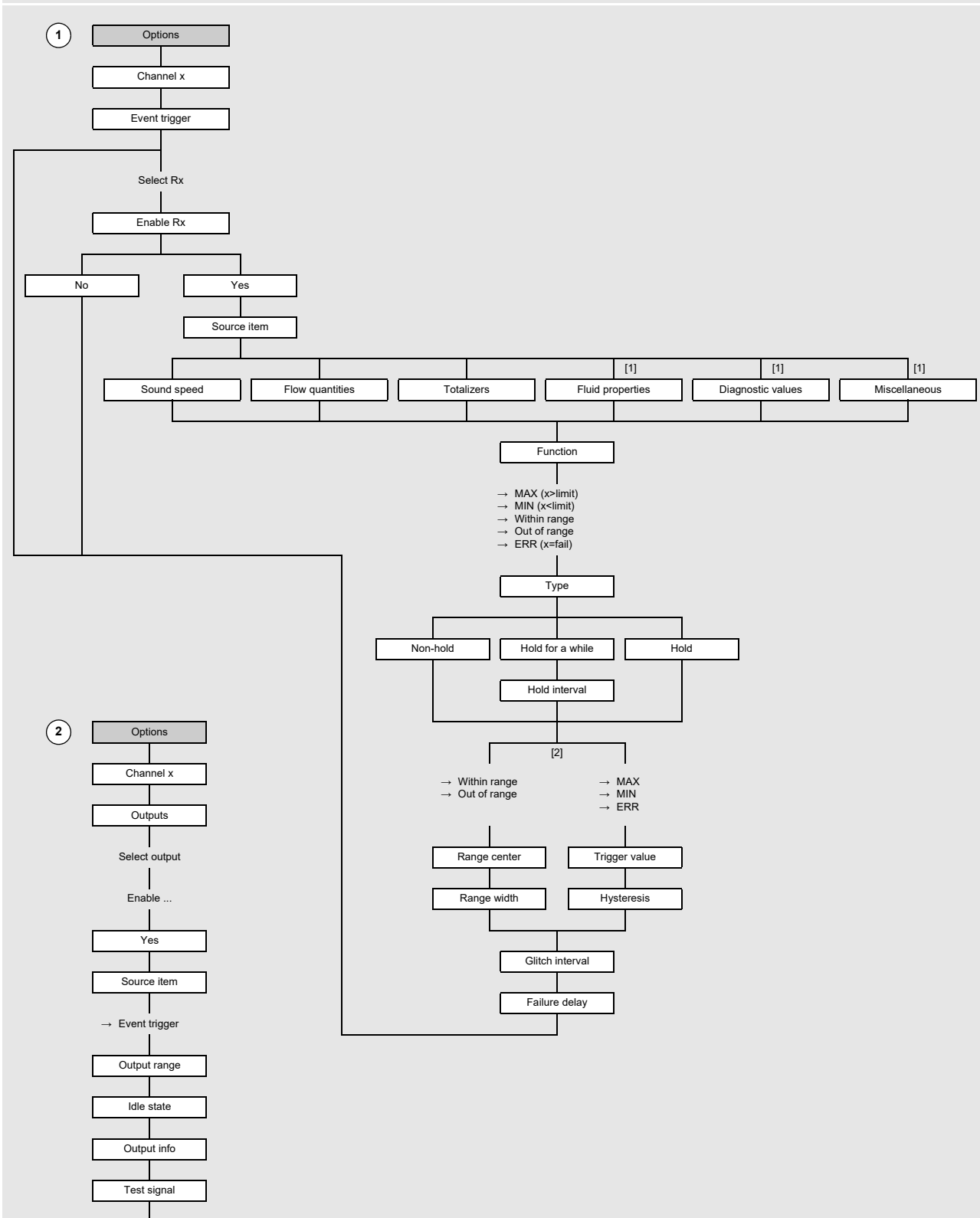


### Action



**Legend**  
[1] only for physical channels

## Definition of event triggers

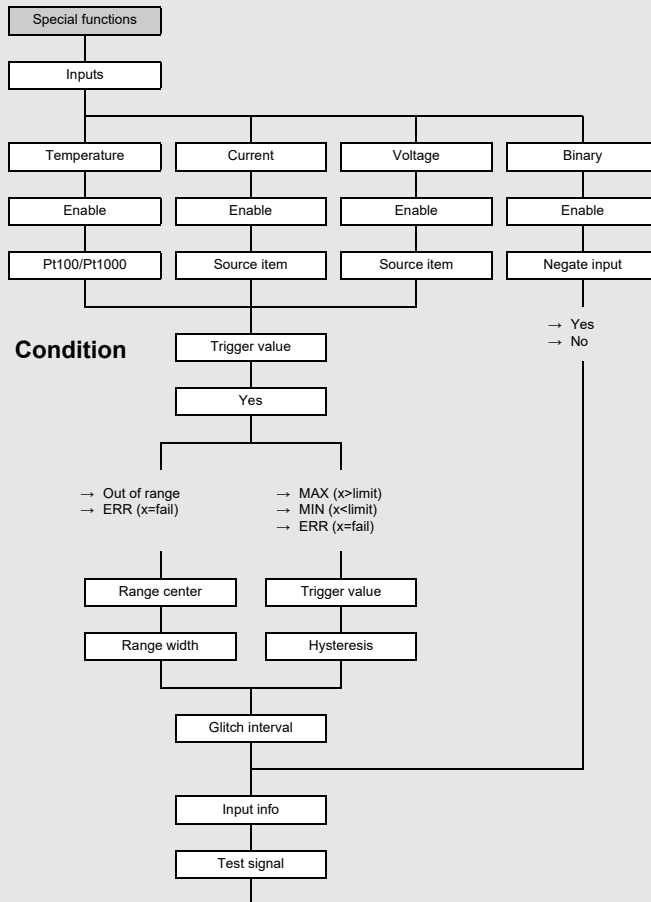


**Legend**  
 [1] not available for calculation channels  
 [2] depending on the selected function

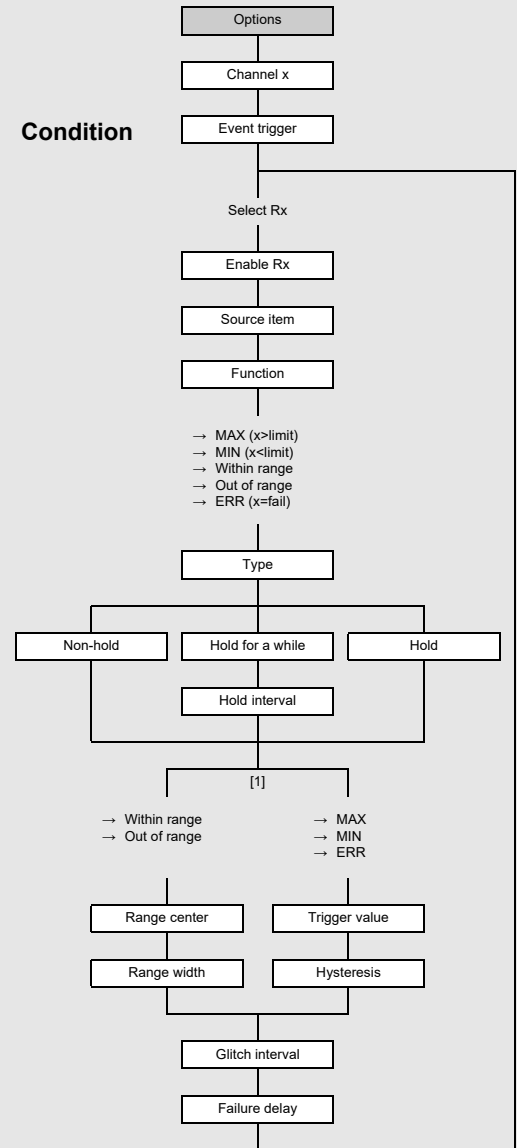


## Remote functions

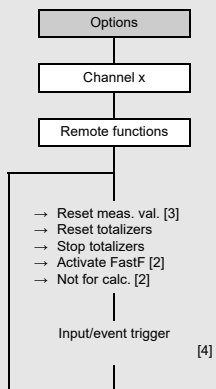
### 1 Trigger



### Condition



### 2 Action

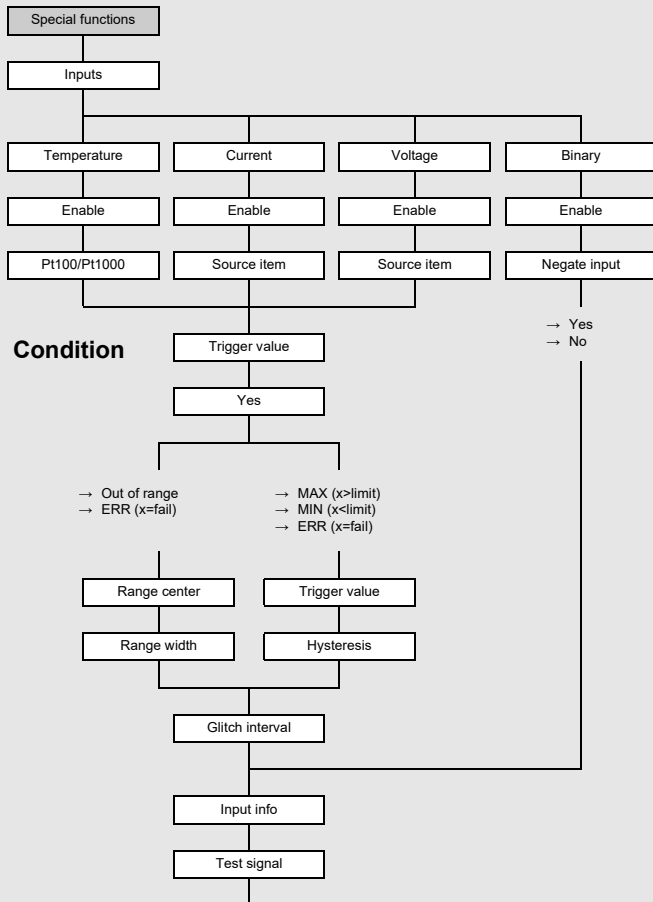


**Legend**

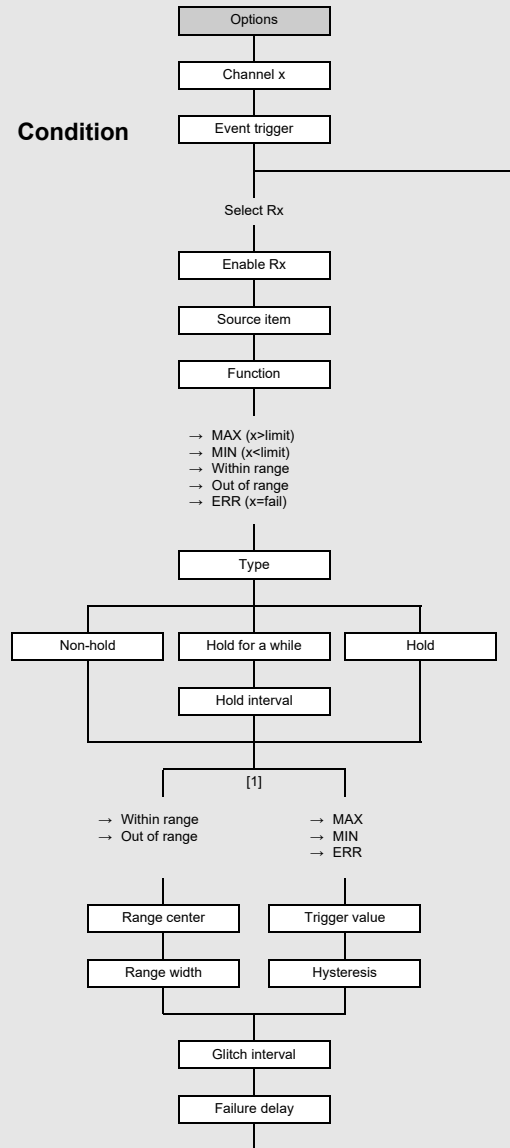
- [1] depending on the selected function
- [2] not available with calculation channels and only if FastFood mode is enabled in Special functions\Measurement\Measurement modes
- [3] only controllable via inputs
- [4] list of parameterized triggerable inputs and event triggers

## Event-based storing of measured values

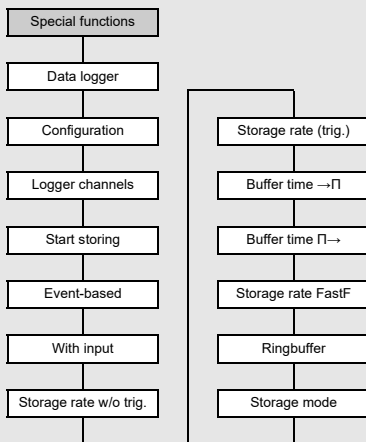
### 1 Trigger



### Condition



### 2 Action



**Legend**

[1] depending on the selected function

## Example 1

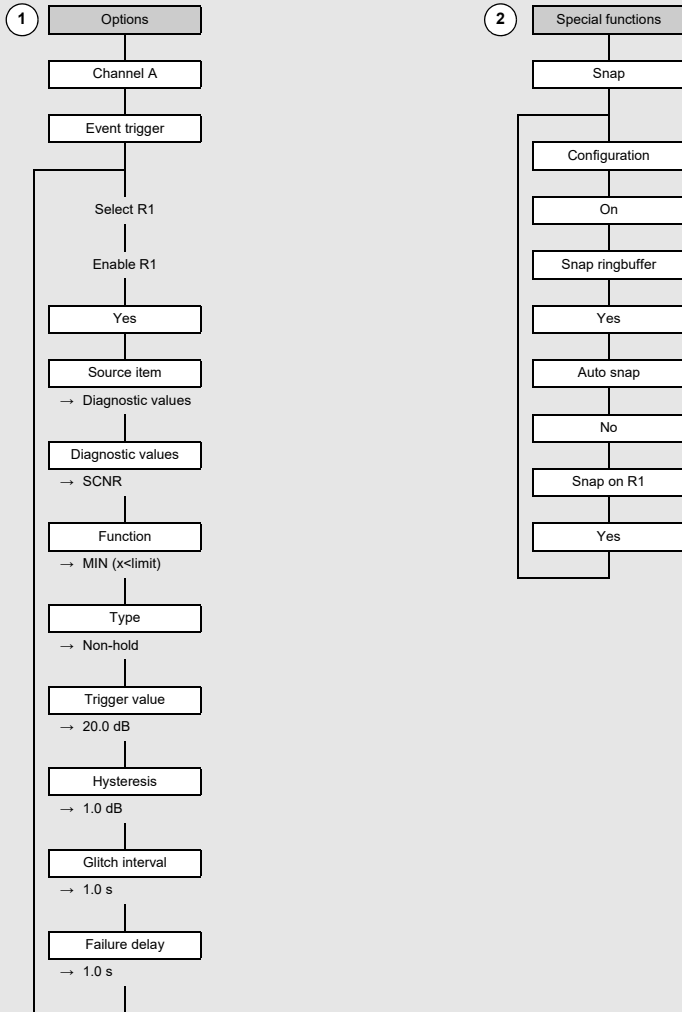
The diagnostic values are to be checked.

If the SCNR is < 20 dB, a snap has to be triggered.

Trigger: SCNR < 20 dB

Condition: R1 with SCNR < 20 dB

Action: trigger a snap





### Example 3

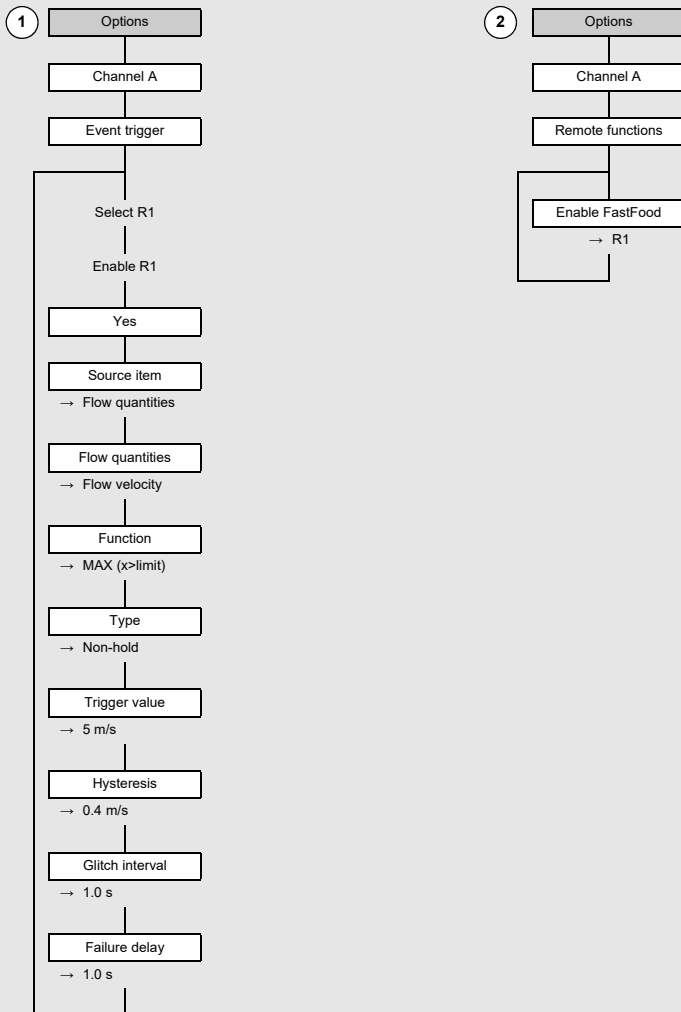
The flow velocity is measured.

If the flow velocity is  $\leq 5$  m/s, the transmitter measures in the TransitTime mode. As long as the flow velocity is  $> 5$  m/s, the transmitter has to measure in the FastFood mode.

Trigger: flow velocity  $> 5$  m/s

Condition: R1 with flow velocity  $> 5$  m/s

Action: measurement in the FastFood mode



## B Units of measurement

### Length/roughness

unit of measurement	description
mm	millimeter
in	inch

### Temperature

unit of measurement	description
°C	degree Celsius
°F	degree Fahrenheit

### Pressure

unit of measurement	description
bar (a)	bar (absolute)
bar (g)	bar (relative)
psi (a)	pound per square inch (absolute)
psi (g)	pound per square inch (relative)

### Density

unit of measurement	description
g/cm <sup>3</sup>	gram per cubic centimeter
kg/cm <sup>3</sup>	kilogram per cubic centimeter

### Sound speed

unit of measurement	description
m/s	meter per second
fps (ft/s)	foot per second

### Kinematic viscosity

unit of measurement	description
mm <sup>2</sup> /s	square millimeter per second

1 mm<sup>2</sup>/s = 1 cSt

### Flow velocity

unit of measurement	description
m/s	meter per second
cm/s	centimeter per second
in/s	inch per second
fps (ft/s)	foot per second

## Volumetric flow rate

unit of measurement	description	default volume (totalized) (1)
m <sup>3</sup> /d	cubic meter per day	m <sup>3</sup>
m <sup>3</sup> /h	cubic meter per hour	m <sup>3</sup>
m <sup>3</sup> /min	cubic meter per minute	m <sup>3</sup>
m <sup>3</sup> /s	cubic meter per second	m <sup>3</sup>
km <sup>3</sup> /h	cubic kilometer per hour	km <sup>3</sup>
ml/min	milliliter per minute	l
l/h	liter per hour	l
l/min	liter per minute	l
l/s	liter per second	l
hl/h	hectoliter per hour	hl
hl/min	hectoliter per minute	hl
hl/s	hectoliter per second	hl
Ml/d (Megalit/d)	megaliter per day	Ml
bbbl/d <sup>(4)</sup>	barrel per day	bbbl
bbbl/h <sup>(4)</sup>	barrel per hour	bbbl
bbbl/m <sup>(4)</sup>	barrel per minute	bbbl
bbbl/s <sup>(4)</sup>	barrel per second	bbbl
USgpd (US-gal/d)	gallon per day	gal
USgph (US-gal/h)	gallon per hour	gal
USgpm (US-gal/m)	gallon per minute	gal
USgps (US-gal/s)	gallon per second	gal
KGPM (US-Kgal/m)	kilogallon per minute	kgal
MGD (US-Mgal/d)	million gallons per day	Mgal
CFD	cubic foot per day	cft <sup>(2)</sup>
CFH	cubic foot per hour	cft
CFM	cubic foot per minute	cft
CFS	cubic foot per second	aft <sup>(3)</sup>
MMCFD	million cubic feet per day	MMCF

(1) selection via Options\Units of measurement

(2) cft: cubic foot

(3) aft: acre foot

(4) In the menu item Special functions\Units of measurement\Barrel type the barrel type to be displayed when setting the units of measurement for volumetric flow rate and totalized volume can be defined. If the barrel type Imperial (UK) is selected, imperial (UK) gallons instead of US gallons are used.

1 US-gal = 3.78541 l

1 UK-gal = 4.54609 l

US Barrel Oil = 42.0 US-gal ≈ 159 l

US Barrel Wine = 31.5 US-gal ≈ 119 l

US Barrel Beer = 31.0 US-gal ≈ 117 l

Imperial (UK) Barrel = 36.0 UK-gal ≈ 164 l

unit of measurement	description	default volume (totalized) (1)
MMCFH	million cubic feet per hour	MMCF
Igpd (Imp-gal/d)	gallon per day	Igal
Igph (Imp-gal/h)	gallon per hour	Igal
Igpm (Imp-gal/m)	gallon per minute	Igal
Igps (Imp-gal/s)	gallon per second	Igal
IKGM (Imp-Kgal/m)	imperial kilogallon per minute	IKG
IMGD (Imp-Mgal/d)	million imperial gallons per day	IMG

(1) selection via Options\Units of measurement

(2) cft: cubic foot

(3) aft: acre foot

(4) In the menu item Special functions\Units of measurement\Barrel type the barrel type to be displayed when setting the units of measurement for volumetric flow rate and totalized volume can be defined. If the barrel type Imperial (UK) is selected, imperial (UK) gallons instead of US gallons are used.

1 US-gal = 3.78541 l

1 UK-gal = 4.54609 l

US Barrel Oil = 42.0 US-gal ≈ 159 l

US Barrel Wine = 31.5 US-gal ≈ 119 l

US Barrel Beer = 31.0 US-gal ≈ 117 l

Imperial (UK) Barrel = 36.0 UK-gal ≈ 164 l

**Thermal energy rate**

unit of measurement	description	thermal energy (totalized) (1)
W	watt	Wh
kW	kilowatt	kWh
MW	megawatt	MWh
GW	gigawatt	GWh
kBTU/minute	kBTU per minute	kBT
kBTU/hour	kBTU per hour	kBT
MBTU/hour	MBTU per hour	MBT
MBTU/day	MBTU per day	MBT
TON (TH)	TON, totals in TONhours	TH
TON (TD)	TON, totals in TONdays	TD
kTON (kTH)	kTON, totals in kTONhours	kTH
kTON (kTD)	kTON, totals in kTONdays	kTD

BTU: British thermal unit

1 W = 1 J/s = (1/1055.05585262) BTU/s

TON: ton of refrigeration

1 W = 1 J/s = (1/3516.852842) TON

1 TON = 200 BTU/min

(1) selection via Options\Units of measurement



**Mass flow rate**

unit of measurement	description
t/h	ton per hour
t/d	ton per day
kg/h	kilogram per hour
kg/min	kilogram per minute
kg/s	kilogram per second
g/s	gram per second
lb/d	pound per day
lb/h	pound per hour
lb/m	pound per minute
lb/s	pound per second
klb/h	kilopound per hour
klb/m	kilopound per minute

mass (totalized)
t
t
kg
kg
kg
g
lb
lb
lb
lb
klb
klb

1 lb = 453.59237 g  
1 t = 1000 kg

## C Reference

The following tables provide assistance for the user. The accuracy of the data depends on the composition, temperature and processing of the material. FLEXIM does not assume liability for any inaccuracies.

### C.1 Sound speed of selected pipe and lining materials at 20 °C

The values of some of these materials are stored in the internal database of the transmitter. Column  $c_{\text{flow}}$  shows the type of sound wave (longitudinal or transversal) used for the flow measurement.

material (display)	explanation	$c_{\text{trans}}$ [m/s]	$c_{\text{long}}$ [m/s]	$c_{\text{flow}}$
Carbon steel	steel, normal	3230	5930	trans
Stainless steel	steel, stainless	3100	5790	trans
DUPLEX	duplex stainless steel	3272	5720	trans
Ductile iron	ductile iron	2650	-	trans
Asbestos cement	asbestos cement	2200	-	trans
Titanium	titanium	3067	5955	trans
Copper	copper	2260	4700	trans
Aluminum	aluminum	3100	6300	trans
Brass	brass	2100	4300	trans
Plastic	plastic	1120	2000	long
GRP	glass reinforced plastic	-	2650	long
PVC	polyvinyl chloride	-	2395	long
PE	polyethylene	540	1950	long
PP	polypropylene	2600	2550	trans
Bitumen	bitumen	2500	-	trans
Acrylic glass	acrylic glass	1250	2730	long
Lead	lead	700	2200	long
Cu-Ni-Fe	copper-nickel-iron alloy	2510	4900	trans
Cast iron	gray cast iron	2200	4600	trans
Rubber	rubber	1900	2400	trans
Glass	glass	3400	5600	trans
PFA	perfluoralkoxy	500	1185	long
PVDF	polyvinylidene fluorid	760	2050	long
Sintimid	Sintimid	-	2472	long
Teka PEEK	Teka PEEK	-	2534	long
Tekason	Tekason	-	2230	long

The sound speed depends on the composition and processing of the material. The sound speed of alloys and cast materials fluctuates strongly. The values only serve as an orientation.

## C.2 Typical roughness values of pipes

The values are based on experience and measurements.

material	absolute roughness [mm]
drawn pipes of non-ferrous metal, glass, plastics and light metal	0...0.0015
drawn steel pipes	0.01...0.05
fine-planed, polished surface	max. 0.01
planed surface	0.01...0.04
rough-planed surface	0.05...0.1
welded steel pipes, new	0.05...0.1
after long use, cleaned	0.15...0.2
moderately rusted, slightly encrusted	max. 0.4
heavily encrusted	max. 3
cast iron pipes:	
bitumen lining	> 0.12
new, without lining	0.25...1
rusted	1...1.5
encrusted	1.5...3

### C.3 Typical properties of selected fluids at 20 °C

#### C.3.1 Mixtures with non-changing composition

fluid	explanation	sound speed [m/s]	density [g/cm <sup>3</sup> ]	kinematic viscosity [mm <sup>2</sup> /s]	range of application [°C]	WMM <sup>(1)</sup>
Water	liquid water	1482	0.999	1	0...350	x
Propane	liquefied under pressure	755	500	0.2	-180...+97	
Butane	liquefied under pressure, coolant R-600	929	577	0.3	-135...+152	x
Ammonia	liquefied under pressure, coolant R-717	1373	610	0.2	-78...+132	x
Methanol		1119	792	0.7	-95...+240	
Ethanol		1158	789	1.5	-110...+241	
Acetone		1187	791	0.4	-90...+235	
R134a FKW	coolant FC	521	1240	0.2	-100...+100	x
R407C FKW	coolant FC	494	1158	0.1	-20...+81	x
R410A FKW	coolant FC	457	1085	0.1	-130...+71	x
R22 FCKW	coolant FC	557	1213	0.1	-150...+90	x
BP Transcal LT	thermal oil	1365	876	20	-20...+260	x
BP Transcal N	thermal oil	1365	876	94	0...320	x
Shell Thermia B	thermal oil	1365	863	89	0...310	x
Mobiltherm 594	thermal oil	1365	873	7.5	-44...+260	x
Mobiltherm 603	thermal oil	1365	859	55	0...320	x
Gasoline	hydrocarbon with 58 °API	1252	741	1.1	-50...+450	
Diesel	hydrocarbon with 38 °API	1380	831	2.2	-50...+450	
Jet A1	hydrocarbon with 44 °API	1358	821	1.7	-50...+450	

<sup>(1)</sup> thermal energy rate coefficient included in the fluid data set

**C.3.2 Mixtures with changing composition**

fluid	explanation	parameter-ization <sup>(1)</sup>	sound speed [m/s]	density [g/cm <sup>3</sup> ]	kinematic viscosity [mm <sup>2</sup> /s]	range of application	WMM <sup>(2)</sup>
Glycol/H <sub>2</sub> O	ethylene glycol	proportion of glycol	1482...1710	999...1132	1...23	-30...+150 °C 0...100 %	x
Petroleum	hydrocarbon	API gravity	530...1800	440...1130	1...> 400	-50...+450 °C -10...200 °API	
Lubricant	hydrocarbon-based lubricant, kinematic viscosity at 40 °C	viscosity grade (VG)	1433...1485	871...923	1...> 400	-40...+300 °C 1...1500 VG	
Sea water		salinity (S in g/kg)	1482...1840	999...1230	1...1.3	-30...+150 °C 0...300 g/kg	x
Sulfuric acid	mixture of sulfuric acid and water	proportion of sulfuric acid	1280...1560	999...1907	1...12	-20...+250 °C 0...100 %	
Hydrochloric acid	mixture of hydrochloric acid and water	proportion of hydrochloric acid	1482...1527	999...1256	1...1.5	-20...+150 °C 0...50 %	
Nitric acid	mixture of nitric acid and water	proportion of nitric acid	1286...1590	999...1554	1...2.4	-20...+150 °C 0...100 %	
Hydrofluoric acid	mixture of hydrofluoric acid and water	proportion of hydrofluoric acid	804...1482	999...1195	0.5...1	-20...+105 °C 0...100 %	
Soda lye	mixture of soda lye and water	proportion of soda lye	1482...2563	999...1666	1...265	-10...+200 °C 0...65 %	

<sup>(1)</sup> in the program branch `Parameters`

<sup>(2)</sup> thermal energy rate coefficient included in the fluid data set

### C.4 Properties of water at 1 bar and at saturation pressure

fluid temperature [°C]	fluid pressure [bar]	sound speed [m/s]	density [kg/m <sup>3</sup> ]	specific heat capacity <sup>(1)</sup> [kJ/kg/K <sup>-1</sup> ]
0.1	1.013	1402.9	999.8	4.219
10	1.013	1447.3	999.7	4.195
20	1.013	1482.3	998.2	4.184
30	1.013	1509.2	995.6	4.180
40	1.013	1528.9	992.2	4.179
50	1.013	1542.6	988.0	4.181
60	1.013	1551.0	983.2	4.185
70	1.013	1554.7	977.8	4.190
80	1.013	1554.4	971.8	4.197
90	1.013	1550.5	965.3	4.205
100	1.013	1543.2	958.3	4.216
120	1.985	1519.9	943.1	4.244
140	3.615	1486.2	926.1	4.283
160	6.182	1443.2	907.4	4.335
180	10.03	1391.7	887.0	4.405
200	15.55	1332.1	864.7	4.496
220	23.20	1264.5	840.2	4.615
240	33.47	1189.0	813.4	4.772
260	46.92	1105.3	783.6	4.986
280	64.17	1012.6	750.3	5.289
300	85.88	909.40	712.1	5.750
320	112.8	793.16	667.1	6.537
340	146.0	658.27	610.7	8.208
360	186.7	479.74	527.6	15.00
373.946	220.640	72.356	322.0	∞

<sup>(1)</sup> at constant pressure

## D Conformity declarations

For EU declaration of conformity according to ATEX directive, see document SIFLUXUS.





## EU declaration of conformity according to low voltage directive

**FLEXIM Flexible Industriemesstechnik GmbH**

Boxberger Straße 4  
12681 Berlin  
Germany

declares as manufacturer under its sole responsibility that the ultrasonic flowmeter(s)

**FLUXUS a72b\*\*-NN0\*c, PIOX S72b\*\*-NN0\*c**

**a = F, G, H**

**b = 1, 2**

**c = A, S**

complies/comply with the relevant EU regulations and directives, including any amendments valid at the time this declaration was signed. This declaration of conformity is based on the following harmonized EU standards:

**EU directive 2014/35/EU (low voltage directive)** relating to the making available on the market of electrical equipment designed for use within certain voltage limits

EN 61010-1:2010 Safety requirements for electrical equipment for measurement, control, and laboratory use  
Part 1: General requirements

EN 61010-2-030:2010 Safety requirements for electrical equipment for measurement, control, and laboratory use  
Part 2-030: Particular requirements for testing and measuring circuits

**EU directive 2014/30/EU (EMC directive)** relating to electromagnetic compatibility

EN 61326-1:2013 Electrical equipment for measurement, control, and laboratory use – EMC requirements  
Part 1: General requirements

EN 55011:2009/A1:2010 Industrial, scientific and medical equipment – Radio-frequency disturbance characteristics –  
Limits and methods of measurement

**EU directive 2011/65/EU (RoHS directive)** on the restriction of the use of certain hazardous substances in electrical and electronic equipment

EN 50581:2012 Technical documentation for the assessment of electrical and electronic products with  
respect to the restriction of hazardous substances

FLEXIM GmbH

Signed for and on behalf of

Berlin, 2020-11-30

Place and date



Jens Hilpert  
Managing Director